

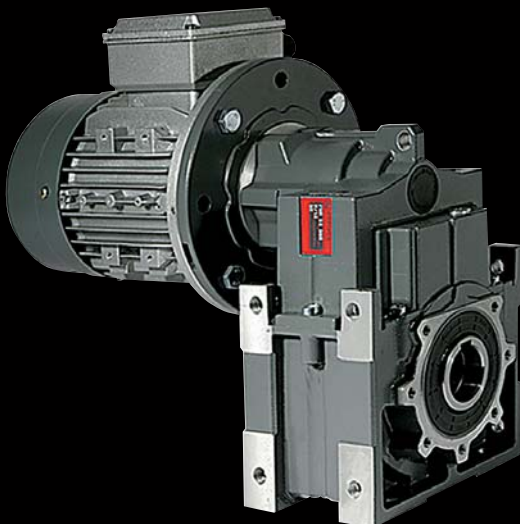

# VARVEL®

MOTION CONTROL SINCE 1955

technology made in Italy



IT  
EN  
DE

# RN



## Tecnologia Made in Italy

IT

Dal 1955 il Gruppo Varvel progetta e realizza riduttori e variatori per applicazioni fisse di piccola e media potenza. Partner affidabile nella produzione e vendita di organi di trasmissione grazie a un elevato livello di servizio, offre anche soluzioni personalizzate operando nel rispetto dei valori dell'impresa socialmente responsabile. Modularità e flessibilità guidano la progettazione dei prodotti Varvel nella realizzazione di kit comuni a tutte le famiglie di riduttori, agevolando così l'attività di distributori e rivenditori che possono configurare in pochi minuti il prodotto richiesto dal singolo cliente.

## Technology Made in Italy

EN

Since 1955 the Varvel Group has been making gearboxes and variators for light industry applications. Reliable partner in power transmission equipment offers also customized solutions always according to a socially responsible company values. Modularity and flexibility lead Varvel products by a unique kit form, common to all gearbox series. This feature allows distributors an easier job to set up required products in few minutes.

## Technologie Made in Italy

DE

Seit 1955 plant und stellt die Varvel-Gruppe Getriebe und Verstellgetriebe für feste Kleinleistungsanwendungen her. Dank dem hohen Dienstniveau ist Varvel ein zuverlässiger Partner für Herstellung und Verkauf von Getriebewerkteilen und bietet maßgeschneiderte Lösungen an, in Verbindung mit sozialverträglicher Handlungsweise. Modularität und Flexibilität sind Kennzeichen für Varvel-Produkte. Die Firma produziert Teile, die sich für alle Getriebetypen eignen. Verteiler und Verkäufer können somit den Kundenanforderungen gerecht werden.



- UNI EN ISO 9001:2008
- UNI EN ISO 14001:2004
- BS OHSAS 18001:2007



- EC DIRECTIVE 2014/34/EU (ATEX)



# RN

## RIDUTTORI AD ASSI PARALLELI

- due e tre coppie di ingranaggi



## PARALLEL SHAFT GEARBOXES

- two and three gear trains

## FLACHGETRIEBE

- Zwei- u. Dreistufige



INDICE 	CONTENTS 	INDEX 
Descrizione ..... 2-4	Description..... 2-4	Beschreibung.....2-4
Simboli ..... 5	Symbols.....5	Abkürzungen .....5
Modularità ..... 6-7	Modular system ..... 6-7	Modularsystem ..... 6-7
Giunto elastico „G“ ..... 8	Flexible coupling „G“ .....8	Kupplung „G“ ..... 8
Selezione Giunto elastico..... 9	Flexible coupling selection .....9	Kupplungsauswahl.....9
Flange IEC & Giunto ..... 10	IEC Flanges & coupling.....10	IEC-Flansch u. Kupplung ..... 10
Flange NEMA & Giunto ..... 11	NEMA Flanges & coupling .....11	NEMA-Flansch u. Kupplung..... 11
Designazione Riduttore e Motore ... 12	Gearbox & Motor designation.....12	Getriebe- u. Motorbezeichnungen ... 12
Catalogo elettronico VARsize ..... 13	VARsize electronic catalogue.....13	Elektronischer Katalog VARsize..... 13
Posizioni di montaggio ..... 14	Mounting positions .....14	Einbaulage.....14
Fattori di servizio ..... 15-16	Service factors .....15-16	Betriebsfaktoren..... 15-16
Carichi esterni ..... 17	External loads .....17	Außere Kräfte ..... 17
<b>Tabelle di Selezione</b>	<b>Selection tables</b>	<b>Auswahltabelle</b>
Versioni..... 18	Versions.....18	Ausführungen ..... 18
Potenza termica ..... 19	Thermal power.....19	Thermische Nennleistung ..... 19
FRN - SRN - RN ..... 20-25	FRN - SRN - RN .....20-25	FRN -SRN - RN .....20-25
MRN ..... 26-54	MRN .....26-54	MRN .....26-54
<b>Dimensioni</b>	<b>Dimensions</b>	<b>Abmessungen</b>
Motori IEC..... 55	IEC Motors.....55	IEC-Motoren ..... 55
RN 12-13 ..... 56-59	RN 12-13 .....56-59	RN 12-13 .....56-59
RN 22-23 ..... 60-63	RN 22-23 .....60-63	RN 22-23 .....60-63
RN 32-33 ..... 64-67	RN 32-33 .....64-67	RN 32-33 .....64-67
RN 42.43..... 68-71	RN 42.43 .....68-71	RN 42.43 .....68-71
RN 52-53 ..... 72-75	RN 52-53 .....72-75	RN 52-53 .....72-75
RN 62-63 ..... 76-79	RN 62-63 .....76-79	RN 62-63 .....76-79
<b>Informazioni generali</b>	<b>General information</b>	<b>Allgemeine Informationen</b>
Alberi cavi AC ..... 80	AC Hollow shafts .....80	AC Hohlwellen .....80
Alberi cavi ACC..... 81	ACC Hollow shafts .....81	ACC Hohlwellen.....81
Alberi cavi ACS ..... 82	ACS Hollow shafts .....82	ACS Hohlwellen.....82
Posizione accessori ..... 83	Accessory position .....83	Zubehörlage .....83
Rotazione e Parti componenti ..... 84	Rotation and Component parts .....84	Drehrichtung u. Bauelemente .....84
Standard motori elettrici ..... 85	Electric motor standards .....85	E-Motoren Standards.....85
Riepilogo ATEX..... 86-87	ATEX summing-up.....86-87	ATEX Zusammenfassung .....86-87
Uso e Manutenzione ..... 88	Operation and Maintenance .....88	Betriebs u. Wartungsanweisung.....88

## RN Riduttori - Gearboxes - Getriebe

### Descrizione - Description - Beschreibung



La serie dei riduttori RN è concepita secondo le norme di progettazione ISO con l'ausilio di analisi strutturale per verifica della deformata e dello stress.

La robusta struttura non subisce deformazioni significative sotto effetto della coppia di funzionamento e dei carichi esterni con positivi risultati sulle superfici di tenuta.

I riduttori delle serie RN sono costruiti in alluminio pressofuso per le prime 3 grandezze ed in ghisa per le rimanenti. La versione pendolare permette la conversione in forma flangiata B5 applicando semplicemente una delle diverse flange di uscita disponibili.

Diverse dimensioni e tipi di alberi di uscita (cavo con chiavetta, cavo con calettatore e pieno con una o due estremità) sono disponibili per la più ampia possibilità di applicazioni.

La serie RN è prevista in 6 grandezze, 30 rapporti per due e tre coppie di riduzione per ognun tipo di riduttore e momenti torcenti fra 160 e 3400 Nm.

La serie dei riduttori RN è costituita da riduttori ad assi paralleli con albero di uscita cavo, in esecuzione a due e tre coppie di riduzione.

#### Direttiva ATEX

I riduttori VARVEL-ATEX, fornibili su richiesta, sono progettati e costruiti in accordo alla Direttiva 94/9/CE "ATEX" e sono pertanto idonei alla installazione in atmosfere potenzialmente esplosive:

- Zone di Gruppo II,
- Categoria 2 (o 3),
- Pericolo di esplosione in presenza di Gas (Zona 1 o 2),
- Pericolo di esplosione in presenza di Polveri combustibili (Zona 21 o 22).

Vedi informazioni dettagliate alle pagine 86 e 87.

La serie VARVEL-ATEX viene identificata mediante la marcatura supplementare:

The gearboxes, series RN are designed according to latest ISO engineering specifications with the help of computer aided structural analysis for displacement and stress field.

The monolithic framework does not deflect under the effect of torque and external loads with effective results on sealing surfaces.

The gearboxes of series RN are manufactured of pressure die cast for the first 3 sizes and of cast iron for the others.

The shaft mount version allows the flange mount B5 conversion by simply fitting one of the many output flanges available.

Various dimensions and types of output shafts (hollow with through keyway, hollow with shrink disk and solid with single or double end) are available for the majority of applications.

The series RN is made in 6 sizes, 30 reduction ratios and output torques between 160 and 3400 Nm.

The gearbox series RN consists of parallel shaft gearboxes with hollow output shaft, and two- and three-stage execution.

#### Directive ATEX

The gearboxes VARVEL-ATEX, supplied on demand, are designed and manufactured according to Directive 94/9/CE "ATEX" and therefore, they are qualified for installation in potentially explosive atmospheres:

- Zones of Group II,
- Category 2 (or 3),
- Explosion hazard with gas presence (Zone 1 or 2),
- Explosion hazard with combustible dust presence (Zone 21 or 22).

See detailed information at pages 86, 87.

The units VARVEL-ATEX are identified by the additional marking:

Die Getriebe der Baureihe RN nach den ISO Normen konstruiert und anhand von Analysen auf Deformation und Kräfteeinwirkung nachgerechnet sind mit einem gemeinsamen Gehäuse hergestellt und haben somit die gleichen Befestigungsanschlüsse.

Die Gehäusestruktur wird von den Betriebsdrehmomenten und durch außen am Getriebe wirkende Kräfte nahezu nicht beeinflusst, was sich positiv auf die Lebensdauer der Wellendichtungen auswirkt.

Die ersten drei Größen der Getriebe der Baureihe RN sind aus Aluminiumdruckguss, die restlichen aus Grauguß.

Die Aufsteckausführung kann in Flanschausführung B5 nachgerüstet werden mittels eines der vielen zur Auswahl stehenden Ausgangsflansche.

Eine breite Auswahl an Wellenabmessungen am Ausgang (Hohlwelle mit Nut, Hohlwelle mit Schrumpfscheibe oder Vollwelle ein- oder beidseitig) ist verfügbar.

Die Serie RN ist für 6 Baugrößen lieferbar, mit 30 Untersetzungen, zwei oder dreistufig und Ausgangsdrehmomenten zwischen 160 und 3400 Nm.

Die Getriebe der Baureihe RN erlaubt aus Flachgetriebe mit Hohlwelle, zwei und drei stufige Ausführung.

#### ATEX Richtlinien

Die Getriebe Varvel-ATEX, ausschließlich auf Anfrage geliefert, sind entsprechend den ATEX-Richtlinien 94/9/ EG "ATEX" konstruiert und hergestellt und somit zugelassen für die Installation in potentiell zündfähigen Atmosphäre:

- Gefahrenbereiche der Gruppe II
- Kategorie 2 (oder 3)
- Explosionsgefährdeter Bereich mit Gase (Gefahrenbereiche 1 oder 2)
- Explosionsgefährdeter Bereich mit zündfähigen Stäube (Gefahrenbereiche 21 oder 22).

Ausführliche Informationen finden Sie auf den Seiten 86 und 87.

Die Varvel-ATEX Produkte sind mit folgenden zusätzlichen Stempelung versehen.

# Getriebe - Gearboxes - Riduttori RN

Beschreibung - Description - Descrizione



<b>Serie RN</b> <b>Riduttori ad assi paralleli</b>	<b>Series RN</b> <b>Parallel shaft gearboxes</b>	<b>Baureihe RN</b> <b>Flachgetriebe mit Hohlwelle</b>
<p><b>Carcassa multiuso</b> Montaggio con Piedi e Piedi/Flangia Unica carcassa per 2 o 3 coppie</p> <p><b>Carcasse e Coperchi</b> Alluminio in pressofusione (3 grandezze) Ghisa (3 grandezze)</p> <p><b>Entrata</b> Flange IEC e NEMA con giunto elastico o foro con chiavetta</p> <p><b>Ingranaggi</b> Acciaio legato Cementato e temprato Profilo dei denti rettificato/sbarbato</p> <p><b>Paraoli</b> Nitrile Butadiene Rubber - NBR come standard; Viton e Silicone a richiesta.</p> <p><b>Cuscinetti</b> A sfera o a rulli secondo le grandezze e caratteristiche tecniche.</p> <p><b>Uscita</b> Alberi metrici; in pollici a richiesta.</p> <p><b>Lubrificazione</b> Olio Sintetico di lunga durata. Gradazione ISO VG 320. Senza tappi. Riempimento in fabbrica.</p>	<p><b>Multipurpose Housing</b> Foot &amp; Foot/Flange mountings One housing for 2- &amp; 3-stages</p> <p><b>Housing &amp; Covers</b> Aluminium die cast (3 sizes) Grey cast iron (3 sizes).</p> <p><b>Input</b> IEC and NEMA motor adapters with universal flexible coupling, or bore and keyway.</p> <p><b>Gearing</b> Alloy steel Case hardened Profile ground or shaved.</p> <p><b>Oil seals</b> NBR - Nitrile Butadiene Rubber as standard Viton and Silicone on request.</p> <p><b>Bearings</b> Ball or roller types according to sizes and technical require- ments.</p> <p><b>Output</b> Solid shafts, metric and imperial</p> <p><b>Lubrication</b> Synthetic long-life oil Grade ISO VG 320 No oil/vent plugs In-house filling</p>	<p><b>Mehrzweckgehäuse</b> Montage mit Fuß und Fuß/Flansch einheitliches Gehäuse für 2-3 Stufen</p> <p><b>Gehäuse u. Deckeln</b> Aluminium-Druckguß (3 Großen) Grauguß (3 Großen)</p> <p><b>Eingang</b> Flansche in IEC- u. NEMA-Ausführung mit elastischer Kupplung oder Hochwelle mit Paßfederverbindung</p> <p><b>Verzahnungen</b> legierter Stahl Vergütet u. gehärtet geschliffen / rasiert Zahnprofil</p> <p><b>Wellendichtringe</b> Nitrilbutadien Gummi NBR als Standard; Viton u. Silikon auf Anfrage</p> <p><b>Lager</b> Kegel- oder Rollenlager, nach die Größen u. technische Spezifikationen</p> <p><b>Ausgang</b> metrische Wellen, Zollmaß auf Anfrage</p> <p><b>Schmierung</b> Langzeitschmiermittelfüllung: ISO VG 320. ohne zusätzliche Verschlusschrauben Füllung im Werk</p>



## RN Riduttori - Gearboxes - Getriebe

### Descrizione - Description - Beschreibung

	<b>SPECIFICHE GENERALI</b>	<b>GENERAL SPECIFICATIONS</b>	<b>ALLGEMEINE EIGENSCHAFTEN</b>
Gamma Range Bereich	6 grandezze 40 rapporti in 2 e 3 coppie 3400 Nm coppia uscita max.	6 sizes 40 ratios in 2 and 3 stages 3400 Nm max. output torque	6 Baugrößen 40 Übersetzungen 2- u. 3- stufig 3400 Nm max. Abtriebsmoment
Dimensionamento Sizing Auslegung	Secondo ISO6336 / DIN3990. Vita media 10.000 ore con fattore di servizio SF1	According to ISO6336/DIN3990. 10,000 hrs average lifetime with service factor SF1	Laut ISO6336/DIN3990. 10.000 durchschnittlich-Stunden Lebensdauer für Verzahnung und Lagerung bei einem Betriebsfaktor SF1
Carcassa, Coperchi Housing, Covers Gehäuse, Flansche	Pressofusione in alluminio fino taglia 3 e ghisa dalla taglia 4	Pressure die cast aluminium up to size 3 and cast iron from size 4	Aluminium-Druckguss bis Größe 3 und Grauguss ab Größe 4
Entrata con giunto G Coupling G input Kupplungseingang G	Pressofusione in alluminio per taglie G3, G5, G6 e acciaio dalla taglia G8	Pressure die cast aluminium for sizes G3, G5, G6 and alloyed steel from size G8	Aluminium-Druckguss für Größen G3, G5, G6 und Stahl ab Größe G8
Parti dentate Toothed parts Verzahnung	Acciaio cmt / tmp Evolvente rettificato o sbarbato Coppie coniche rodiate	Steel case hardened Tooth profile ground or shaved Run-in bevel gears	Stahl einsatzgehärtet Zahnprofil geschliffen / rasiert Kegelräder eingelaufen
Alberi uscita cavi Hollow output shafts Abtriebshohlwelle	Ghisa sferoidale	Ductile cast iron	Duktilen Gusseisen
Alberi & Linguette Shafts & Keys Wellen	Acciaio Tolleranze: Alberi h6, Fori E8 Linguette secondo DIN6885 B1	Steel Tolerances: Shafts h6, Bores E8 Keys according to DIN6885 B1	Stahl Toleranzen: Wellen h6, Bohrungen E8 Passfedern nach DIN6885 B1
Cuscinetti Bearings Lagerung	Sfere o rulli secondo grandezza e specifiche tecniche	Ball- or roller-types according to sizes and technical requirements	Kugel- oder Rollenlager entsprechend den technischen Vorschriften
Paraolio Oil seals Dichtungen	Tipo NBR - Nitril-Butadiene Rubber con secondo labbro parapolvere secondo DIN 3760 Tipo FKM - Fluoro-elastomero Viton a richiesta	Type NBR - Nitril-Butadiene Rubber with additional anti-dust lip according to DIN 3760 Type FKM - Fluor elastomer Viton on demand	Typ NBR - Nitril-Butadien Rubber mit zusätzlicher Staublippe entsprechend DIN 3760 Typ FKM - Fluorelaste Viton auf Anfrage
Lubrificante Lubricant Schmierung	Olio sintetico a lunga durata Gradazione ISO VG 320	Synthetic long-life oil Grade ISO VG 320	Synthetisches Getriebeöl ISO VG 320 als Langzeit-Füllung
Verniciatura Painting Gehäuselackierung	Alluminio naturale fino taglia 3 e vernice a polveri epossidiche colore standard RAL 7012 dalla taglia 4	Aluminium until size 3 and Epoxy powder paint Standard colour RAL 7012 from size 4	Aluminium bis Größe 3 und Epoxypulverfarbe Standard-farbtone RAL 7012 ab Größe 4
ATEX	A richiesta ⊕ II 2 GD ck IP66 ⚡ T <sub>max</sub> =135 °C	On demand ⊕ II 2 GD ck IP66 ⚡ T <sub>max</sub> =135 °C	Auf Anfrage ⊕ II 2 GD ck IP66 ⚡ T <sub>max</sub> =135 °C

# Getriebe - Gearboxes - Riduttori RN

## Abkürzungen - Symbols - Simboli

Simbolo Symbol Abkürzung	Descrizione	Description	Beschreibung
D [mm]	Diametro primitivo dell'elemento di trasmissione $k_{(t)}$	PCD of transmission element $k_{(t)}$	Wirkkreisdurchmesser des Übertragungselementes $k_{(t)}$
$F_r$ [N]	Carico radiale dell'applicazione	Application radial load	Radialkraft der Anwendung
$F_{r1}$ [N]	Carico radiale di catalogo (entrata)	Catalogue radial load (input)	Radialkraft aus dem Katalog (Eingang)
$F_{r2}$ [N]	Carico radiale di catalogo (uscita)	Catalogue radial load (output)	Radialkraft aus dem Katalog (Ausgang)
$F_{r2b(x)}$ [N]	Carico radiale ammissibile in posizione "X" sull'albero di uscita. Basato sulla vita dei cuscinetti.	Permissible radial load at position "X" on output shaft. Based on bearing lifetime.	Zulässige Radialkraft an der Position "X" der Ausgangswelle, basierend auf der Lagerlebensdauer.
$F_{r2s(x)}$ [N]	Carico radiale ammissibile come $F_{r2b(x)}$ . Basato sulla resistenza a flessione e torsione dell'albero.	Permissible radial load same as $F_{r2b(x)}$ . Based on shaft bending and torsional stress.	Zulässige Radialkraft wie $F_{r2b(x)}$ aber basierend auf Biegung und Verdrehung der Ausgangswelle.
FS	Fattore di servizio Service factor Betriebsfaktor	$FS = \frac{M_2}{M_{(app)}}$	
$i_n$	Rapporto di riduzione nominale	Nominal reduction ratio	Nominelle Übersetzung
$i_r$	Rapporto di riduzione reale	Actual reduction ratio	Tatsächliche Übersetzung
$J_1$ [kgm <sup>2</sup> ]	Momento d'inerzia del riduttore all'albero di entrata del riduttore	Moment of inertia of the gearbox at gearbox input shaft	Trägheitsmoment des Getriebes an der Eingangswelle
$J_2$ [kgm <sup>2</sup> ]	Momento d'inerzia dell'applicazione	Moment of inertia of the application	Trägheitsmoment der Anwendung
$J_m$ [kgm <sup>2</sup> ]	Momento d'inerzia del motore	Moment of inertia of the motor	Trägheitsmoment des Motors
$k_{(a)}$	Fattore d'accelerazione delle masse	Mass acceleration factor	Beschleunigungsfaktor der Massen
$k_{(t)}$	Fattore dell'elemento della trasmissione	Transmission element factor	Kennwert des Übertragungs-Elements
Lub H/V [l]	Lubrificante (litri) H - Montaggio orizzontale V - Montaggio verticale	Lubricant (litres) H - Horizontal mounting V - Vertical mounting	Schmierstoff (Liter) H - waagrechte Einbaulage V - senkrechte Einbaulage
$M_2$ [Nm]	Coppia massima di uscita del riduttore Gearbox maximum output torque Abtriebsdrehmoment des Getriebes	$M_2 = \frac{9550 * P_1 * \eta}{n_2}$	
$M_{(app)}$ [Nm]	Coppia dell'applicazione	Application torque	Erforderliches Drehmoment der Anwendung
$n_1$ [min <sup>-1</sup> ]	Velocità di entrata	Input speed	Eingangsdrehzahl
$n_2$ [min <sup>-1</sup> ]	Velocità di uscita	Output speed	Ausgangsdrehzahl
$P_1$ [kW]	Potenza in entrata Input power Motorleistung	$P_1 = \frac{M_2 * n_2}{9550 * \eta}$	
$P_{(kg)}$ [kg]	Peso per montaggio B3H e rapporto di riduzione medio	Weight: for mounting B3H and average reduction ratio	Gewicht für Bauform B3H und durchschnittliche Getriebeübersetzungen
$\eta$	Rendimento Efficiency Wirkungsgrad	$\eta = 0.96$ - 2 coppie, stages, Stufen $\eta = 0.94$ - 3 coppie, stages, Stufen	

## RN Riduttori - Gearboxes - Getriebe

Sistema modulare - Modular System - Modularesystem

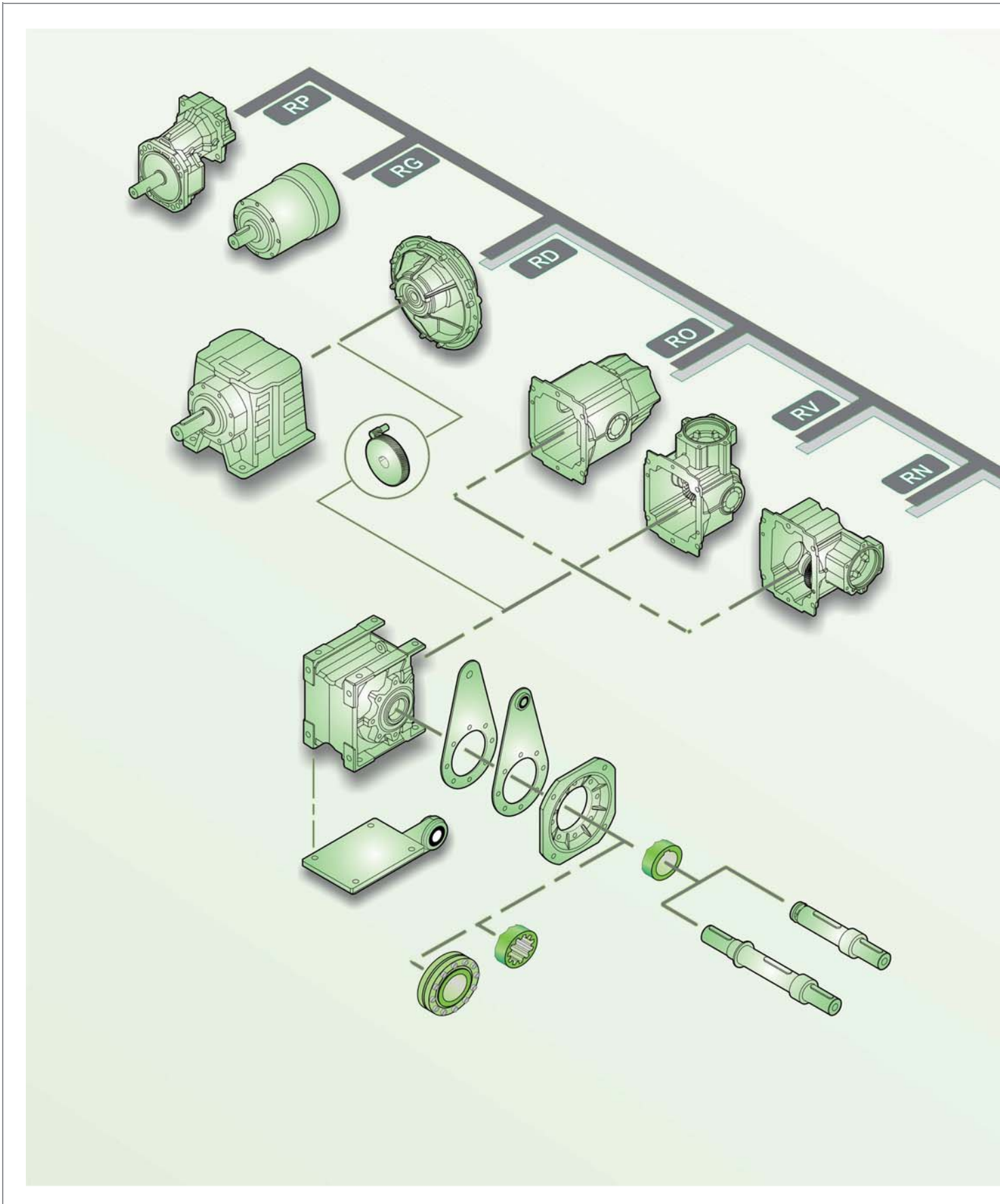



# Getriebe - Gearboxes - Riduttori RN

Modularsystem - Modular System - Sistema modulare

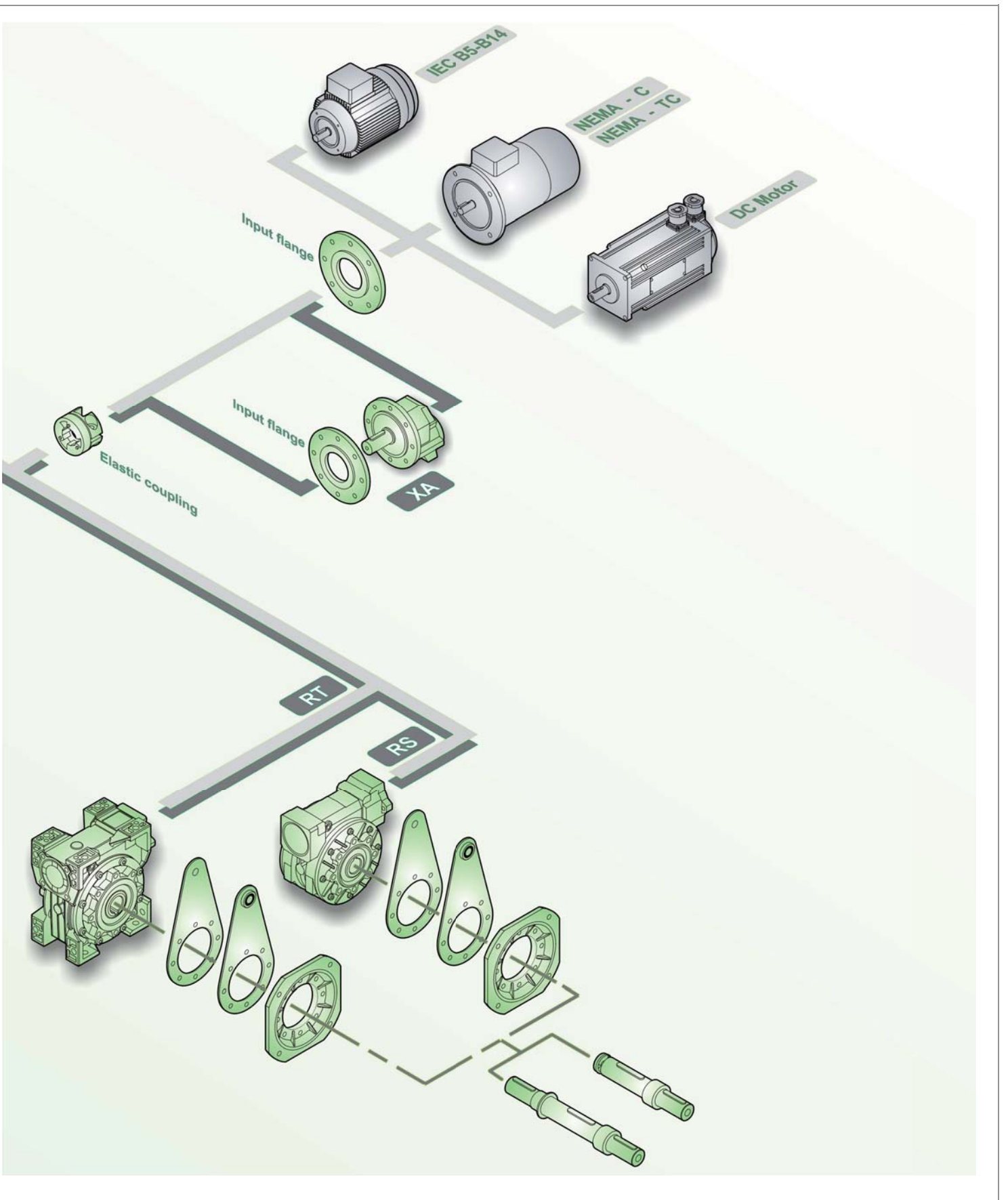

## RN Riduttori - Gearboxes - Getriebe

Descrizione Giunto "G" - Coupling "G" Description - Kuplung "G" Beschreibung

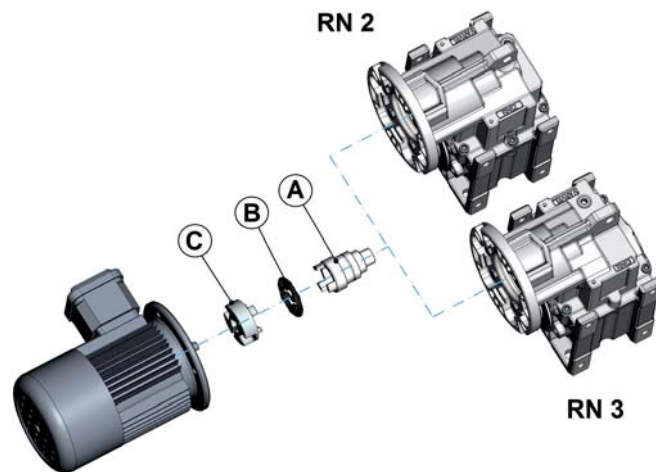

### A) Semi-giunto riduttore

- Materiale: acciaio
- Integrale con albero entrata
- Supportato con due cuscinetti
- Dimensioni lato entrata invariate

### B) Anello elastico

- Denti: collegati esternamente
- Materiale: Elastomero Termoplastico
  - Hytrel® TPE - Poliestere
  - IXEF® TPA - Polirilammide
- Durezza
 

TPE	72 Shore D
TPA	90 Shore D
- Temperatura
 

TPE	-30/+100° C (-22/+212°F)
TPA	-30/+135° C (-22/+275°F)

### C) Semi-giunto motore

- Materiale:
  - Alluminio pressofuso (G3, G5, G6)
  - Acciaio (GS3, GS5, GS6, GS8)
- Bilanciatura dinamica
- Calettamento:
  - Morsetto (G3, G5, G6)
  - Chiavetta (GS3, GS5, GS6, GS8)
- Fori disponibili secondo:
  - IEC 72 / DIN42948
  - NEMA C e TC

### Vantaggi:

- Un solo riduttore per rapporto di riduzione
- Maggiore flessibilità
- Aumentata rotazione dello stock
- Eliminazione sfregamento fra chiavetta e cava (tribocorrosione)
- Collegamento riduttore / motore con gioco zero
- Disallineamento angolare ammesso max 1°
- Elevata rigidità torsionale
- Elevato smorzamento delle vibrazioni

### Flange entrata:

- Materiale:
  - Alluminio fino IEC112 e NEMA TC180
  - Ghisa da IEC 132 e NEMA TC200

### A) Reducer-side coupling hub

- Material: steel
- One piece machined on input shaft
- Two bearing setting
- Unchanged casing dimensions

### B) Spider

- External tooth connection
- Material: Thermoplastic Elastomer:
  - Hytrel® TPE - Polyester
  - IXEF® TPA - Polyarilamide
- Hardness
 

TPE	72 Shore D
TPA	90 Shore D
- Temperature
 

TPE	-30/+100°C (-22/+212°F)
TPA	-30/+135°C (-22/+275°F)

### C) Motor-side coupling hub

- Material:
  - Alu pressure die cast (G3, G5, G6)
  - Steel (GS3, GS5, GS6, GS8)
- Dynamic balancing
- Fitting:
  - Clamp (G3, G5, G6)
  - Key (GS3, GS5, GS6, GS8)
- Bores, available according to:
  - IEC 72 / DIN42948
  - NEMA C and TC

### Advantages:

- One gearbox only for each reduction ratio
- Greater flexibility
- Increased stock rotation
- Elimination of fretting corrosion between key and keyway
- Gearbox / motor connection with zero backlash
- Allowed angular misalignment 1° max.
- High torsional rigidity
- High vibration damping

### Input flanges:

- Material:
  - Aluminium up to IEC112 & NEMA TC180
  - Cast iron from IEC 132 & NEMA TC200

### A) Getriebekupplungshäfte

- Material: Stahl
- integrata Eingangswelle
- Zwei-Lager-Anordnung
- unveränderte Eingang Abmessungen

### B) Kupplungsscheibe

- Äußerliche Zahnverbindung
- Material Thermoplastisch Elastomer:
  - Hytrel® TPE - Polyester
  - IXEF® TPA - Polyarilamide
- Härte
 

TPE	72 Shore D
TPA	90Shore D
- Temperatur
 

TPE	-30/+100° C (-22/+212°F)
TPA	-30/+135° C (-22/+275°F)

### C) Motorkupplungshäfte

- Material:
  - Aluminium Druckguss (G3, G5, G6)
  - Stahl (GS3, GS5, GS6, GS8)
- dynamische Auswuchtung
- Verkeilung:
  - Klammer (G3, G5, G6)
  - Keil (GS3, GS5, GS6, GS8)
- Bohrungen, nach:
  - IEC 72 / DIN42948
  - NEMA C u. TC

### Vorzüge:

- nur eine Getriebekomponente je Übersetzung
- gesteigerte Flexibilität
- höher Lagerumschlag
- Vermeidung von Passungsost zwischen Keil u. Keil Einschnitt
- Getriebe / Motor Spielfrei Verkeilung
- erlaubt Winkelausgleich bis 1°
- hohe Verdrehsteifigkeit
- hohe Dämpfung von Schwingungen

### Eingangsflansche:

- Material:
  - Aluminium bis IEC112 u. NEMA C180
  - Grauguss ab IEC 132 u. NEMA C200

## Getriebe - Gearboxes - Riduttori RN

### Kuplungsauswahl - Flexible Coupling Selection - Selezione Giunto elastico "G"

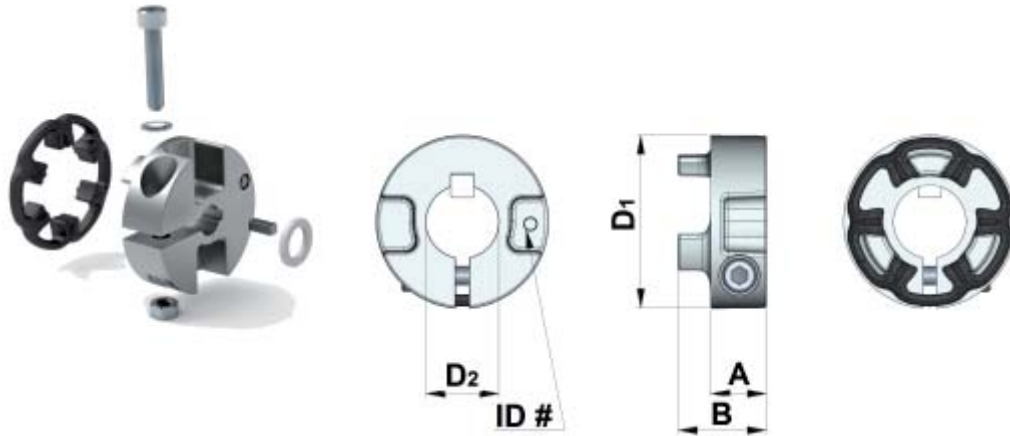

Tipo Type Typ	IEC NEMA	Codice Kit Kit Part No. Kit Teil Nr.	RN	Mt [Nm]	Mt <sub>1</sub> [Nm]	Mt <sub>2</sub> [Nm]	A [mm]	B [mm]	D <sub>1</sub> [mm/ inch]	D <sub>2</sub> [mm/ inch]	ID#
G5	IEC	KG5.009/X	RN12-13	10	14	10	14.5	23	45	9	509
		KG5.011/X	RN12-13		15	10			45	11	511
KG5.014/X		RN12-13	30		17	45			14	514	
KG5.019/X		RN12-13	40		25	45			19	519	
KG5.024/X		RN12-13	70		40	52			24	524	
	NEMA	KG5.N56/X KG5.N140/X	RN12-13 RN12	45 60	35 45	1.77 2.05	5/8" 7/8"	5N56 5N140			
G6	IEC	KG6.014/X	RN22-23-32-33-42-43	18	60	40	19.5	31.5	58	14	614
		KG6.019/X	RN22-23-32-33-42-43		90	65				19	619
KG6.024/X		RN22-32-33-42-43	130		100	24				624	
KG6.028/X		RN22-32-42-43	180		120	28				628	
		NEMA	KG6.N56/X KG6.N140/X KG6.N180/X		RN22-23-32-33-42-43 RN22-32-33-42-43 RN42-43	50 85 200				--- --- ---	2.28
GS8	IEC	KGS8.19/X	RN52-53-62-63	15	150	---	35	51	79	19	*
		KGS8.24/X	RN52-53-62-63		250	---				24	*
KGS8.28/X		RN52-53-62-63	350		---	28				*	
KGS8.38/X		RN52-53-62-63	500		---	38				*	
KGS8.42/X		RN62-63	500		---	42				*	
KGS8.48/X	RN62	500	---	48	*						
	NEMA	KGS8.N056/X KGS8.N140/X KGS8.N180/X KGS8.N210/X KGS8.N250/X	RN52-53-62-63 RN52-53-62-63 RN52-53-62-63 RN62-63 RN62	140 200 300 500 500	--- --- --- --- ---	3.11	5/8" 7/8" 1-1/8" 1-3/8" 1-5/8"	* * * * *			

../X - Codice giunto con elemento elastico nero IXEF

Mt - Coppia di serraggio vite

Mt<sub>1</sub> - Coppia trasmissibile con chiavetta

Mt<sub>2</sub> - Coppia trasmissibile senza chiavetta

\* - Giunto GS8: serraggio con chiavetta e grano di bloccaggio assiale

**Nota** - Nessun ID# marcato sul Giunto GS8

../X - Code of coupling with IXEF black-spider

Mt - Screw locking torque

Mt<sub>1</sub> - Transmissible torque with key

Mt<sub>2</sub> - Transmissible torque without key

\* - Coupling GS8: steel, key fit and grub screw

**Note** - No ID# marked on Coupling GS8

../X - Kupplungscode mit schwarzen IXEF-Ring

Mt - Schraubenklemmengrehmoment

Mt<sub>1</sub> - übertragbar Drehmoment mit Keil

Mt<sub>2</sub> - übertragbar Drehmoment ohne Keil

\* - Kupplung GS8: Stahl, Keilverkeilung u. gewindestift

**Anmerkung** - Kein ID# auf dem Kupplung GS8 markiert ist

## RN Riduttori - Gearboxes - Getriebe

### Flange IEC e Giunto - IEC Flanges & Coupling - IEC-Flansche u. Kupplung

Tipo Riduttore Gearbox Type Getriebestyp	Tipo Flangia Flange Type Flanschtyp	IEC	Codice Kit - Kit Part No. - Kit Teil Nr.		Giunto - Coupling - Kupplung	
			Flange B5	Flange B14	Tipo - Type - Typ	Kit Part No.
RN12	FM 50	IEC56	K532.206.120	---	G5 ø9	KG5.009/X
		IEC63	K532.206.140	K532.206.090	G5 ø11	KG5.011/X
		IEC71	K532.206.160	K532.206.105	G5 ø14	KG5.014/X
		IEC80	K532.206.200	K532.206.120	G5 ø19	KG5.019/X
		IEC90	K532.206.200	K532.206.140	G5 ø24	KG5.024/X
RN13		IEC56	K532.206.120	---	G5 ø9	KG5.009/X
		IEC63	K532.206.140	K532.206.090	G5 ø11	KG5.011/X
		IEC71	K532.206.160	K532.206.105	G5 ø14	KG5.014/X
RN22	FM 70	IEC71	K533.206.160	K533.206.105	G6 ø14	KG6.014/X
		IEC80	K533.206.200	K533.206.120	G6 ø19	KG6.019/X
		IEC90	K533.206.200	K533.206.140	G6 ø24	KG6.024/X
		IEC 100/112	K533.206.250	K533.206.160	G6 ø28	KG6.028/X
RN23		IEC71	K533.206.160	K533.206.105	G5 ø14	KG5.014/X
		IEC80	K533.206.200	K533.206.120	G5 ø19	KG5.019/X
RN32 RN33	FM 70	IEC71	K533.206.160	K533.206.105	G6 ø14	KG6.014/X
		IEC80	K533.206.200	K533.206.120	G6 ø19	KG6.019/X
		IEC90	K533.206.200	K533.206.140	G6 ø24	KG6.024/X
		* IEC 100/112	K533.206.250	K533.206.160	G6 ø28	KG6.028/X
RN42 RN43	FM 85	IEC71	K534.206.160	---	G6 ø14	KG6.014/X
		IEC80	K534.206.200	K534.206.120	G6 ø19	KG6.019/X
		IEC90	K534.206.200	K534.206.140	G6 ø24	KG6.024/X
		IEC 100/112	K534.206.250	K534.206.160	G6 ø28	KG6.028/X
RN52	FM 130 & FM 150	IEC 80	K536.206.200	---	** GS8 ø19	KGS8.019/X
		IEC 90	K536.206.200	---	** GS8 ø24	KGS8.024/X
		IEC 100/112	K536.206.250	---	** GS8 ø28	KGS8.028/X
		IEC 132	K537.206.300	K536.206.200	** GS8 ø38	KGS8.038/X
		IEC 160	K565.206.350	---	** GS8 ø42	KGS8.042/X
		IEC 180	K565.206.350	---	** GS8 ø48	KGS8.048/X
RN53	FM 130	IEC 80	K536.206.200	---	** GS8 ø19	KGS8.019/X
		IEC 90	K536.206.200	---	** GS8 ø24	KGS8.024/X
		IEC 100/112	K536.206.250	---	** GS8 ø28	KGS8.028/X
		IEC132	K537.206.300	K536.206.200	** GS8 ø38	KGS8.038/X
RN62	FM 130 & FM 150	IEC 80	K536.206.200	---	** GS8 ø19	KGS8.019/X
		IEC 90	K536.206.200	---	** GS8 ø24	KGS8.024/X
		IEC 100/112	K536.206.250	---	** GS8 ø28	KGS8.028/X
		IEC 132	K537.206.300	K536.206.200	** GS8 ø38	KGS8.038/X
		IEC 160	K565.206.350	---	** GS8 ø42	KGS8.042/X
		IEC 180	K565.206.350	---	** GS8 ø48	KGS8.048/X
RN63		IEC 80	K536.206.200	---	** GS8 ø19	KGS8.019/X
		IEC 90	K536.206.200	---	** GS8 ø24	KGS8.024/X
		IEC 100/112	K536.206.250	---	** GS8 ø28	KGS8.028/X
		IEC 132	K537.206.300	K536.206.200	** GS8 ø38	KGS8.038/X
		IEC160	K565.206.350	K536.206.250	** GS8 ø42	KGS8.042/X

\* - IEC100/112: no per RN33  
 \*\* - Giunto GS8: montaggio con chiavetta e grano di bloccaggio assiale  
 ../X - Codice del giunto con anello nero IXEF

\* - IEC100/112: not for RN33  
 \*\* - Coupling GS8: key fitting and axial locking grub screw  
 ../X - Code of coupling with IXEF black-spider

\* - IEC100/112: nicht für RN33  
 \*\* - Kupplung GS8: Keilmontage u. gewindestift  
 ../X - Kupplungscode mit schwarzen IXEF-Ring

## Getriebe - Gearboxes - Riduttori RN

### NEMA-Flansche u. Kupplung - NEMA Flanges & Coupling - Flange NEMA e Giunto

Tipo Riduttore Gearbox Type Getriebetyp	Tipo Flangia Flange Type Flanschtyp	NEMA	Codice Kit Flangia Flange Kit Part No. Flansch Kit Teil Nr.	Giunto - Coupling - Kupplung	
				Tipo - Type - Typ	Kit Part No.
RN12	FM 50	56 C 140 TC	K532.227.N56 K532.227.N56	G5 ø 5/8" G5 ø 7/8"	KG5.N56/X KG5.N140/X
RN13		56 C	K532.227.N56	G5 ø 5/8"	KG5.N56/X
RN22	FM 70	56 C 140 C	K533.227.N56 K533.227.N56	G6 ø 5/8" G6 ø 7/8"	KG6.N56/X KG6.N140/X
RN23		56 C	K533.227.N56	G5 ø 5/8"	KG5.N56/X
RN32 RN33	FM 70	56 C 140 TC	K533.227.N56 K533.227.N56	G6 ø 5/8" G6 ø 7/8"	KG6.N56/X KG6.N140/X
RN42 RN43	FM 85	56 C 140 TC 180 TC	K534.227.N56 K534.227.N56 K534.227.N180	G6 ø 5/8" G6 ø 7/8" G6 ø 1-1/8"	KG6.N56/X KG6.N140/X KG6.N180/X
RN52 RN53	FM 150	56 C 140 TC 180 TC 210 TC	K537.227.N56 K537.227.N56 K537.227.N180 K537.227.N180	* GS8 ø 5/8" * GS8 ø 7/8" * GS8 ø 1-1/8" * GS8 ø 1-3/8"	KGS8.N56/X KGS8.N140/X KGS8.N180/X KGS8.N210/X
RN62 RN63	FM 150	56 C 140 TC 180 TC 210 TC 250 TC	K537.227.N56 K537.227.N56 K537.227.N180 K537.227.N180 K537.227.N180	* GS8 ø 5/8" * GS8 ø 7/8" * GS8 ø 1-1/8" * GS8 ø 1-3/8" * GS8 ø 1-5/8"	KGS8.N56/X KGS8.N140/X KGS8.N180/X KGS8.N210/X KGS8.N250/X

\* - Giunto GS8: serraggio con chiavetta e grano di bloccaggio assiale  
 ../X - Codice del giunto con anello nero IXEF

\* - Coupling GS8: key fitting and axial locking grub screw  
 ../X - Code of coupling with IXEF black-spider

\* - Kupplung GS8: Keilmontage u. gewindestift  
 ../X - Kupplungscode mit schwarzen IXEF-Ring



# RN Riduttori - Gearboxes - Getriebe

## Designazione Riduttore e Motore - Gearbox & Motor Designation - Getriebe- u. Motorbezeichnungen

### DESIGNAZIONE DEL RIDUTTORE - GEARBOX DESIGNATION - GETRIEBEBEZEICHNUNG

**F RN 32 /B3 H 31.5 IEC71 -B14 AU30 DFU200**

Flangia uscita  $\emptyset$  - Output flange - Ausgangsflansch

Albero uscita  $\emptyset$  - Output shaft  $\emptyset$  - Ausgangswelle  $\emptyset$

B5, B14 = Forma del motore - Motor form - Motorbauform

Grandezza del motore elettrico - Electric motor frame - Motorbaugröße

Rapporto di riduzione - Reduction ratio - Getriebeübersetzung

H, V = Posizione di montaggio del riduttore - Gearbox mounting position - Einbaulage des Getriebes

B3, B5, B3/B5 = Forma costruttiva del riduttore - Gearbox form - Bauform des Getriebes

Grandezza e coppie del riduttore - Gearbox size and stages - Baugröße u. Stufen des Getriebes

RN = Tipo del riduttore - Gearbox type - Getriebetyp

M = Motorriduttore	- Geared motor	- Getriebemotor
F = Riduttore con entrata IEC	- Gearbox with input flange	- Getriebe mit Eingangsflansch
S = Riduttore senza flangia entrata IEC	- Gearbox without input flange	- Getriebe ohne Eingangsflansch
... = (nulla) Riduttore con albero entrata sporgente	- (nothing) Gearbox with input free shaft	- (kein) Freie Eingangswelle

### DESIGNAZIONE DEL MOTORE- MOTOR DESIGNATION - MOTORBEZEICHNUNG

**MT 0.37 kW 71 B 4 B14 230/400/50 IP55 F X4**

Posizione della morsettiera  
Terminal box position  
Klemmkastenposition

Classe F (std) = Classe isolamento  
Insulation class  
Isolationsklasse

IP55 (std) = Grado di protezione - Protection class - Schutzart

Tensione / Frequenza - Voltage/frequency - Spannung/Frequenz

B5 o B14 = Forma costruttiva - Mounting form - Bauform

Numero poli - Number of poles - Polzahl

Grandezza IEC del motore - IEC motor frame - IEC-Motorbaugröße

Potenza del motore - Motor power - Motorleistung

MT = Motore trifase	- Three-phase motor	- Dreiphasenmotor
MM = Motore monofase	- Single-phase motor	- Einphasenmotor
MA = Motore autofrenante	- Brake motor	- Bremsmotor

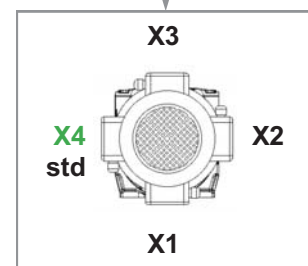

# Getriebe - Gearboxes - Riduttori RN

Elektronischer Katalog - Guided Selection - Configurazione assistita VARsize



## Modularità e la flessibilità

hanno guidato il progetto dei prodotti VARVEL fino dagli anni 2000: così, la disponibilità di riduttori in kit ha permesso il montaggio in pochi minuti utilizzando una normale attrezzatura.

Questo permette la massima flessibilità ai distributori e rivenditori VARVEL che, grazie ad un numero limitato di elementi, possono configurare all'istante il prodotto richiesto dai clienti.

Il programma di selezione **VARsize**® disponibile nel sito web

[www.varvel.com](http://www.varvel.com)

permette un facile dimensionamento dei prodotti VARVEL.

## Disegni 2D/3D

Tramite configurazione assistita si generano modelli 3D e disegni 2D nei formati CAD più diffusi.

## Configurazione assistita

Identifica, fra tutte le serie, i riduttori che sono adeguati per soddisfare i parametri di funzionamento richiesti (potenza, coppia, velocità, fattore di servizio, ecc.). Definita la grandezza del riduttore, un documento è generato dai dati della richiesta, così come il disegno dimensionale PDF, il modello 3D e il disegno 2D.

## Modularity and flexibility

have been leading the design of VARVEL products since the years 2000: this way, the gearbox-kit concept was carried out allowing anyone to assemble the unit in few minutes with standard tooling.

This feature provides the highest flexibility to VARVEL's distributors and resellers who - thanks to a limited kit selection - are able to immediately configure the required product.

**VARsize**® selection program, available from our web-site

[www.varvel.com](http://www.varvel.com)

allows a friendly sizing of VARVEL product range.

## 2D/3D Drawings

A guided selection lets 2D/3D models downloaded for the most popular CAD systems.

## Guided selection

This option returns a list of applicable product configurations upon a given sequence of application parameters (power, output torque, rpm, service factor etc.); a PDF data sheet featuring performance data and dimensional drawings is generated for each configuration, as well as the 3D model and 2D drawings.

## Bausteinprinzip und Flexibilität

bestimmen die Gestaltung der VARVEL Produkte seit 2000. Dieses Konzept ermöglicht jedermann in kurzer Zeit mit Standardwerkzeugen das gewünschte Getriebe zu montieren.

Damit wird allen Verkäufern von VARVEL-Antrieben ein Höchstmaß an Flexibilität gegeben, um mit wenigen Bauteilen ein gewünschtes Getriebe zu konfigurieren.

**VARsize**® als Auswahlprogramm auf unserer Internetseite

[www.varvel.com](http://www.varvel.com)

bietet eine angepasste Antriebsauslegung.

## 2D/3D-Zeichnungen

Die unterstützte Auswahl bietet die Möglichkeit 2D/3D Modelle für die gängigen CAD Systeme zu laden.

## Unterstützte Auswahl

Mit diesem Dienst wird eine Liste möglicher Produktvarianten erzeugt, bestimmt durch Parameter (Leistung, Moment, Drehzahl, Betriebsfaktor usw.); ein PDF Datenblatt mit Leistungsdaten und Maßbild ist für jede dieser Konfigurationen verfügbar, ebenso wie 3D Modelle und 2D Zeichnungen.

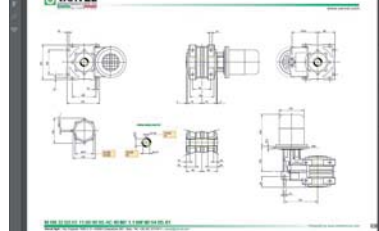

## RN Riduttori - Gearboxes - Getriebe

Posizioni di montaggio - Mounting positions - Einbaulagen

### RN

- due e tre coppie
- two and three stages
- Zwei- u. Dreistufig

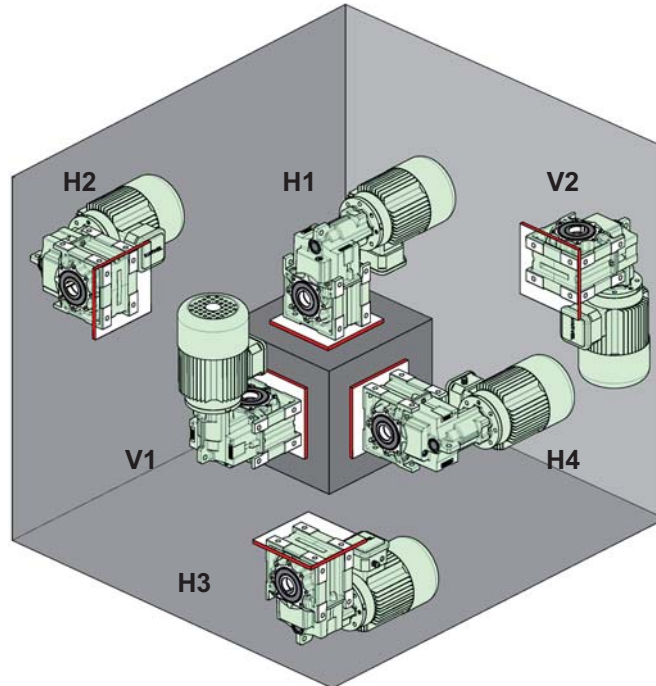

**B3**  
Montaggio a piedi  
Foot mounting  
Fußbauformen

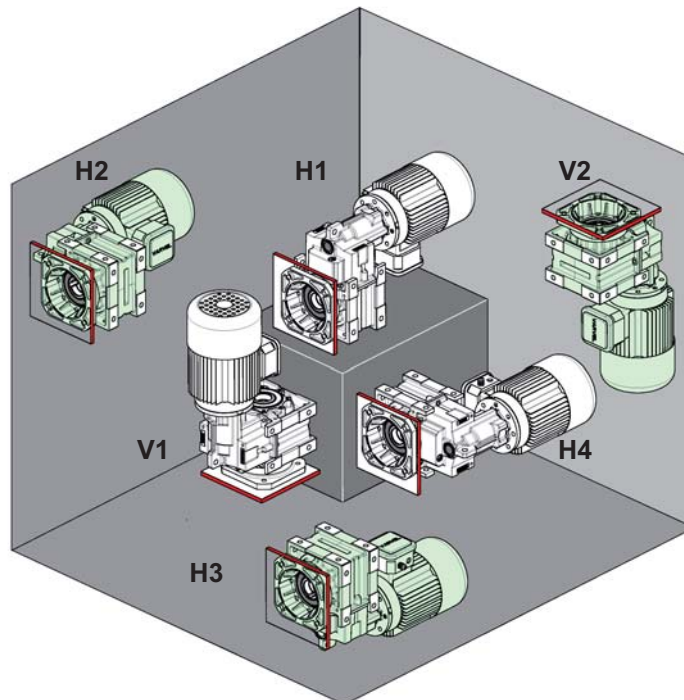

**B5**  
Montaggio a flangia  
Flange mounting  
Flanschbauformen

# Getriebe - Gearboxes - Riduttori RN

## Betriebsfaktoren - Service factors - Fattori di servizio

### FATTORE DI SERVIZIO del riduttore

Il fattore di servizio FS1.0 è inteso come rappresentativo di un funzionamento di 8 ore al giorno, con carico uniforme e fattore di accelerazione delle masse  $k_{(a)} \leq 0.2$ , avviamenti inferiori a 300 all'ora e temperatura ambiente fra 15 e 35 °C.

Le prestazioni riportate nelle tabelle permettono di calcolare il fattore di servizio come rapporto fra la coppia massima di uscita del riduttore  $M_2$  e la coppia richiesta dalla applicazione  $M_{(app)}$ .

Non è necessario tener conto della potenza termica (v. pag.19) quando la durata massima di servizio continuativo è di circa 3 h seguita da pause sufficienti (circa 2 - 4 h) a ristabilire nel riduttore la temperatura ambiente.

Per temperatura massima ambiente maggiore di 40 °C oppure minore di 0 °C interpellare il Servizio Clienti.

### SERVICE FACTOR of the gearbox

Service factor FS1.0 is meant as typical of 8 hours/day operation, with uniform load and mass acceleration factor  $k_{(a)} \leq 0.2$ , starts/ stops lower than 300 per hour and ambient temperature between 15 and 35 Celsius.

The performance shown in the tables gives the service factor calculation as a ratio between gearbox maximum output torque  $M_2$  and application torque  $M_{(app)}$ .

Thermal power (see page19) can be not considered when the max. continuous operation is about 3 hours with long enough rest periods (about 2 to 4 hours) to restore the ambient temperature into the gearbox.

For max. ambient temperature exceeding 40 °C or below 0 °C, please ask our Customer Service.

### BETRIEBSFAKTOR des Getriebes

Für den Servicefaktor FS1.0 gilt ein 8- bis 10-stündiger Betrieb mit gleichförmiger Last und einem Massenbeschleunigungsfaktor  $k_{(a)} J_2 \leq 2$ , bis zu 300 Starts/Stops je Stunde und Umgebungstemperaturen zwischen 15° und 35 °C.

Die in den Tabellen dargestellten Daten ermöglichen eine Bestimmung des genauen Betriebsfaktors aus dem max. Abtriebsmoment des Getriebes  $M_2$  und dem erforderlichen Moment der Anwendung  $M_{(app)}$ .

Thermische Leistung (siehe Seite 19) können nicht berücksichtigt, wenn die max. Dauerbetrieb etwa 3 Stunden lang genug Ruhezeiten (ca. 2 bis 4 Stunden), um die Umgebungstemperatur in dem Getriebe wiederherzustellen.

Für max. Umgebungstemperatur über 40° C oder unter 0° C, fragen Sie bitte unseren Kundenservice.

### Fattore di accelerazione delle masse Mass acceleration factor Beschleunigungsfaktor der Massen

$$k_{(a)} = \frac{J_2}{i r^2} + J_1$$

Classi di carico  
Load class  
Belastungsklassen

- A - Carico uniforme  
Uniform load  
Gleichförmige Last  
 $k_{(a)} \leq 0,2$
- B - Carico con urti moderati  
Moderate shock load  
Ungleichförmige Last  
 $0,2 > k_{(a)} \leq 3$
- C - Carico con forti urti  
Severe shock load  
Stark ungleichförmige Last  
 $3 < k_{(a)} \leq 10$

A/h - Numero di avviamenti/ora  
Number of starts/stops per hour  
Anzahl der Schaltungen je Stunde

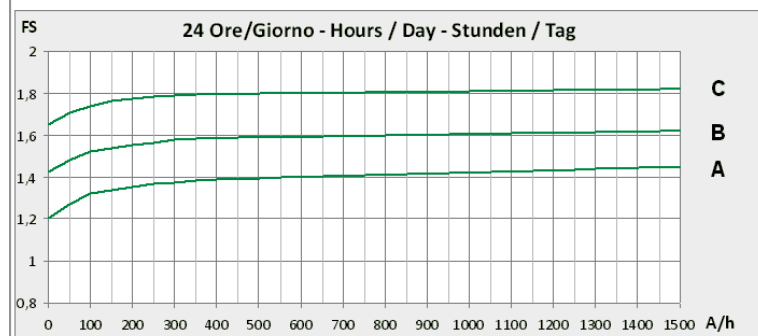
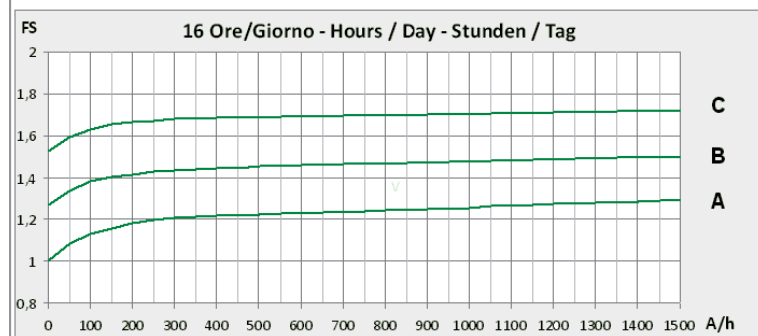
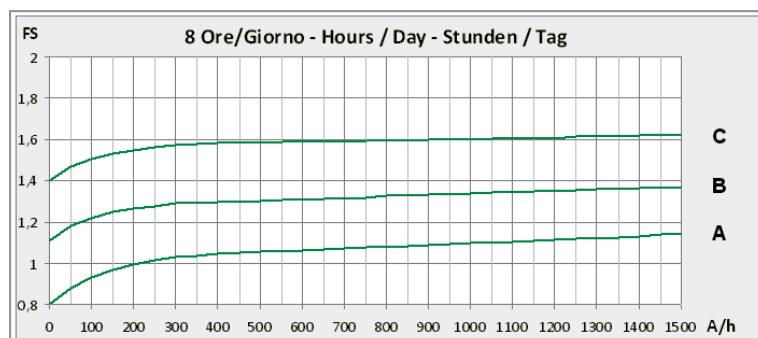

# RN Riduttori - Gearboxes - Getriebe

## Fattori di servizio - Service factors - Betriebsfaktoren

### TIPO DI SERVIZIO del motore

Le specifiche dei vari tipi di servizi sono definiti dalle norme CEI EN 60034-1 / IEC34-1.

### S1 - Servizio continuo

Funzionamento a carico costante per un periodo di tempo indefinito (N), comunque sufficiente a raggiungere l'equilibrio termico.

### DUTY TYPE of the motor

The specifications of various duty types are defined by the Standard CEI EN 60034-1 / IEC34-1.

### S1 - Continuous duty

Steady load operation for an indefinite period (N), but long enough to achieve thermal balancing.

### BETRIEBSARTEN des Motors

Die Betriebsarten sind definiert in den Normen CEI EN 60034-1 / IEC34-1.

### S1 - Dauerbetrieb

Betrieb mit konstanter Belastung über eine unbestimmte Zeit (N), ohne dass der thermische Beharrungszustand der Maschine beeinträchtigt wird.

**FS = 1.0**

- N = Tempo di lavoro  
Operation time  
Betriebszeit
- c = Carico  
Load  
Belastung
- t = Temperatura  
Temperature  
Temperatur

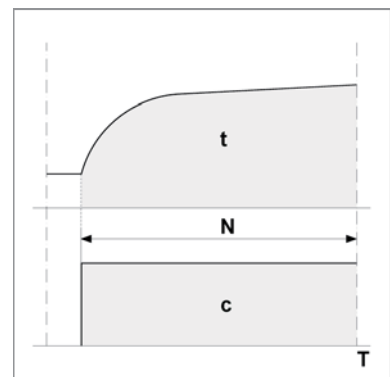

### S3 - Servizio intermittente periodico

Funzionamento secondo un ciclo (C) comprendente un periodo di tempo a carico costante (N) ed un periodo di tempo di riposo (R). Gli avviamenti non influiscono sulle temperature. Il ciclo (C) di riferimento è di 10 minuti complessivi. Il rapporto di intermittenza viene determinato secondo la formula.

### S3 - Periodic intermittent duty

Operation according to cycle (C) including steady load time (N) and rest time (R). Starts/stops do not affect temperature. The reference cycle (C) is up to a total of 10 minutes. Intermittence ratio is calculated as follows.

### S3 - Aussetzbetriebe

Betrieb als Folge (C) gleichartiger Spiele mit konstanter Last während der Zeit (N) und einer folgenden Pause (R). Start und Stop beeinflussen nicht die Temperatur. Für die Zyklusdauer (C) gilt eine Zeit von 10 Minuten.

$$\frac{N}{(N+R)} * 100 = \begin{matrix} 60\% & \mathbf{FS = 0.90} \\ 40\% & \mathbf{FS = 0.85} \\ 25\% & \mathbf{FS = 0.75} \\ 15\% & \mathbf{FS = 0.70} \end{matrix}$$

- N = Tempo di lavoro  
Operation time  
Betriebsdauer
- R = Tempo di riposo  
Rest time  
Pause
- C = Ciclo di lavoro  
Duty cycle  
Zyklusdauer

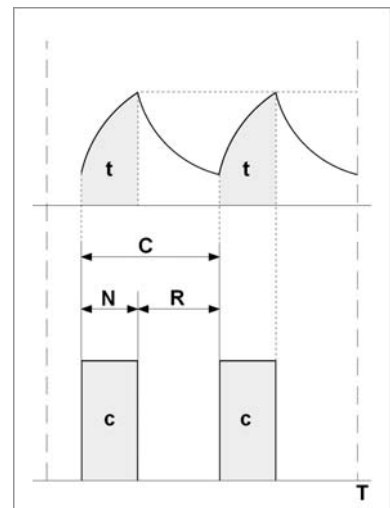



# Getriebe - Gearboxes - Riduttori RN

## Ausgangskräfte - External Loads - Carichi esterni

### CARICHI RADIALI USCITA

I carichi radiali riportati nelle tabelle di selezione dei riduttori debbono essere verificati anche in base al tipo di elemento di trasmissione montato sulla estremità d'albero tramite il relativo fattore  $k_{(t)}$ .

#### - Carico radiale dell'applicazione

Application radial load  
Radialbelastung der Anwendung

$$F_r = \frac{2000 * M_2}{D} * k_{(t)}$$

### AUSGANGSRADIALKRÄFTE

Radialkräfte müssen mit den zulässigen Werten der Auswahltabellen für Getriebe verglichen werden, wobei der Faktor  $k_{(t)}$  des jeweiligen Übertragungselementes berücksichtigt werden muss.

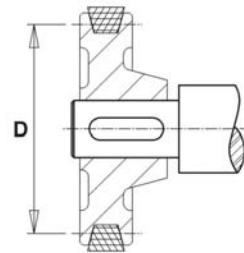

$k_{(t)}$	Elemento della trasmissione	Transmission element	Übertragungselement
1,15	Ingranaggio - N. denti < 17	Gear - Tooth No. < 17	Zahnrad - Zähnezahl < 17
1,40	Pignone per catena - N. denti < 13	Chain sprocket - Tooth No. < 13	Kettenrad - Zähnezahl < 13
1,25	Pignone per catena - N. denti < 20	Chain sprocket - Tooth No. < 20	Kettenrad - Zähnezahl < 20
1,00	Pignone per catena - N. denti > 20	Chain sprocket - Tooth No. > 20	Kettenrad - Zähnezahl > 20
2,50	Puleggia per cinghie "V"	V-belt pulley	Keilriemen "V"
1,25	Puleggia per cinghie dentate	Toothed-belt pulley	Zahnriemen

#### - Carico radiale di catalogo a metà albero

Catalogue radial load at shaft centre  
Katalogwert der Radialbelastung Wellenmitte

[mm]	1	2	3	4	5	6
a	22.5	30.0	30.0	40.0	41.0	52.5

$$F_{r2} \geq F_r$$

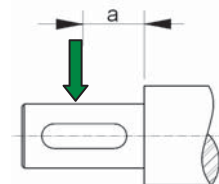

#### - Carico radiale in posizione generica

Radial load offset from centre  
Radialbelastung für allgemeine Positionen

Verificare entrambi i confronti (\*) e (\*\*).  
Check both (\*) and (\*\*) comparisons.  
Überprüfe beide Ergebnisse (\*) und (\*\*)

[mm]	1	2	3	4	5	6
a	22.5	30.0	30.0	40.0	41.0	52.5
b	21.5	24.5	23.5	30.5	32.0	33.0
c	44.0	54.5	53.5	70.5	73.0	85.5

$$(*) \quad F_{r2b(x)} \geq F_r$$

$$F_{r2b(x)} = F_{r2} * \frac{c}{x + b}$$

$$F_{r2s(x)} \geq F_r$$

$$(**) \quad F_{r2s(x)} = F_{r2} * \frac{a}{x}$$

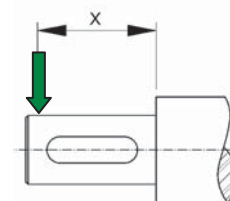

'b, c' = costanti / constants / Konstanten

### CARICHI ASSIALI USCITA

Valore del carico assiale, sia a trazione che a compressione, e in presenza di carico radiale:

### OUTPUT AXIAL LOADS

Axial load value, both on tensile and compressive stress, and with radial load:

### EINGANGSAXIALKRÄFTE

Axialkräfte auf Zug- und Druck bei gleichzeitiger Radialkraft:

$$F_{a2} = F_{r2} * 0.2$$

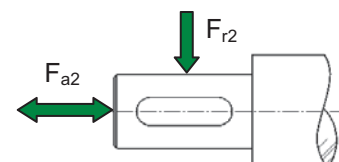

## RN Riduttori - Gearboxes - Getriebe

### Versioni - Versions - Ausführungen

#### MRN

- Motorriduttori a due e tre coppie di ingranaggi  
Potenza: 0.09 kW a 22 kW a 4 poli  
Giri uscita: 250 rpm a 2.5 rpm
- Geared motors with two and three gear sets  
Powers: 0.09 kW to 22 kW, 4 poles  
Output speed: 250 rpm to 2.5 rpm
- Zwei- u. Dreistufige Getriebemotoren  
Leistung: 0.09 kW bis 22 kW, 4-polen  
Ausgangsgeschwindigkeit: 250 UpM bis 2.5 UpM

#### FRN

- Riduttori a due e tre coppie di ingranaggi con flangia motore entrata, albero d'entrata cavo e giunto elastico  
Flange motore: IEC 56 a IEC 180 e NEMA 56C a NEMA 250TC  
Coppia: 120 Nm a 3400 Nm  
Rapporti di riduzione: 6.3:1 a 710:1
- Gearboxes with two and three gear sets and with input motor flange, input quill and flexible coupling  
Motor flanges: IEC 56 to IEC 180 and NEMA 56C to NEMA 250TC  
Output torque: 120 Nm [1060 in-lb] to 3400 Nm [30100 in-lb]  
Reduction ratios: 6.3:1 to 710:1
- Zwei- u. Dreistufige Getriebemotoren mit Motorflansch, Eingangshohlwelle und Kupplung  
Motorflansche: IEC 56 bis IEC 180 u. NEMA 56C bis NEMA 250TC  
Ausgangsdrehmoment: 120 Nm [1060 in-lb] bis 3400 Nm [30100 in-lb]  
Untersetzungsverhältnis: 6.3:1 bis 710:1

#### SRN

- Riduttori a due e tre coppie di ingranaggi senza flangia motore di entrata, ma con albero entrata cavo e giunto elastico  
senza flangia motore entrata e con albero entrata cavo con giunto  
Coppia: 120 Nm [1060 in-lb] a 3400 Nm [30100 in-lb]  
Rapporti di riduzione: 6.3:1 a 710:1
- Gearboxes with two and three gear sets without input motor flange, but with input hollow shaft with flexible coupling  
Output torque: 120 Nm [1060 in-lb] to 3400 Nm [30100 in-lb]  
Reduction ratios: 6.3:1 to 710:1
- Zwei- u. Dreistufige Getriebemotoren ohne Motorflansch, aber mit Hohl-  
eingangswelle und Kupplung  
Ausgangsdrehmoment: 120 Nm [1060 in-lb] bis 3400 Nm [30100 in-lb]  
Untersetzungsverhältnis: 6.3:1 bis 710:1

#### RN

- Riduttori a due e tre coppie di ingranaggi con albero entrata sporgente  
Coppia: 120 Nm [1060 in-lb] a 3400 Nm [30100 in-lb]  
Rapporti di riduzione: 6.3:1 a 710:1
- Gearboxes with two and three gear sets with input solid shaft  
Output torque: 120 Nm [1060 in-lb] to 3400 Nm [30100 in-lb]  
Reduction ratios: 6.3:1 to 710:1
- Zwei- u. Dreistufige Getriebemotoren mit Eingangswelle  
Ausgangsdrehmoment: 120 Nm [1060 in-lb] bis 3400 Nm [30100 in-lb]  
Untersetzungsverhältnis: 6.3:1 bis 710:1

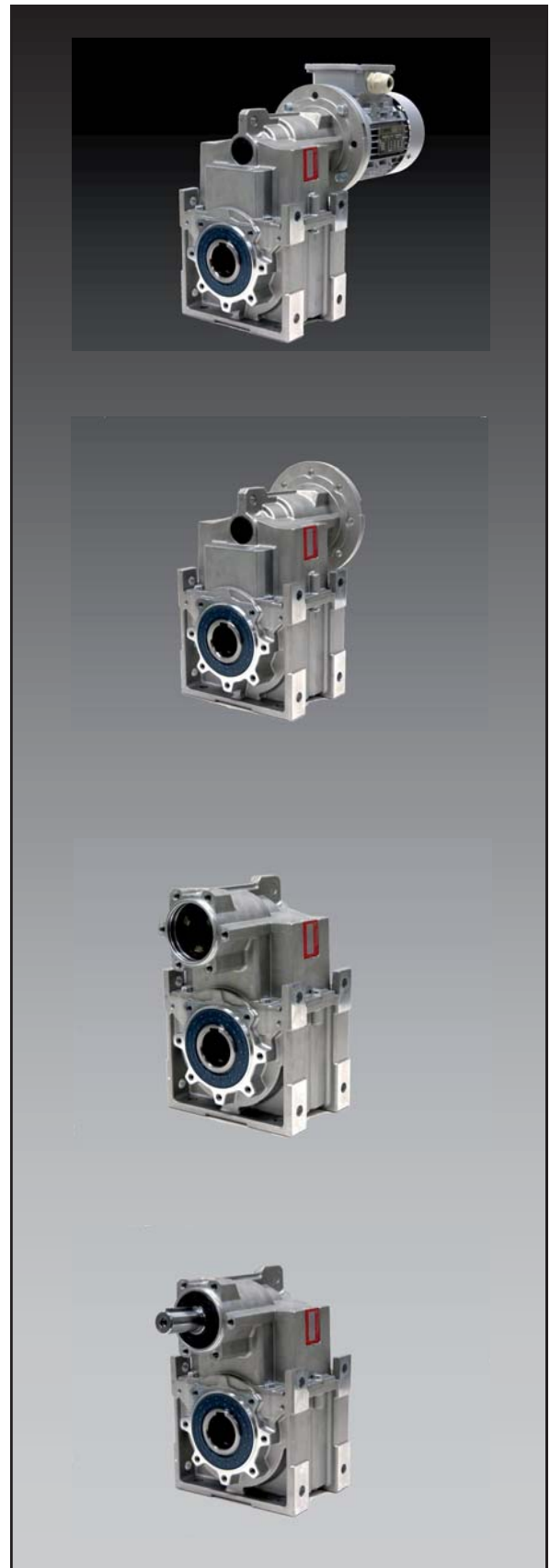

# Getriebe - Gearboxes - Riduttori RN

## Thermische Nennleistung - Thermal power - Potenza termica

### Potenza termica

La **potenza nominale**  $P_1$ , è la potenza che può essere applicata all'entrata del riduttore, in servizio continuo, temperatura max ambiente di 40 °C, altitudine max 1000 m e velocità dell'aria 1,25 m/s, senza superare una temperatura dell'olio di circa 85 °C.

La **potenza termica**  $P_{t1}$  può limitare la nominale  $P_1$  (area in grigio) in funzione del sistema di raffreddamento, della velocità di entrata, della temperatura ambiente e del coefficiente di servizio.

### Thermal power

The **rated power**  $P_1$ , is the power that can be applied at the gearbox input, on continuous operation, max. temperature of 40 °C, max. altitude 1000 m, air speed of 1.25 m/s, without exceeding the oil temperature of about 85 °C.

The **thermal power**  $P_{t1}$  can limit the rated  $P_1$  (grey area) depending on the cooling system, input speed, ambient temperature and service factor.

### Thermische Leistung

Die **Nennleistung**  $P_1$  ist die Leistung, die am Getriebe angewendet werden kann, Dauerbetriebstemperatur von 40 °C max., max. Höhe 1000 m, Luftgeschwindigkeit von 1,25 m/s, ohne mehr als eine Temperatur von Öl von etwa 85 °C.

Die **thermische Leistung**  $P_{t1}$  kann der Nennleistung  $P_1$  (Grauzone) als Funktion des Kühlsystems der Antriebsdrehzahl, Umgebungstemperatur und der Koeffizient der Service begrenzen.

	FRN12-13			FRN22-23			FRN32-33			FRN42-43			FRN52-53			FRN62-63		
	$i_n$	$P_1$ [kW]	$P_{t1}$ [kW]	$i_n$	$P_1$ [kW]	$P_{t1}$ [kW]	$i_n$	$P_1$ [kW]	$P_{t1}$ [kW]	$i_n$	$P_1$ [kW]	$P_{t1}$ [kW]	$i_n$	$P_1$ [kW]	$P_{t1}$ [kW]	$i_n$	$P_1$ [kW]	$P_{t1}$ [kW]
2 c	7.1	2.90	3.70	6.3	5.10	6.80	6.3	10.90	8.10	6.3	18.10	13.60	6.3	29.80	17.70	6.3	60.10	33.89
	8.0	2.50	3.40	7.1	4.60	6.20	7.1	9.20	7.80	7.1	16.60	12.80	7.1	25.80	16.70	7.1	53.70	32.65
	9.0	2.60	3.60	8.0	4.40	5.90	8.0	7.10	7.40	8.0	13.90	11.20	8.0	22.70	15.80	8.0	42.10	29.08
	10.0	2.30	3.40	9.0	4.10	5.80	9.0	8.30	7.30	9.0	15.00	11.90	9.0	22.60	15.40	9.0	47.20	30.86
	12.5	1.60	3.20	10.0	3.60	5.60	10.0	5.70	7.00	10.0	11.00	10.50	10.0	17.30	14.80	10.0	31.90	27.86
	14.0	1.90	3.10	11.2	3.60	5.40	11.2	7.30	6.80	11.2	12.00	10.90	11.2	20.70	14.30	11.2	41.70	28.86
	16.0	1.30	2.90	12.5	2.90	5.20	12.5	4.60	6.80	12.5	8.90	9.80	12.5	13.90	13.70	14.0	34.50	26.41
	18.0	1.50	2.80	14.0	3.20	4.80	14.0	5.80	6.20	14.0	10.00	10.20	14.0	17.40	13.00	16.0	21.20	24.67
	20.0	1.30	2.50	16.0	2.30	4.80	16.0	3.80	6.40	16.0	7.10	9.30	16.0	11.60	12.90	18.0	27.60	23.61
	22.4	1.00	2.20	18.0	2.70	4.50	18.0	4.50	5.50	18.0	8.10	9.30	18.0	13.90	11.60	20.0	17.40	23.07
	31.5	0.70	2.10	20.0	1.80	4.40	20.0	3.00	5.80	22.4	6.30	8.20	20.0	9.50	12.00	22.4	21.30	20.57
	33.0	0.70	1.80	22.4	2.10	3.80	22.4	3.80	5.00	28.0	4.80	7.60	22.4	10.70	10.10	25.0	18.20	21.17
	35.5	0.60	1.70	25.0	1.50	4.10	25.0	2.30	5.10	31.5	3.70	7.20	25.0	7.60	10.80	28.0	18.00	20.00
	40	0.50	1.80	28.0	1.40	3.40	28.0	2.90	4.50	35.5	3.00	6.70	28.0	9.30	9.90	31.5	15.60	18.90
	45	0.50	1.70	31.5	1.20	3.50	31.5	1.90	4.70	40	2.60	6.30	31.5	8.10	9.30	35.5	10.30	16.48
	50	0.40	1.60	35.5	1.00	3.00	35.5	2.00	4.00	45	2.50	6.00	35.5	5.50	8.20	40	12.50	18.17
	56	0.30	1.30	40	0.90	3.20	40	1.60	4.20	50	2.30	5.70	40	4.70	8.70	45	8.30	17.22
	60	0.30	1.30	45	0.80	2.80	45	1.00	3.20	56	1.90	5.20	45	3.70	7.00	50	6.80	15.19
3 c	40	0.60	1.50	50	0.80	2.60	50	1.30	3.80	40	3.30	5.16	50	4.00	7.80	56	6.10	13.81
	50	0.50	1.50	63	0.60	2.40	56	1.20	3.60	45	3.30	5.00	63	3.20	6.60	40	13.30	12.55
	63	0.40	1.40	40	1.10	2.60	63	1.00	3.10	56	2.80	4.76	40	6.90	8.49	50	10.90	12.15
	80	0.40	1.30	45	0.90	2.50	40	2.10	3.70	63	2.30	4.53	45	5.60	8.17	56	9.00	11.72
	100	0.30	1.20	56	0.90	2.40	45	1.90	3.50	71	0.90	3.50	56	4.80	7.85	71	7.30	11.16
	125	0.20	1.10	71	0.70	2.20	56	1.60	3.40	80	1.90	4.25	71	3.90	7.48	80	3.50	8.73
	160	0.20	1.00	80	0.30	1.60	71	1.30	3.20	90	0.90	3.42	90	3.10	6.95	90	5.80	10.43
	180	0.10	0.90	90	0.60	2.10	80	0.50	2.60	100	1.50	3.88	100	1.90	5.91	100	3.50	8.56
	200	0.10	0.90	100	0.30	1.60	90	1.00	2.90	140	1.10	3.66	112	2.40	6.33	125	4.40	9.46
	250	0.10	0.80	112	0.40	1.90	100	0.50	2.50	160	0.70	3.35	125	1.70	5.75	140	3.70	9.22
	280	0.10	0.80	125	0.30	1.60	112	0.80	2.80	180	0.70	3.12	140	2.00	6.26	160	3.30	8.85
	315	0.10	0.80	140	0.30	1.70	125	0.50	2.50	200	0.40	2.98	160	1.80	6.02	200	2.20	8.03
	400	0.10	0.70	160	0.30	1.50	140	0.60	2.60	224	0.60	2.98	180	1.20	5.54	224	1.70	7.47
				180	0.20	1.50	160	0.40	2.40	280	0.50	2.79	224	0.90	5.11	250	1.60	7.48
				200	0.20	1.50	180	0.40	2.40	355	0.40	2.68	315	0.70	4.77	315	1.20	6.95
				224	0.10	1.30	200	0.30	2.30	450	0.30	2.51	355	0.60	4.75	400	1.00	6.83
				250	0.20	1.40	224	0.20	2.00	500	0.30	2.42	400	0.60	4.61	450	0.90	6.62
				315	0.10	1.30	280	0.30	2.20	560	0.20	2.30	450	0.50	4.33	500	0.80	6.15
			400	0.10	1.30	315	0.20	2.10				560	0.40	3.96	560	0.70	5.82	
			450	0.10	1.20	400	0.20	2.00										
			500	0.10	1.10	500	0.10	1.90										
			630	0.10	1.10	560	0.10	1.80										
						710	0.10	1.60										

2c, 3c - Numero delle coppie di riduzione

2c, 3c - Number of reduction stages

2c, 3c - Anzahl der Getriebestufen

## RN Riduttori - Gearboxes - Getriebe

Selezione Riduttore - Speed Reducer Selection - Getriebeauswahl

1400 rpm

	$i_n$	$i_r$	$n_2$ [rpm]	$M_2$ [Nm]	$P_1$ [kW]	$F_{r1}$ [N]	$F_{r2}$ [N]	$J_1 (x 10^{-4})$ [kgm <sup>2</sup> ]	56 B5	63 B*	71 B*	80 B*	90 B14
<b>FRN 12</b> 2c	7,1	6,59	212	125	2,90	1050	3350	0,8414	⊙	⊙	⊙	⊙	⊙
	8,0	7,95	176	130	2,50	1100	3470	0,7600	⊙	⊙	⊙	⊙	⊙
	9,0	8,32	168	140	2,60	1030	3580	0,6786	⊙	⊙	⊙	⊙	⊙
	10,0	10,11	138	150	2,30	1010	3490	0,5849	⊙	⊙	⊙	⊙	⊙
	12,5	12,19	115	130	1,60	1110	3470	0,5416	⊙	⊙	⊙	⊙	⊙
	14,0	13,17	106	165	1,90	1000	3450	0,4982	⊙	⊙	⊙	⊙	⊙
	16,0	15,87	88,2	140	1,30	1110	3450	0,4722	⊙	⊙	⊙	⊙	⊙
	18,0	16,65	84,1	165	1,50	1060	3560	0,4462	⊙	⊙	⊙	⊙	⊙
	20,0	20,29	69,0	170	1,30	1110	3710	0,4149	⊙	⊙	⊙	⊙	⊙
	22,4	25,37	55,2	170	1,00	1130	3850	0,3892	⊙	⊙	⊙	⊙	⊙
	31,5	30,59	45,8	140	0,70	1270	4070	0,3789	⊙	⊙	⊙	⊙	⊙
	33,0	33,00	42,4	160	0,74	1230	4290	0,3685	⊙	⊙	⊙	⊙	⊙
	35,5	36,47	38,4	140	0,59	1330	4700	0,3626	⊙	⊙	⊙	⊙	⊙
	40	39,78	35,2	140	0,54	1420	4870	0,3635	⊙	⊙	⊙	⊙	⊙
	45	43,96	31,8	140	0,49	1420	4900	0,3585	⊙	⊙	⊙	⊙	⊙
	50	48,98	28,6	140	0,44	1420	4900	0,3539	⊙	⊙	⊙	⊙	⊙
56	52,07	26,9	110	0,32	1420	5150	0,3499	⊙	⊙	⊙	⊙	⊙	
60	62,78	22,3	120	0,29	1470	5400	0,3459	⊙	⊙	⊙	⊙	⊙	
<b>FRN 13</b> 3c	40	39,52	35,4	145	0,57	850	4762	0,2554	⊙	⊙	⊙	⊙	⊙
	50	48,04	29,1	155	0,50	950	4600	0,2512	⊙	⊙	⊙	⊙	⊙
	63	62,54	22,4	170	0,42	1070	4300	0,2474	⊙	⊙	⊙	⊙	⊙
	80	79,10	17,7	180	0,35	1140	4000	0,2451	⊙	⊙	⊙	⊙	⊙
	100	96,36	14,5	180	0,29	1200	4000	0,2437	⊙	⊙	⊙	⊙	⊙
	125	120,51	11,6	180	0,23	1250	4000	0,2426	⊙	⊙	⊙	⊙	⊙
	160	156,75	8,93	175	0,17	1300	4100	0,2416	⊙	⊙	⊙	⊙	⊙
	180	173,22	8,08	150	0,14	1340	4800	0,2414	⊙	⊙	⊙	⊙	⊙
	200	203,91	6,87	150	0,11	1320	4800	0,2326	⊙	⊙	⊙	⊙	⊙
	250	265,22	5,28	150	0,09	1350	4800	0,2322	⊙	⊙	⊙	⊙	⊙
	280	293,09	4,78	150	0,08	1360	4800	0,2321	⊙	⊙	⊙	⊙	⊙
	315	326,53	4,29	150	0,07	1360	4800	0,2320	⊙	⊙	⊙	⊙	⊙
400	418,50	3,35	120	0,04	1440	5300	0,2318	⊙	⊙	⊙	⊙	⊙	

2c &amp; 3c - Numero delle coppie di riduzione - Number of reduction stages - Anzahl der Getriebestufen | B\* = B5 &amp; B14

	Olio [ litri ] - Oil [ litres ] - Öl [ Liter ]						Peso-Weight Gewicht
	H1	H2	H3	H4	V1	V2	[ kg ]
FRN12	0.5	0.6	0.4	0.6	0.6	0.6	5.4
FRN13	0.5	0.4	0.3	0.3	0.6	0.4	5.5

## Getriebe - Gearboxes - Riduttori RN

1400 rpm

Getriebeauswahl - Speed Reducer Selection - Selezione Riduttore

	$i_n$	$i_r$	$n_2$ [rpm]	$M_2$ [Nm]	$P_1$ [kW]	$F_{r1}$ [N]	$F_{r2}$ [N]	$J_1 (x 10^{-4})$ [kgm <sup>2</sup> ]	71 B*	80 B*	90 B*	100 B*	112 B*
<b>FRN 22</b> 2c	6,3	5,76	243	190	5,1	2900	3200	2,5855	⊙	⊙	⊙	⊙	⊙
	7,1	7,37	190	215	4,6	2900	3450	2,1881	⊙	⊙	⊙	⊙	⊙
	8,0	7,80	179	220	4,4	2900	3530	2,2972	⊙	⊙	⊙	⊙	⊙
	9,0	9,07	154	240	4,1	2900	3690	1,9599	⊙	⊙	⊙	⊙	⊙
	10,0	9,98	140	230	3,6	3000	3850	2,0120	⊙	⊙	⊙	⊙	⊙
	11,2	11,33	124	260	3,6	2900	3890	1,7848	⊙	⊙	⊙	⊙	⊙
	12,5	12,29	114	230	2,9	3000	4140	1,8436	⊙	⊙	⊙	⊙	⊙
	14,0	14,51	96,5	300	3,2	3000	3720	1,6479	⊙	⊙	⊙	⊙	⊙
	16,0	15,36	91,2	230	2,3	3000	4480	1,7103	⊙	⊙	⊙	⊙	⊙
	18,0	17,87	78,4	310	2,7	3000	3590	1,5647	⊙	⊙	⊙	⊙	⊙
	20,0	19,66	71,2	230	1,8	3000	4810	1,6024	⊙	⊙	⊙	⊙	⊙
	22,4	22,67	61,8	310	2,1	3000	3800	1,4958	⊙	⊙	⊙	⊙	⊙
	25,0	24,21	57,8	240	1,5	3000	4970	1,5348	⊙	⊙	⊙	⊙	⊙
	28,0	29,32	47,8	265	1,4	3000	4770	1,4440	⊙	⊙	⊙	⊙	⊙
	31,5	30,71	45,6	240	1,2	3000	5180	1,4772	⊙	⊙	⊙	⊙	⊙
	35,5	34,52	40,6	220	0,99	3000	5420	1,4202	⊙	⊙	⊙	⊙	⊙
	40	39,72	35,2	240	0,94	3000	5380	1,4329	⊙	⊙	⊙	⊙	⊙
45	46,78	29,9	245	0,82	3000	5550	1,4122	⊙	⊙	⊙	⊙	⊙	
<b>FRN 23</b> 3c	50	51,19	27,3	245	0,75	3000	5650	1,4027	⊙	⊙	⊙	⊙	⊙
	63	62,66	22,3	250	0,62	3000	6040	1,3859	⊙	⊙	⊙	⊙	⊙
	40	36,34	38,5	250	1,07	-	5130	0,9994	⊙	⊙	⊙	⊙	⊙
	45	44,73	31,3	270	0,94	-	5070	0,9900	⊙	⊙	⊙	⊙	⊙
	56	55,91	25,0	310	0,86	1070	4970	0,9828	⊙	⊙	⊙	⊙	⊙
	71	71,57	19,6	310	0,68	1210	5100	0,9772	⊙	⊙	⊙	⊙	⊙
	80	79,01	17,7	140	0,28	1390	7160	0,9250	⊙	⊙	⊙	⊙	⊙
	90	88,14	15,9	310	0,55	1370	5200	0,9738	⊙	⊙	⊙	⊙	⊙
	100	101,07	13,9	180	0,28	1390	7190	0,9223	⊙	⊙	⊙	⊙	⊙
	112	111,82	12,5	310	0,43	1480	5200	0,9710	⊙	⊙	⊙	⊙	⊙
	125	124,39	11,3	220	0,28	1390	6700	0,9206	⊙	⊙	⊙	⊙	⊙
	140	144,62	9,7	265	0,29	1550	6100	0,9688	⊙	⊙	⊙	⊙	⊙
	160	155,49	9,0	260	0,26	1450	6200	0,9193	⊙	⊙	⊙	⊙	⊙
	180	186,37	7,5	200	0,17	1570	7000	0,9674	(⊙)	⊙	⊙	⊙	⊙
	200	199,03	7,0	260	0,20	1500	6200	0,9183	(⊙)	⊙	⊙	⊙	⊙
	224	228,12	6,1	170	0,12	1580	7400	0,9666	(⊙)	⊙	⊙	⊙	⊙
	250	245,13	5,7	260	0,17	1540	6200	0,9176	(⊙)	⊙	⊙	⊙	⊙
315	310,98	4,5	260	0,13	1560	6200	0,9170	(⊙)	⊙	⊙	⊙	⊙	
400	402,20	3,5	260	0,10	1570	6200	0,9166	(⊙)	⊙	⊙	⊙	⊙	
450	473,65	3,0	260	0,09	1570	6200	0,9164	(⊙)	⊙	⊙	⊙	⊙	
500	518,30	2,7	260	0,08	1580	6200	0,9163	(⊙)	⊙	⊙	⊙	⊙	
630	634,40	2,2	230	0,06	1580	6700	0,9161	(⊙)	⊙	⊙	⊙	⊙	

**2c & 3c** - Numero delle coppie di riduzione - Number of reduction stages - Anzahl der Getriebestufen | **B\*** = B5 & B14  
 (⊙) - Potenza max utilizzabile ≤ P<sub>1</sub> - Max, available power ≤ P<sub>1</sub> - Max. Leistung ≤ P<sub>1</sub>

	Olio [ litri ] - Oil [ litres ] - Öl [ Liter ]						Peso-Weight Gewicht [ kg ]
	H1	H2	H3	H4	V1	V2	
FRN22	0,7	0,8	0,5	0,8	0,7	0,7	8,6
FRN23	0,7	0,6	0,4	0,6	0,7	0,7	9,1



## RN Riduttori - Gearboxes - Getriebe

**Selezione Riduttore - Speed Reducer Selection - Getriebeauswahl**
**1400 rpm**

	$i_n$	$i_r$	$n_2$ [rpm]	$M_2$ [Nm]	$P_1$ [kW]	$F_{r1}$ [N]	$F_{r2}$ [N]	$J_1 (x 10^{-4})$ [kgm <sup>2</sup> ]	71 B*	80 B*	90 B*	100 B*	112 B*
<b>FRN 32</b> 2c	6,3	5,59	250	400	10,9	1780	4760	4,8684	⊙	⊙	⊙	⊙	⊙
	7,1	7,17	195	430	9,2	1890	5180	3,8232	⊙	⊙	⊙	⊙	⊙
	8,0	7,90	177	370	7,1	2100	5410	3,9288	⊙	⊙	⊙	⊙	⊙
	9,0	8,84	158	480	8,3	1790	5180	3,2176	⊙	⊙	⊙	⊙	⊙
	10,0	10,13	138	380	5,7	2170	5890	3,2515	⊙	⊙	⊙	⊙	⊙
	11,2	11,06	127	530	7,3	-	4550	2,7466	⊙	⊙	⊙	⊙	⊙
	12,5	12,49	112	380	4,6	2180	6330	2,8412	⊙	⊙	⊙	⊙	⊙
	14,0	14,18	98,8	540	5,8	1870	4700	2,3720	⊙	⊙	⊙	⊙	⊙
	16,0	15,63	89,6	390	3,8	2180	6830	2,5063	⊙	⊙	⊙	⊙	⊙
	18,0	18,84	74,3	550	4,5	2020	4860	2,0717	⊙	⊙	⊙	⊙	⊙
	20,0	20,03	69,9	390	3,0	2180	7400	2,2256	⊙	⊙	⊙	⊙	⊙
	22,4	22,18	63,1	550	3,8	-	5000	1,9456	⊙	⊙	⊙	⊙	⊙
	25,0	26,62	52,6	400	2,3	2180	7750	1,9888	⊙	⊙	⊙	⊙	⊙
	28,0	28,93	48,4	540	2,9	1610	5550	1,7952	⊙	⊙	⊙	⊙	⊙
	31,5	31,33	44,7	400	1,9	2180	7920	1,8858	⊙	⊙	⊙	⊙	⊙
	35,5	34,50	40,6	450	2,0	2020	7320	1,7221	⊙	⊙	⊙	⊙	⊙
	40	40,87	34,3	420	1,6	2180	8250	1,7600	⊙	⊙	⊙	⊙	⊙
	45	47,50	29,5	320	1,0	2180	9440	1,6310	⊙	⊙	⊙	⊙	⊙
50	48,74	28,7	420	1,3	2180	8530	1,6974	⊙	⊙	⊙	⊙	⊙	
56	53,75	26,0	420	1,2	2180	8640	1,6689	⊙	⊙	⊙	⊙	⊙	
63	67,10	20,9	420	1,0	2180	9030	1,6180	⊙	⊙	⊙	⊙	⊙	
<b>FRN 33</b> 3c	40	35,86	39,0	490	2,1	1610	6840	1,2294	⊙	⊙	⊙	⊙	⊙
	45	44,20	31,7	550	1,9	-	5900	1,2052	⊙	⊙	⊙	⊙	⊙
	56	55,31	25,3	580	1,6	1640	5500	1,1864	⊙	⊙	⊙	⊙	⊙
	71	70,88	19,8	580	1,3	1950	5500	1,1714	⊙	⊙	⊙	⊙	⊙
	80	80,62	17,4	265	0,51	2160	10880	1,0679	⊙	⊙	⊙	⊙	⊙
	90	94,22	14,9	580	0,96	2160	5500	1,1594	⊙	⊙	⊙	⊙	⊙
	100	103,34	13,5	340	0,51	2170	10730	1,0614	⊙	⊙	⊙	⊙	⊙
	112	110,89	12,6	580	0,82	2230	5500	1,1543	⊙	⊙	⊙	⊙	⊙
	125	127,37	11,0	420	0,51	2160	9700	1,0575	⊙	⊙	⊙	⊙	⊙
	140	144,64	9,7	580	0,63	2300	5500	1,1483	⊙	⊙	⊙	⊙	⊙
	160	159,41	8,8	430	0,42	2240	9400	1,0542	⊙	⊙	⊙	⊙	⊙
	180	172,50	8,1	480	0,43	2300	8600	1,1454	⊙	⊙	⊙	⊙	⊙
	200	204,26	6,9	430	0,33	2300	9400	1,0515	⊙	⊙	⊙	⊙	⊙
	224	237,50	5,9	320	0,21	2300	11100	1,1417	⊙	⊙	⊙	⊙	⊙
	280	271,53	5,2	430	0,25	2300	9400	1,0493	⊙	⊙	⊙	⊙	⊙
	315	319,58	4,4	430	0,21	2300	9400	1,0483	(⊙)	⊙	⊙	⊙	⊙
	400	416,85	3,4	430	0,16	2300	9400	1,0471	(⊙)	⊙	⊙	⊙	⊙
500	497,13	2,8	430	0,13	2300	9400	1,0465	(⊙)	⊙	⊙	⊙	⊙	
560	548,22	2,6	430	0,12	2300	9400	1,0462	(⊙)	⊙	⊙	⊙	⊙	
710	684,45	2,1	430	0,10	2300	9400	1,0457	(⊙)	⊙	⊙	⊙	⊙	

**2c & 3c** - Numero delle coppie di riduzione - Number of reduction stages - Anzahl der Getriebestufen | **B\*** = B5 & B14  
 (⊙) - Potenza max utilizzabile ≤ P<sub>1</sub> - Max, available power ≤ P<sub>1</sub> - Max, Leistung ≤ P<sub>1</sub>

	Olio [ litri ] - Oil [ litres ] - Öl [ Liter ]						Peso-Weight Gewicht
	H1	H2	H3	H4	V1	V2	[ kg ]
FRN32	1,1	1,3	0,8	1,3	1,2	1,2	12,5
FRN33	1,2	1,0	0,6	1,0	1,2	1,0	13,0

## Getriebe - Gearboxes - Riduttori RN

1400 rpm

Getriebeauswahl - Speed Reducer Selection - Selezione Riduttore

	$i_n$	$i_r$	$n_2$ [rpm]	$M_2$ [Nm]	$P_1$ [kW]	$F_{r1}$ [N]	$F_{r2}$ [N]	$J_1 (x 10^{-4})$ [kgm <sup>2</sup> ]	71 B5	80 B*	90 B5	100 B*	112 B*
<b>FRN 42</b> 2c	6,3	5,74	244	680	18	-	5030	13,0943	⊙	⊙	⊙	⊙	⊙
	7,1	7,26	193	790	17	-	5190	10,7969	⊙	⊙	⊙	⊙	⊙
	8,0	7,59	185	690	14	2020	5680	11,2674	⊙	⊙	⊙	⊙	⊙
	9,0	9,08	154	890	15	-	5660	9,2579	⊙	⊙	⊙	⊙	⊙
	10,0	9,60	146	690	11	2400	6200	9,6555	⊙	⊙	⊙	⊙	⊙
	11,2	11,55	121	910	12	-	6170	8,0995	⊙	⊙	⊙	⊙	⊙
	12,5	12,00	117	700	9	2610	6720	8,5274	⊙	⊙	⊙	⊙	⊙
	14,0	14,09	99,3	920	10	2440	6810	7,4107	⊙	⊙	⊙	⊙	⊙
	16,0	15,27	91,7	710	7,1	2720	7330	7,6485	⊙	⊙	⊙	⊙	⊙
	18,0	17,59	79,6	930	8,1	-	7410	6,8426	⊙	⊙	⊙	⊙	⊙
	22,4	22,69	61,7	940	6,3	2090	8160	6,4129	⊙	⊙	⊙	⊙	⊙
	28,0	28,28	49,5	890	4,8	2450	8920	6,1008	⊙	⊙	⊙	⊙	⊙
	31,5	30,00	46,7	730	3,7	2850	9290	6,2602	⊙	⊙	⊙	⊙	
	35,5	37,39	37,4	740	3,0	2860	10030	6,0256	⊙	⊙	⊙	⊙	
	40	38,12	36,7	650	2,6	2800	10140	5,8382	⊙	⊙	⊙	⊙	
	45	45,27	30,9	750	2,5	2900	10720	5,8675	⊙	⊙	⊙	⊙	
50	50,40	27,8	750	2,3	2870	11110	5,7968	⊙	⊙	⊙	⊙		
56	56,67	24,7	700	1,9	2880	11600	5,7318	⊙	⊙	⊙			
<b>FRN 43</b> 3c	40	34,07	41,1	730	3,3	-	9670	4,3102	⊙	⊙	⊙	⊙	
	45	42,59	32,9	910	3,3	-	10030	4,2058	⊙	⊙	⊙	⊙	
	56	54,21	25,8	980	2,8	2030	9830	4,1359	⊙	⊙	⊙	⊙	
	63	66,13	21,2	990	2,3	2270	10110	4,0833	⊙	⊙	⊙	⊙	
	71	70,82	19,8	410	0,9	3020	12640	4,0520	⊙	⊙			
	80	82,52	17,0	1000	1,9	2720	10510	3,7956	⊙	⊙	⊙		
	90	89,60	15,6	510	0,9	3020	13650	4,0262	⊙	⊙			
	100	106,48	13,1	1010	1,5	3060	10930	3,7770	⊙	⊙	⊙		
	140	132,69	10,6	950	1,1	3270	12260	4,0051	⊙	⊙	⊙		
	160	160,69	8,7	760	0,74	3370	14590	3,9942	⊙	⊙			
	180	173,90	8,1	800	0,72	3170	14570	3,9843	⊙	⊙			
	200	201,13	7,0	550	0,43	3370	16680	3,7478	⊙				
	224	217,00	6,5	800	0,57	3300	15210	3,9773	⊙	⊙			
	280	280,00	5,0	800	0,45	3370	16030	3,7425	⊙				
	355	348,92	4,01	800	0,36	3370	16500	3,7381	⊙				
	450	422,55	3,31	800	0,30	3370	16500	3,7354	⊙				
500	470,40	2,98	800	0,27	3370	16500	3,7336	⊙					
560	528,89	2,65	800	0,24	3370	17000	3,7328	⊙					

**2c & 3c** - Numero delle coppie di riduzione - Number of reduction stages - Anzahl der Getriebestufen | **B\*** = B5 & B14  
 (⊙) - Potenza max utilizzabile ≤ P<sub>1</sub> - Max, available power ≤ P<sub>1</sub> - Max, Leistung ≤ P<sub>1</sub>

	Olio [ litri ] - Oil [ litres ] - Öl [ Liter ]						Peso-Weight Gewicht [ kg ]
	H1	H2	H3	H4	V1	V2	
FRN42	2,8	1,8	1,2	1,8	2,7	2,7	33,5
FRN43	2,5	1,5	0,9	1,5	2,2	1,9	36,0

## RN Riduttori - Gearboxes - Getriebe

Selezione Riduttore - Speed Reducer Selection - Getriebeauswahl

1400 rpm

	$i_n$	$i_r$	$n_2$ [rpm]	$M_2$ [Nm]	$P_1$ [kW]	$F_{r1}$ [N]	$F_{r2}$ [N]	$J_1 (x 10^{-4})$ [kgm <sup>2</sup> ]	80 90 B5	100 112 B5	132 B*	160 B*	180 B*
<b>FRN 52</b> 2c	6,3	5,64	248	1100	30	-	7550	37,6347	⊙	⊙	⊙	⊙	⊙
	7,1	7,46	188	1260	26	-	8250	31,2885	⊙	⊙	⊙	⊙	⊙
	8,0	7,66	183	1140	23	-	8410	31,9539	⊙	⊙	⊙	⊙	⊙
	9,0	9,46	148	1400	23	-	8900	27,6749	⊙	⊙	⊙	⊙	⊙
	10,0	10,13	138	1150	17	-	9280	28,0395	⊙	⊙	⊙	⊙	⊙
	11,2	11,45	122	1550	21	-	8400	25,5151	⊙	⊙	⊙	⊙	⊙
	12,5	12,85	109	1170	14	-	10080	25,6545	⊙	⊙	⊙	⊙	
	14,0	14,12	99,2	1610	17	-	8470	23,7029	⊙	⊙	⊙	⊙	⊙
	16,0	15,56	90,0	1180	12	-	10780	24,1384	⊙	⊙	⊙	⊙	
	18,0	17,85	78,4	1630	14	-	8680	22,1741	⊙	⊙	⊙	⊙	
	20,0	19,19	73,0	1190	10	-	11580	22,7969	⊙	⊙	⊙		
	22,4	23,45	59,7	1650	11	-	8020	20,8963	⊙	⊙	⊙		
	25,0	24,26	57,7	1200	7,6	-	12560	21,6073	⊙	⊙	⊙		
	28,0	27,55	50,8	1670	9,3	-	8090	20,3546	⊙	⊙	⊙		
	31,5	30,02	46,6	1590	8,1	-	9610	20,1029	⊙	⊙	⊙		
	35,5	36,31	38,6	1300	5,5	-	13530	19,6654	⊙	⊙	⊙		
	40	40,79	34,3	1250	4,7	3370	14620	19,9025	⊙	⊙			
	45	45,38	30,8	1100	3,7	-	15630	19,2544	⊙	⊙			
50	49,33	28,4	1300	4,0	3410	15030	19,5092	⊙	⊙				
63	61,67	22,7	1300	3,2	3440	15530	19,1667	⊙	⊙				
<b>FRN 53</b> 3c	40	37,28	37,6	1650	6,9	-	9220	13,8553	⊙	⊙	⊙		
	45	47,28	29,6	1710	5,6	-	8610	13,7108	⊙	⊙	⊙		
	56	57,27	24,4	1750	4,8	3470	8800	13,6244	⊙	⊙			
	71	70,60	19,8	1750	3,9	3930	9010	13,5519	⊙	⊙			
	90	89,26	15,7	1770	3,1	4280	8500	13,4907	⊙	⊙			
	100	95,68	14,6	1160	1,9	4190	17820	12,7382	⊙				
	112	117,24	11,9	1790	2,4	4560	7200	13,4396	⊙	⊙			
	125	121,33	11,5	1310	1,7	4350	17330	12,7114	⊙				
	140	137,77	10,2	1800	2,0	4680	7200	13,4179	⊙				
	160	150,12	9,33	1700	1,8	4790	12400	13,4079	⊙				
	180	181,54	7,71	1360	1,2	4960	18220	13,3896	⊙				
	224	229,08	6,11	1350	0,92	4830	19100	12,6660	⊙				
	315	300,91	4,65	1350	0,70	4950	19100	12,6544	⊙				
	355	353,60	3,96	1350	0,60	5000	19100	12,6493	⊙				
	400	385,28	3,63	1350	0,55	5030	19100	12,6469	⊙				
450	465,93	3,00	1350	0,45	5070	19100	12,6425	(⊙)					
560	582,41	2,40	1350	0,36	5110	19100	12,6387	(⊙)					

**2c & 3c** - Numero delle coppie di riduzione - Number of reduction stages - Anzahl der Getriebestufen | **B\*** = B5 & B14  
 (⊙) - Potenza max utilizzabile ≤ P<sub>1</sub> - Max, available power ≤ P<sub>1</sub> - Max, Leistung ≤ P<sub>1</sub>

	Olio [ litri ] - Oil [ litres ] - Öl [ Liter ]						Peso-Weight Gewicht
	H1	H2	H3	H4	V1	V2	[ kg ]
FRN52	5,1	3,2	2,1	3,2	4,9	4,9	62
FRN53	5,0	2,8	1,6	2,8	4,0	3,4	67

Getriebe - Gearboxes - Riduttori RN

1400 rpm Getriebeauswahl - Speed Reducer Selection - Selezione Riduttore

	$i_n$	$i_r$	$n_2$ [rpm]	$M_2$ [Nm]	$P_1$ [kW]	$F_{r1}$ [N]	$F_{r2}$ [N]	$J_1 (x 10^{-4})$ [kgm <sup>2</sup> ]	80 90 B5	100 112 B5	132 B*	160 B*	180 B*
<b>FRN 62</b> 2c	6,3	5,77	250	2200	60	-	10060	84,0612	⊙	⊙	⊙	⊙	⊙
	7,1	7,39	189	2600	54	-	9540	68,0211	⊙	⊙	⊙	⊙	⊙
	8,0	7,97	176	2200	42	-	11380	68,6806	⊙	⊙	⊙	⊙	⊙
	9,0	9,38	149	2900	47	-	9030	56,8499	⊙	⊙	⊙	⊙	⊙
	10,0	10,54	133	2200	32	-	12550	58,6662	⊙	⊙	⊙	⊙	⊙
	11,2	11,36	123	3100	42	-	5620	50,1639	⊙	⊙	⊙	⊙	⊙
	14,0	14,00	100	3160	35	-	5450	44,5468	⊙	⊙	⊙	⊙	⊙
	16,0	16,19	86,4	2250	21	3800	11630	46,1997	⊙	⊙	⊙	⊙	⊙
	18,0	17,70	79,1	3200	28	-	3100	39,8027	⊙	⊙	⊙	⊙	⊙
	20,0	19,96	70,1	2270	17	4020	15790	41,9382	⊙	⊙	⊙	⊙	⊙
	22,4	23,25	60,2	3250	21	-	8000	35,8331	⊙	⊙	⊙	⊙	⊙
	25,0	25,24	55,5	3000	18	4200	16780	38,1707	⊙	⊙	⊙	⊙	⊙
	28,0	27,69	50,6	3270	18	-	6000	34,0539	⊙	⊙	⊙	⊙	⊙
	31,5	30,38	46,1	3105	16	-	7160	33,2259	⊙	⊙	⊙	⊙	⊙
	35,5	37,35	37,5	2515	10	-	16090	31,7360	⊙	⊙	⊙	⊙	
	40	39,49	35,5	3245	13	4440	18170	33,3872	⊙	⊙	⊙	⊙	
	45	43,31	32,3	2360	8,3	4470	18380	32,6717	⊙	⊙	⊙		
	50	53,26	26,3	2380	6,8	4520	18970	31,3694	⊙	⊙	⊙		
56	59,89	23,4	2400	6,1	4540	19310	30,7868	⊙	⊙	⊙			
<b>FRN 63</b> 3c	40	38,20	36,7	3250	13	-	7350	22,6869	⊙	⊙	⊙	⊙	
	50	48,44	28,9	3400	11	-	7670	22,2684	⊙	⊙	⊙	⊙	
	56	58,68	23,9	3400	9,0	-	7800	22,0179	⊙	⊙	⊙		
	71	72,33	19,4	3400	7,3	3670	7800	21,8075	⊙	⊙	⊙		
	80	79,72	17,6	1780	3,5	2870	25090	19,9592	⊙	⊙			
	90	91,45	15,3	3400	5,8	3030	7800	21,6298	⊙	⊙	⊙		
	100	105,42	13,3	2350	3,5	2870	22430	19,8591	⊙	⊙			
	125	120,13	11,7	3400	4,4	3840	7800	21,4811	⊙	⊙			
	140	143,08	9,78	3400	3,7	4160	7800	21,4145	⊙	⊙			
	160	156,94	8,92	3300	3,3	4330	7900	21,3834	⊙	⊙			
	200	192,98	7,25	2700	2,2	4720	21200	21,3276	⊙	⊙			
	224	217,00	6,45	2300	1,7	4880	26700	21,3029	⊙				
	250	252,39	5,55	2600	1,6	4490	22500	19,6541	⊙				
	315	331,53	4,22	2600	1,2	4720	22500	19,6213	⊙				
	400	394,87	3,55	2600	1,0	4820	22500	19,6063	⊙				
	450	433,13	3,23	2600	0,94	4870	22500	19,5991	⊙				
500	532,58	2,63	2600	0,76	4960	22500	19,5861	⊙					
560	598,89	2,34	2600	0,68	4990	22500	19,5803	⊙					

2c & 3c - Numero delle coppie di riduzione - Number of reduction stages - Anzahl der Getriebestufen | B\* = B5 & B14

	Olio [ litri ] - Oil [ litres ] - Öl [ Liter ]						Peso-Weight Gewicht
	H1	H2	H3	H4	V1	V2	[ kg ]
FRN62	9,2	5,8	3,8	5,8	8,8	8,8	109
FRN63	9,0	5,0	2,9	5,0	7,2	6,1	116

## RN Riduttori - Gearboxes - Getriebe

Selezione Motoriduttore - Geared Motor Selection - Getriebemotorauswahl

1400 rpm

P <sub>1</sub> [kW]	i <sub>n</sub>	i <sub>r</sub>	n <sub>2</sub> [rpm]	M <sub>2</sub> [Nm]	FS	Tipo - Size - Größe	F <sub>r2</sub> [N]	MRN [kg]	FRN [kg]	J <sub>m</sub> × 10 <sup>-4</sup>	J <sub>1</sub> × 10 <sup>-4</sup>
0,06	7,1	6,59	212	2,59	> 3,0	MRN 12	3350	8,5	6,0	1,50	0,8414
	8,0	7,95	176	3,12	> 3,0	MRN 12	3470	8,5	6,0	1,50	0,7600
	9,0	8,32	168	3,23	> 3,0	MRN 12	3580	8,5	6,0	1,50	0,6786
	10,0	10,11	138	3,91	> 3,0	MRN 12	3490	8,5	6,0	1,50	0,5849
	12,5	12,19	115	4,88	> 3,0	MRN 12	3470	8,5	6,0	1,50	0,5416
	14,0	13,17	106	5,21	> 3,0	MRN 12	3450	8,5	6,0	1,50	0,4982
	16,0	15,87	88,2	6,46	> 3,0	MRN 12	3450	8,5	6,0	1,50	0,4722
	18,0	16,65	84,1	6,60	> 3,0	MRN 12	3560	8,5	6,0	1,50	0,4462
	20,0	20,29	69	7,85	> 3,0	MRN 12	3710	8,5	6,0	1,50	0,4149
	22,4	25,37	55,2	10,20	> 3,0	MRN 12	3850	8,5	6,0	1,50	0,3892
	31,5	30,59	45,8	12,00	> 3,0	MRN 12	4070	8,5	6,0	1,50	0,3789
	33,0	33	42,4	12,97	> 3,0	MRN 12	4290	8,5	6,0	1,50	0,3685
	35,5	36,47	38,4	14,24	> 3,0	MRN 12	4700	8,5	6,0	1,50	0,3626
	40,0	39,78	35,2	15,56	> 3,0	MRN 12	4870	8,5	6,0	1,50	0,3635
		39,52	35,4	15,26	> 3,0	MRN 13	4762	8,3	5,8	1,50	0,2554
	45,0	43,96	31,8	17,14	> 3,0	MRN 12	4900	8,5	6,0	1,50	0,3585
	50,0	48,98	28,6	19,09	> 3,0	MRN 12	4900	8,5	6,0	1,50	0,3539
		48,04	29,1	18,60	> 3,0	MRN 13	4600	8,3	5,8	1,50	0,2512
	56,0	52,07	26,9	20,63	> 3,0	MRN 12	5150	8,5	6,0	1,50	0,3499
	60,0	62,78	22,3	24,83	> 3,0	MRN 12	5400	8,5	6,0	1,50	0,3459
	63,0	62,54	22,4	24,29	> 3,0	MRN 13	4300	8,3	5,8	1,50	0,2474
	80,0	79,1	17,7	30,86	> 3,0	MRN 13	4000	8,3	5,8	1,50	0,2451
	100,0	96,36	14,5	37,24	> 3,0	MRN 13	4000	8,3	5,8	1,50	0,2437
	125,0	120,51	11,6	46,96	> 3,0	MRN 13	4000	8,3	5,8	1,50	0,2426
	160,0	156,75	8,93	61,76	2,8	MRN 13	4100	8,3	5,8	1,50	0,2416
	180,0	173,22	8,08	64,29	2,3	MRN 13	4800	8,3	5,8	1,50	0,2414
	200,0	203,91	6,87	81,82	1,8	MRN 13	4800	8,3	5,8	1,50	0,2326
	250,0	265,22	5,28	100,00	1,5	MRN 13	4800	8,3	5,8	1,50	0,2322
	280,0	293,09	4,78	112,50	1,3	MRN 13	4800	8,3	5,8	1,50	0,2321
	315,0	326,53	4,29	128,57	1,2	MRN 13	4800	8,3	5,8	1,50	0,2320
	0,09	7,1	6,59	212	3,88	> 3,0	MRN 12	3350	8,6	6,0	2,00
8,0		7,95	176	4,68	> 3,0	MRN 12	3470	8,6	6,0	2,00	0,7600
9,0		8,32	168	4,85	> 3,0	MRN 12	3580	8,6	6,0	2,00	0,6786
10,0		10,11	138	5,87	> 3,0	MRN 12	3490	8,6	6,0	2,00	0,5849
12,5		12,19	115	7,31	> 3,0	MRN 12	3470	8,6	6,0	2,00	0,5416
14,0		13,17	106	7,82	> 3,0	MRN 12	3450	8,6	6,0	2,00	0,4982
16,0		15,87	88,2	9,69	> 3,0	MRN 12	3450	8,6	6,0	2,00	0,4722
18,0		16,65	84,1	9,90	> 3,0	MRN 12	3560	8,6	6,0	2,00	0,4462
20,0		20,29	69	11,77	> 3,0	MRN 12	3710	8,6	6,0	2,00	0,4149
22,4		25,37	55,2	15,30	> 3,0	MRN 12	3850	8,6	6,0	2,00	0,3892
31,5		30,59	45,8	18,00	> 3,0	MRN 12	4070	8,6	6,0	2,00	0,3789
33,0		33	42,4	19,46	> 3,0	MRN 12	4290	8,6	6,0	2,00	0,3685
35,5		36,47	38,4	21,36	> 3,0	MRN 12	4700	8,6	6,0	2,00	0,3626
40,0		39,78	35,2	23,33	> 3,0	MRN 12	4870	8,6	6,0	2,00	0,3635
		39,52	35,4	22,89	> 3,0	MRN 13	4762	8,4	5,8	2,00	0,2554
45,0		43,96	31,8	25,71	> 3,0	MRN 12	4900	8,6	6,0	2,00	0,3585
50,0		48,98	28,6	28,64	> 3,0	MRN 12	4900	8,6	6,0	2,00	0,3539
		48,04	29,1	27,90	> 3,0	MRN 13	4600	8,4	5,8	2,00	0,2512
56,0		52,07	26,9	30,94	> 3,0	MRN 12	5150	8,6	6,0	2,00	0,3499
60,0		62,78	22,3	37,24	> 3,0	MRN 12	5400	8,6	6,0	2,00	0,3459



## Getriebe - Gearboxes - Riduttori RN

1400 rpm

Selezione Motoriduttore - Geared Motor Selection - Getriebemotorauswahl

P <sub>1</sub> [kW]	i <sub>n</sub>	i <sub>r</sub>	N <sub>2</sub> [rpm]	M <sub>2</sub> [Nm]	FS	Tipo - Size - Größe	F <sub>r2</sub> [N]	MRN [kg]	FRN [kg]	J <sub>m</sub> × 10 <sup>-4</sup>	J <sub>1</sub> × 10 <sup>-4</sup>
0,09	63,0	62,54	22,4	36,43	> 3,0	MRN 13	4300	8,4	5,8	2,00	0,2474
	80,0	79,1	17,7	46,29	> 3,0	MRN 13	4000	8,4	5,8	2,00	0,2451
	100,0	96,36	14,5	55,86	> 3,0	MRN 13	4000	8,4	5,8	2,00	0,2437
	125,0	120,51	11,6	70,43	2,6	MRN 13	4000	8,4	5,8	2,00	0,2426
	160,0	156,75	8,93	92,65	1,9	MRN 13	4100	8,4	5,8	2,00	0,2416
	180,0	173,22	8,08	96,43	1,6	MRN 13	4800	8,4	5,8	2,00	0,2414
	200,0	203,91	6,87	122,73	1,2	MRN 13	4800	8,4	5,8	2,00	0,2326
	250,0	265,22	5,28	150,00	1,0	MRN 13	4800	8,4	5,8	2,00	0,2322
	280,0	293,09	4,78	168,75	0,9	MRN 13	4800	8,4	5,8	2,00	0,2321
	315,0	326,53	4,29	192,86	0,8	MRN 13	4800	8,4	5,8	2,00	0,2320
0,12	7,1	6,59	212	5,60	> 3,0	MRN 12	3350	9,7	6,0	2,80	0,8414
	8,0	7,95	176	6,76	> 3,0	MRN 12	3470	9,7	6,0	2,80	0,7600
	9,0	8,32	168	7,00	> 3,0	MRN 12	3580	9,7	6,0	2,80	0,6786
	10,0	10,11	138	8,48	> 3,0	MRN 12	3490	9,7	6,0	2,80	0,5849
	12,5	12,19	115	10,56	> 3,0	MRN 12	3470	9,7	6,0	2,80	0,5416
	14,0	13,17	106	11,29	> 3,0	MRN 12	3450	9,7	6,0	2,80	0,4982
	16,0	15,87	88,2	14,00	> 3,0	MRN 12	3450	9,7	6,0	2,80	0,4722
	18,0	16,65	84,1	14,30	> 3,0	MRN 12	3560	9,7	6,0	2,80	0,4462
	20,0	20,29	69	17,00	> 3,0	MRN 12	3710	9,7	6,0	2,80	0,4149
	22,4	25,37	55,2	22,10	> 3,0	MRN 12	3850	9,7	6,0	2,80	0,3892
	31,5	30,59	45,8	26,00	> 3,0	MRN 12	4070	9,7	6,0	2,80	0,3789
	33,0	33	42,4	28,11	> 3,0	MRN 12	4290	9,7	6,0	2,80	0,3685
	35,5	36,47	38,4	30,85	> 3,0	MRN 12	4700	9,7	6,0	2,80	0,3626
	40,0	39,78	35,2	33,70	> 3,0	MRN 12	4870	9,7	6,0	2,80	0,3635
		39,52	35,4	33,07	> 3,0	MRN 13	4762	9,5	5,8	2,80	0,2554
	45,0	43,96	31,8	37,14	> 3,0	MRN 12	4900	9,7	6,0	2,80	0,3585
	50,0	48,98	28,6	41,36	> 3,0	MRN 12	4900	9,7	6,0	2,80	0,3539
		48,04	29,1	40,30	> 3,0	MRN 13	4600	9,5	5,8	2,80	0,2512
	56,0	52,07	26,9	44,69	2,5	MRN 12	5150	9,7	6,0	2,80	0,3499
	60,0	62,78	22,3	53,79	2,2	MRN 12	5400	9,7	6,0	2,80	0,3459
63,0	62,54	22,4	52,62	3,2	MRN 13	4300	9,5	5,8	2,80	0,2474	
80,0	79,1	17,7	66,86	2,7	MRN 13	4000	9,5	5,8	2,80	0,2451	
100,0	96,36	14,5	80,69	2,2	MRN 13	4000	9,5	5,8	2,80	0,2437	
125,0	120,51	11,6	101,74	1,8	MRN 13	4000	9,5	5,8	2,80	0,2426	
160,0	156,75	8,93	133,82	1,3	MRN 13	4100	9,5	5,8	2,80	0,2416	
180,0	173,22	8,08	139,29	1,1	MRN 13	4800	9,5	5,8	2,80	0,2414	
0,18	7,1	6,59	212	7,76	> 3,0	MRN 12	3350	10,3	6,0	4,00	0,8414
	8,0	7,95	176	9,36	> 3,0	MRN 12	3470	10,3	6,0	4,00	0,7600
	9,0	8,32	168	9,69	> 3,0	MRN 12	3580	10,3	6,0	4,00	0,6786
	10,0	10,11	138	11,74	> 3,0	MRN 12	3490	10,3	6,0	4,00	0,5849
	12,5	12,19	115	14,63	> 3,0	MRN 12	3470	10,3	6,0	4,00	0,5416
	14,0	13,17	106	15,63	> 3,0	MRN 12	3450	10,3	6,0	4,00	0,4982
	16,0	15,87	88,2	19,38	> 3,0	MRN 12	3450	10,3	6,0	4,00	0,4722
	18,0	16,65	84,1	19,80	> 3,0	MRN 12	3560	10,3	6,0	4,00	0,4462
	20,0	20,29	69	23,54	> 3,0	MRN 12	3710	10,3	6,0	4,00	0,4149
	22,4	25,37	55,2	30,60	> 3,0	MRN 12	3850	10,3	6,0	4,00	0,3892
	31,5	30,59	45,8	36,00	> 3,0	MRN 12	4070	10,3	6,0	4,00	0,3789
	33,0	33	42,4	38,92	> 3,0	MRN 12	4290	10,3	6,0	4,00	0,3685
	35,5	36,47	38,4	42,71	> 3,0	MRN 12	4700	10,3	6,0	4,00	0,3626
	40,0	39,78	35,2	46,67	3,0	MRN 12	4870	10,3	6,0	4,00	0,3635

## RN Riduttori - Gearboxes - Getriebe

Selezione Motoriduttore - Geared Motor Selection - Getriebemotorauswahl

1400 rpm

P <sub>1</sub> [kW]	i <sub>n</sub>	i <sub>r</sub>	N <sub>2</sub> [rpm]	M <sub>2</sub> [Nm]	FS	Tipo - Size - Größe	F <sub>r2</sub> [N]	MRN [kg]	FRN [kg]	J <sub>m</sub> × 10 <sup>-4</sup>	J <sub>1</sub> × 10 <sup>-4</sup>
0,18	40,0	39,52	35,4	45,79	> 3,0	MRN 13	4762	10,1	5,8	4,00	0,2554
	45,0	43,96	31,8	51,43	2,7	MRN 12	4900	10,3	6,0	4,00	0,3585
	50,0	48,98	28,6	57,27	2,4	MRN 12	4900	10,3	6,0	4,00	0,3539
	50,0	48,04	29,1	55,80	2,8	MRN 13	4600	10,1	5,8	4,00	0,2512
	56,0	52,07	26,9	61,88	1,8	MRN 12	5150	10,3	6,0	4,00	0,3499
	60,0	62,78	22,3	74,48	1,6	MRN 12	5400	10,3	6,0	4,00	0,3459
	63,0	62,54	22,4	72,86	2,3	MRN 13	4300	10,1	5,8	4,00	0,2474
	80,0	79,1	17,7	92,57	1,9	MRN 13	4000	10,1	5,8	4,00	0,2451
	100,0	96,36	14,5	111,72	1,6	MRN 13	4000	10,1	5,8	4,00	0,2437
	125,0	120,51	11,6	140,87	1,3	MRN 13	4000	10,1	5,8	4,00	0,2426
	160,0	156,75	8,93	185,29	0,9	MRN 13	4100	10,1	5,8	4,00	0,2416
	180,0	173,22	8,08	192,86	0,8	MRN 13	4800	10,1	5,8	4,00	0,2414
0,25	6,3	5,76	243	9,31	> 3,0	MRN 22	3200	15,2	9,4	5,00	2,5855
		5,59	250	9,17	> 3,0	MRN 32	4760	19,6	13,8	5,00	4,8684
		5,74	244	9,39	> 3,0	MRN 42	5030	41,1	35,3	5,00	13,0943
	7,1	6,59	212	10,78	> 3,0	MRN 12	3350	11,8	6,0	5,00	0,8414
		7,37	190	11,68	> 3,0	MRN 22	3450	15,2	9,4	5,00	2,1881
		7,17	195	11,68	> 3,0	MRN 32	5180	19,6	13,8	5,00	3,8232
	8,0	7,26	193	11,90	> 3,0	MRN 42	5190	41,1	35,3	5,00	10,7969
		7,95	176	13,00	> 3,0	MRN 12	3470	11,8	6,0	5,00	0,7600
		7,8	179	12,50	> 3,0	MRN 22	3530	15,2	9,4	5,00	2,2972
	9,0	7,9	177	13,03	> 3,0	MRN 32	5410	19,6	13,8	5,00	3,9288
		7,59	185	12,41	> 3,0	MRN 42	5680	41,1	35,3	5,00	11,2674
		8,32	168	13,46	> 3,0	MRN 12	3580	11,8	6,0	5,00	0,6786
		9,07	154	14,63	> 3,0	MRN 22	3690	15,2	9,4	5,00	1,9599
		8,84	158	14,46	> 3,0	MRN 32	5180	19,6	13,8	5,00	3,2176
		9,08	154	14,83	> 3,0	MRN 42	5660	41,1	35,3	5,00	9,2579
	10,0	10,11	138	16,30	> 3,0	MRN 12	3490	11,8	6,0	5,00	0,5849
		9,98	140	15,97	> 3,0	MRN 22	3850	15,2	9,4	5,00	2,0120
		10,13	138	16,67	> 3,0	MRN 32	5890	19,6	13,8	5,00	3,2515
	11,2	9,6	146	15,68	> 3,0	MRN 42	6200	41,1	35,3	5,00	9,6555
		11,33	124	18,06	> 3,0	MRN 22	3890	15,2	9,4	5,00	1,7848
		11,06	127	18,15	> 3,0	MRN 32	4550	19,6	13,8	5,00	2,7466
	12,5	11,55	121	18,96	> 3,0	MRN 42	6170	41,1	35,3	5,00	8,0995
		12,19	115	20,31	> 3,0	MRN 12	3470	11,8	6,0	5,00	0,5416
		12,29	114	19,83	> 3,0	MRN 22	4140	15,2	9,4	5,00	1,8436
		12,49	112	20,65	> 3,0	MRN 32	6330	19,6	13,8	5,00	2,8412
	14,0	12	117	19,66	> 3,0	MRN 42	6720	41,1	35,3	5,00	8,5274
		13,17	106	21,71	> 3,0	MRN 12	3450	11,8	6,0	5,00	0,4982
		14,51	96,5	23,44	> 3,0	MRN 22	3720	15,2	9,4	5,00	1,6479
		14,18	98,8	23,28	> 3,0	MRN 32	4700	19,6	13,8	5,00	2,3720
	16,0	14,09	99,3	23,00	> 3,0	MRN 42	6810	41,1	35,3	5,00	7,4107
15,87		88,2	26,92	> 3,0	MRN 12	3450	11,8	6,0	5,00	0,4722	
15,36		91,2	25,00	> 3,0	MRN 22	4480	15,2	9,4	5,00	1,7103	
15,63		89,6	25,66	> 3,0	MRN 32	6830	19,6	13,8	5,00	2,5063	
18,0	15,27	91,7	25,00	> 3,0	MRN 42	7330	41,1	35,3	5,00	7,6485	
	16,65	84,1	27,50	> 3,0	MRN 12	3560	11,8	6,0	5,00	0,4462	
	17,87	78,4	28,70	> 3,0	MRN 22	3590	15,2	9,4	5,00	1,5647	
	18,84	74,3	30,56	> 3,0	MRN 32	4860	19,6	13,8	5,00	2,0717	
	17,59	79,6	28,70	> 3,0	MRN 42	7410	41,1	35,3	5,00	6,8426	

## Getriebe - Gearboxes - Riduttori RN

1400 rpm

Selezione Motoriduttore - Geared Motor Selection - Getriebemotorauswahl

P <sub>1</sub> [kW]	i <sub>n</sub>	i <sub>r</sub>	N <sub>2</sub> [rpm]	M <sub>2</sub> [Nm]	FS	Tipo - Size - Größe	F <sub>r2</sub> [N]	MRN [kg]	FRN [kg]	J <sub>m</sub> × 10 <sup>-4</sup>	J <sub>1</sub> × 10 <sup>-4</sup>
0,25	20,0	20,29	69	32,69	> 3,0	MRN 12	3710	11,8	6,0	5,00	0,4149
		19,66	71,2	31,94	> 3,0	MRN 22	4810	15,2	9,4	5,00	1,6024
		20,03	69,9	32,50	> 3,0	MRN 32	7400	19,6	13,8	5,00	2,2256
22,4	22,4	25,37	55,2	42,50	> 3,0	MRN 12	3850	11,8	6,0	5,00	0,3892
		22,67	61,8	36,90	> 3,0	MRN 22	3800	15,2	9,4	5,00	1,4958
		22,18	63,1	36,18	> 3,0	MRN 32	5000	19,6	13,8	5,00	1,9456
25,0	25,0	22,69	61,7	37,30	> 3,0	MRN 42	8160	41,1	35,3	5,00	6,4129
		24,21	57,8	40,00	> 3,0	MRN 22	4970	15,2	9,4	5,00	1,5348
		26,62	52,6	43,48	> 3,0	MRN 32	7750	19,6	13,8	5,00	1,9888
28,0	28,0	29,32	47,8	47,32	> 3,0	MRN 22	4770	15,2	9,4	5,00	1,4440
		28,93	48,4	46,55	> 3,0	MRN 32	5550	19,6	13,8	5,00	1,7952
		28,28	49,5	46,35	> 3,0	MRN 42	8920	41,1	35,3	5,00	6,1008
31,5	31,5	30,59	45,8	50,00	2,8	MRN 12	4070	11,8	6,0	5,00	0,3789
		30,71	45,6	50,00	> 3,0	MRN 22	5180	15,2	9,4	5,00	1,4772
		31,33	44,7	52,63	> 3,0	MRN 32	7920	19,6	13,8	5,00	1,8858
33,0	33,0	30	46,7	49,32	> 3,0	MRN 42	9290	41,1	35,3	5,00	6,2602
		33	42,4	54,05	3,0	MRN 12	4290	11,8	6,0	5,00	0,3685
		35,5	36,47	38,4	59,32	2,4	MRN 12	4700	11,8	6,0	5,00
35,5	35,5	34,52	40,6	55,56	> 3,0	MRN 22	5420	15,2	9,4	5,00	1,4202
		34,5	40,6	56,25	> 3,0	MRN 32	7320	19,6	13,8	5,00	1,7221
		37,39	37,4	61,67	> 3,0	MRN 42	10030	41,1	35,3	5,00	6,0256
40,0	40,0	39,78	35,2	64,81	2,2	MRN 12	4870	11,8	6,0	5,00	0,3635
		39,52	35,4	63,60	2,3	MRN 13	4762	11,6	5,8	5,00	0,2554
		39,72	35,2	63,83	> 3,0	MRN 22	5380	15,2	9,4	5,00	1,4329
40,0	40,0	36,34	38,5	58,41	> 3,0	MRN 23	5130	15,5	9,7	5,00	0,9994
		40,87	34,3	65,63	> 3,0	MRN 32	8250	19,6	13,8	5,00	1,7600
		35,86	39	58,33	> 3,0	MRN 33	6840	19,8	14,0	5,00	1,2294
45,0	45,0	38,12	36,7	62,50	> 3,0	MRN 42	10140	41,1	35,3	5,00	5,8382
		34,07	41,1	55,30	> 3,0	MRN 43	9670	43,3	37,5	5,00	4,3102
		43,96	31,8	71,43	2,0	MRN 12	4900	11,8	6,0	5,00	0,3585
45,0	45,0	46,78	29,9	74,70	> 3,0	MRN 22	5550	15,2	9,4	5,00	1,4122
		44,73	31,3	71,81	> 3,0	MRN 23	5070	15,5	9,7	5,00	0,9900
		47,5	29,5	80,00	> 3,0	MRN 32	9440	19,6	13,8	5,00	1,6310
50,0	50,0	44,2	31,7	72,37	> 3,0	MRN 33	5900	19,8	14,0	5,00	1,2052
		45,27	30,9	75,00	> 3,0	MRN 42	10720	41,1	35,3	5,00	5,8675
		42,59	32,9	68,94	> 3,0	MRN 43	10030	43,3	37,5	5,00	4,2058
50,0	50,0	48,98	28,6	79,55	1,8	MRN 12	4900	11,8	6,0	5,00	0,3539
		48,04	29,1	77,50	2,0	MRN 13	4600	11,6	5,8	5,00	0,2512
		51,19	27,3	81,67	3,0	MRN 22	5650	15,2	9,4	5,00	1,4027
56,0	56,0	48,74	28,7	80,77	> 3,0	MRN 32	8530	19,6	13,8	5,00	1,6974
		50,4	27,8	81,52	> 3,0	MRN 42	11110	41,1	35,3	5,00	5,7968
		52,07	26,9	85,94	1,3	MRN 12	5150	11,8	6,0	5,00	0,3499
60,0	60,0	55,91	25	90,12	> 3,0	MRN 23	4970	15,5	9,7	5,00	0,9828
		53,75	26	87,50	> 3,0	MRN 32	8640	19,6	13,8	5,00	1,6689
		55,31	25,3	90,63	> 3,0	MRN 33	5500	19,8	14,0	5,00	1,1864
60,0	60,0	56,67	24,7	92,11	> 3,0	MRN 42	11600	41,1	35,3	5,00	5,7318
		54,21	25,8	87,50	> 3,0	MRN 43	9830	43,3	37,5	5,00	4,1359
		62,78	22,3	103,45	1,2	MRN 12	5400	11,8	6,0	5,00	0,3459
60,0	60,0	62,54	22,4	101,19	1,7	MRN 13	4300	11,6	5,8	5,00	0,2474
		62,66	22,3	100,81	2,5	MRN 22	6040	15,2	9,4	5,00	1,3859

## RN Riduttori - Gearboxes - Getriebe

Selezione Motoriduttore - Geared Motor Selection - Getriebemotorauswahl

1400 rpm

P <sub>1</sub> [kW]	i <sub>n</sub>	i <sub>r</sub>	N <sub>2</sub> [rpm]	M <sub>2</sub> [Nm]	FS	Tipo - Size - Größe	F <sub>r2</sub> [N]	MRN [kg]	FRN [kg]	J <sub>m</sub> × 10 <sup>-4</sup>	J <sub>1</sub> × 10 <sup>-4</sup>	
0,25	63,0	67,1	20,9	109,38	> 3,0	MRN 32	9030	19,6	13,8	5,00	1,6180	
		66,13	21,2	107,61	> 3,0	MRN 43	10110	43,3	37,5	5,00	4,0833	
		71,0	71,57	19,6	113,97	2,7	MRN 23	5100	15,5	9,7	5,00	0,9772
	71,0	70,88	19,8	111,54	> 3,0	MRN 33	5500	19,8	14,0	5,00	1,1714	
		70,82	19,8	113,89	> 3,0	MRN 43	12640	43,3	37,5	5,00	4,0520	
		79,1	17,7	128,57	1,4	MRN 13	4000	11,6	5,8	5,00	0,2451	
	80,0	79,01	17,7	125,00	1,1	MRN 23	7160	15,5	9,7	5,00	0,9250	
		80,62	17,4	129,90	2,0	MRN 33	10880	19,8	14,0	5,00	1,0679	
		82,52	17	131,58	> 3,0	MRN 43	10510	43,3	37,5	5,00	3,7956	
	90,0	88,14	15,9	140,91	2,2	MRN 23	5200	15,5	9,7	5,00	0,9738	
		94,22	14,9	151,04	> 3,0	MRN 33	5500	19,8	14,0	5,00	1,1594	
		89,6	15,6	143,26	> 3,0	MRN 43	13650	43,3	37,5	5,00	4,0262	
	100,0	96,36	14,5	155,17	1,2	MRN 13	4000	11,6	5,8	5,00	0,2437	
		101,07	13,9	160,71	1,1	MRN 23	7190	15,5	9,7	5,00	0,9223	
		103,34	13,5	166,67	2,0	MRN 33	10730	19,8	14,0	5,00	1,0614	
		106,48	13,1	168,33	> 3,0	MRN 43	10930	43,3	37,5	5,00	3,7770	
	112,0	111,82	12,5	180,23	1,7	MRN 23	5200	15,5	9,7	5,00	0,9710	
		110,89	12,6	176,83	> 3,0	MRN 33	5500	19,8	14,0	5,00	1,1543	
	125,0	124,39	11,3	196,43	1,1	MRN 23	6700	15,5	9,7	5,00	0,9206	
		127,37	11	205,88	2,0	MRN 33	9700	19,8	14,0	5,00	1,0575	
	140,0	144,62	9,68	228,45	1,2	MRN 23	6100	15,5	9,7	5,00	0,9688	
		144,64	9,68	230,16	2,5	MRN 33	5500	19,8	14,0	5,00	1,1483	
		132,69	10,6	215,91	> 3,0	MRN 43	12260	43,3	37,5	5,00	4,0051	
	160,0	155,49	9	250,00	1,0	MRN 23	6200	15,5	9,7	5,00	0,9193	
		159,41	8,78	255,95	1,7	MRN 33	9400	19,8	14,0	5,00	1,0542	
		160,69	8,71	256,76	3,0	MRN 43	14590	43,3	37,5	5,00	3,9942	
	180,0	172,5	8,12	279,07	1,7	MRN 33	8600	19,8	14,0	5,00	1,1454	
		173,9	8,05	277,78	2,9	MRN 43	14570	43,3	37,5	5,00	3,9843	
	200,0	199,03	7,03	325,00	0,8	MRN 23	6200	15,5	9,7	5,00	0,9183	
		204,26	6,85	325,76	1,3	MRN 33	9400	19,8	14,0	5,00	1,0515	
200,0	201,13	6,96	319,77	1,7	MRN 43	16680	43,3	37,5	5,00	3,7478		
224,0	237,5	5,89	380,95	0,8	MRN 33	11100	19,8	14,0	5,00	1,1417		
224,0	217	6,45	350,88	2,3	MRN 43	15210	43,3	37,5	5,00	3,9773		
280,0	271,53	5,16	430,00	1,0	MRN 33	9400	19,8	14,0	5,00	1,0493		
280,0	280	5	444,44	1,8	MRN 43	16030	43,3	37,5	5,00	3,7425		
315,0	319,58	4,38	511,90	0,8	MRN 33	9400	19,8	14,0	5,00	1,0483		
355,0	348,92	4,01	555,56	1,4	MRN 43	16500	43,3	37,5	5,00	3,7381		
450,0	422,55	3,31	666,67	1,2	MRN 43	16500	43,3	37,5	5,00	3,7354		
500,0	470,4	2,98	740,74	1,1	MRN 43	16500	43,3	37,5	5,00	3,7336		
560,0	528,89	2,65	833,33	1,0	MRN 43	17000	43,3	37,5	5,00	3,7328		
0,37	6,3	5,76	243	13,78	> 3,0	MRN 22	3200	15,6	9,4	8,00	2,5855	
		5,59	250	13,58	> 3,0	MRN 32	4760	20,0	13,8	8,00	4,8684	
		5,74	244	13,90	> 3,0	MRN 42	5030	41,5	35,3	8,00	13,0943	
	7,1	6,59	212	15,95	> 3,0	MRN 12	3350	12,2	6,0	8,00	0,8414	
		7,37	190	17,29	> 3,0	MRN 22	3450	15,6	9,4	8,00	2,1881	
		7,17	195	17,29	> 3,0	MRN 32	5180	20,0	13,8	8,00	3,8232	
	8,0	7,26	193	17,61	> 3,0	MRN 42	5190	41,5	35,3	8,00	10,7969	
		7,95	176	19,24	> 3,0	MRN 12	3470	12,2	6,0	8,00	0,7600	
		7,8	179	18,50	> 3,0	MRN 22	3530	15,6	9,4	8,00	2,2972	
			7,9	177	19,28	> 3,0	MRN 32	5410	20,0	13,8	8,00	3,9288

## Getriebe - Gearboxes - Riduttori RN

1400 rpm

Selezione Motoriduttore - Geared Motor Selection - Getriebemotorauswahl

P <sub>1</sub> [kW]	i <sub>n</sub>	i <sub>r</sub>	N <sub>2</sub> [rpm]	M <sub>2</sub> [Nm]	FS	Tipo - Size - Größe	F <sub>r2</sub> [N]	MRN [kg]	FRN [kg]	J <sub>m</sub> × 10 <sup>-4</sup>	J <sub>1</sub> × 10 <sup>-4</sup>
0,37	8,0	7,59	185	18,37	> 3,0	MRN 42	5680	41,5	35,3	8,00	11,2674
	9,0	8,32	168	19,92	> 3,0	MRN 12	3580	12,2	6,0	8,00	0,6786
	9,07	154	21,66	> 3,0	MRN 22	3690	15,6	9,4	8,00	1,9599	
	8,84	158	21,40	> 3,0	MRN 32	5180	20,0	13,8	8,00	3,2176	
	9,08	154	21,95	> 3,0	MRN 42	5660	41,5	35,3	8,00	9,2579	
10,0	10,11	138	24,13	> 3,0	MRN 12	3490	12,2	6,0	8,00	0,5849	
	9,98	140	23,64	> 3,0	MRN 22	3850	15,6	9,4	8,00	2,0120	
	10,13	138	24,67	> 3,0	MRN 32	5890	20,0	13,8	8,00	3,2515	
	9,6	146	23,21	> 3,0	MRN 42	6200	41,5	35,3	8,00	9,6555	
	11,2	11,33	124	26,72	> 3,0	MRN 22	3890	15,6	9,4	8,00	1,7848
	11,06	127	26,86	> 3,0	MRN 32	4550	20,0	13,8	8,00	2,7466	
12,5	11,55	121	28,06	> 3,0	MRN 42	6170	41,5	35,3	8,00	8,0995	
	12,19	115	30,06	> 3,0	MRN 12	3470	12,2	6,0	8,00	0,5416	
	12,29	114	29,34	> 3,0	MRN 22	4140	15,6	9,4	8,00	1,8436	
	12,49	112	30,57	> 3,0	MRN 32	6330	20,0	13,8	8,00	2,8412	
	12	117	29,10	> 3,0	MRN 42	6720	41,5	35,3	8,00	8,5274	
	14,0	13,17	106	32,13	> 3,0	MRN 12	3450	12,2	6,0	8,00	0,4982
	14,51	96,5	34,69	> 3,0	MRN 22	3720	15,6	9,4	8,00	1,6479	
	14,18	98,8	34,45	> 3,0	MRN 32	4700	20,0	13,8	8,00	2,3720	
	14,09	99,3	34,04	> 3,0	MRN 42	6810	41,5	35,3	8,00	7,4107	
16,0	15,87	88,2	39,85	> 3,0	MRN 12	3450	12,2	6,0	8,00	0,4722	
	15,36	91,2	37,00	> 3,0	MRN 22	4480	15,6	9,4	8,00	1,7103	
	15,63	89,6	37,97	> 3,0	MRN 32	6830	20,0	13,8	8,00	2,5063	
	15,27	91,7	37,00	> 3,0	MRN 42	7330	41,5	35,3	8,00	7,6485	
	18,0	16,65	84,1	40,70	> 3,0	MRN 12	3560	12,2	6,0	8,00	0,4462
	17,87	78,4	42,48	> 3,0	MRN 22	3590	15,6	9,4	8,00	1,5647	
	18,84	74,3	45,22	> 3,0	MRN 32	4860	20,0	13,8	8,00	2,0717	
	17,59	79,6	42,48	> 3,0	MRN 42	7410	41,5	35,3	8,00	6,8426	
	20,0	20,29	69	48,38	> 3,0	MRN 12	3710	12,2	6,0	8,00	0,4149
	19,66	71,2	47,28	> 3,0	MRN 22	4810	15,6	9,4	8,00	1,6024	
	20,03	69,9	48,10	> 3,0	MRN 32	7400	20,0	13,8	8,00	2,2256	
	22,4	25,37	55,2	62,90	> 3,0	MRN 12	3850	12,2	6,0	8,00	0,3892
	22,67	61,8	54,62	> 3,0	MRN 22	3800	15,6	9,4	8,00	1,4958	
	22,18	63,1	53,55	> 3,0	MRN 32	5000	20,0	13,8	8,00	1,9456	
	22,69	61,7	55,21	> 3,0	MRN 42	8160	41,5	35,3	8,00	6,4129	
25,0	24,21	57,8	59,20	> 3,0	MRN 22	4970	15,6	9,4	8,00	1,5348	
	26,62	52,6	64,35	> 3,0	MRN 32	7750	20,0	13,8	8,00	1,9888	
28,0	29,32	47,8	70,04	> 3,0	MRN 22	4770	15,6	9,4	8,00	1,4440	
28,0	28,93	48,4	68,90	> 3,0	MRN 32	5550	20,0	13,8	8,00	1,7952	
	28,28	49,5	68,60	> 3,0	MRN 42	8920	41,5	35,3	8,00	6,1008	
31,5	30,59	45,8	74,00	1,9	MRN 12	4070	12,2	6,0	8,00	0,3789	
	30,71	45,6	74,00	> 3,0	MRN 22	5180	15,6	9,4	8,00	1,4772	
	31,33	44,7	77,89	> 3,0	MRN 32	7920	20,0	13,8	8,00	1,8858	
	30	46,7	73,00	> 3,0	MRN 42	9290	41,5	35,3	8,00	6,2602	
	33,0	33	42,4	80,00	2,0	MRN 12	4290	12,2	6,0	8,00	0,3685
	35,5	36,47	38,4	87,80	1,6	MRN 12	4700	12,2	6,0	8,00	0,3626
	34,52	40,6	82,22	2,7	MRN 22	5420	15,6	9,4	8,00	1,4202	
	34,5	40,6	83,25	> 3,0	MRN 32	7320	20,0	13,8	8,00	1,7221	
	37,39	37,4	91,27	> 3,0	MRN 42	10030	41,5	35,3	8,00	6,0256	
40,0	39,78	35,2	95,93	1,5	MRN 12	4870	12,2	6,0	8,00	0,3635	



## RN Riduttori - Gearboxes - Getriebe

Selezione Motoriduttore - Geared Motor Selection - Getriebemotorauswahl

1400 rpm

P <sub>1</sub> [kW]	i <sub>n</sub>	i <sub>r</sub>	N <sub>2</sub> [rpm]	M <sub>2</sub> [Nm]	FS	Tipo - Size - Größe	F <sub>r2</sub> [N]	MRN [kg]	FRN [kg]	J <sub>m</sub> × 10 <sup>-4</sup>	J <sub>1</sub> × 10 <sup>-4</sup>	
0,37	40,0	39,52	35,4	94,12	1,5	MRN 13	4762	12,0	5,8	8,00	0,2554	
		39,72	35,2	94,47	2,5	MRN 22	5380	15,6	9,4	8,00	1,4329	
		36,34	38,5	86,45	2,9	MRN 23	5130	15,9	9,7	8,00	0,9994	
		40,87	34,3	97,13	> 3,0	MRN 32	8250	20,0	13,8	8,00	1,7600	
		35,86	39	86,33	> 3,0	MRN 33	6840	20,2	14,0	8,00	1,2294	
		38,12	36,7	92,50	> 3,0	MRN 42	10140	41,5	35,3	8,00	5,8382	
		34,07	41,1	81,85	> 3,0	MRN 43	9670	43,7	37,5	8,00	4,3102	
		45,0	43,96	31,8	105,71	1,3	MRN 12	4900	12,2	6,0	8,00	0,3585
	45,0	46,78	29,9	110,55	2,2	MRN 22	5550	15,6	9,4	8,00	1,4122	
		44,73	31,3	106,28	2,5	MRN 23	5070	15,9	9,7	8,00	0,9900	
		47,5	29,5	118,40	2,7	MRN 32	9440	20,0	13,8	8,00	1,6310	
		44,2	31,7	107,11	> 3,0	MRN 33	5900	20,2	14,0	8,00	1,2052	
		45,27	30,9	111,00	> 3,0	MRN 42	10720	41,5	35,3	8,00	5,8675	
		42,59	32,9	102,03	> 3,0	MRN 43	10030	43,7	37,5	8,00	4,2058	
		50,0	48,98	28,6	117,73	1,2	MRN 12	4900	12,2	6,0	8,00	0,3539
		48,04	29,1	114,70	1,4	MRN 13	4600	12,0	5,8	8,00	0,2512	
50,0	51,19	27,3	120,87	2,0	MRN 22	5650	15,6	9,4	8,00	1,4027		
	48,74	28,7	119,54	> 3,0	MRN 32	8530	20,0	13,8	8,00	1,6974		
	50,4	27,8	120,65	> 3,0	MRN 42	11110	41,5	35,3	8,00	5,7968		
	56,0	52,07	26,9	127,19	0,9	MRN 12	5150	12,2	6,0	8,00	0,3499	
	55,91	25	133,37	2,3	MRN 23	4970	15,9	9,7	8,00	0,9828		
	53,75	26	129,50	> 3,0	MRN 32	8640	20,0	13,8	8,00	1,6689		
	55,31	25,3	134,13	> 3,0	MRN 33	5500	20,2	14,0	8,00	1,1864		
	56,67	24,7	136,32	> 3,0	MRN 42	11600	41,5	35,3	8,00	5,7318		
56,0	54,21	25,8	129,50	> 3,0	MRN 43	9830	43,7	37,5	8,00	4,1359		
	60,0	62,78	22,3	153,10	0,8	MRN 12	5400	12,2	6,0	8,00	0,3459	
	63,0	62,54	22,4	149,76	1,1	MRN 13	4300	12,0	5,8	8,00	0,2474	
	62,66	22,3	149,19	1,7	MRN 22	6040	15,6	9,4	8,00	1,3859		
	67,1	20,9	161,88	2,6	MRN 32	9030	20,0	13,8	8,00	1,6180		
	66,13	21,2	159,26	> 3,0	MRN 43	10110	43,7	37,5	8,00	4,0833		
	71,0	71,57	19,6	168,68	1,8	MRN 23	5100	15,9	9,7	8,00	0,9772	
	70,88	19,8	165,08	> 3,0	MRN 33	5500	20,2	14,0	8,00	1,1714		
71,0	70,82	19,8	168,56	2,4	MRN 43	12640	43,7	37,5	8,00	4,0520		
	80,0	79,1	17,7	190,29	0,9	MRN 13	4000	12,0	5,8	8,00	0,2451	
	79,01	17,7	185,00	0,8	MRN 23	7160	15,9	9,7	8,00	0,9250		
	80,62	17,4	192,25	1,4	MRN 33	10880	20,2	14,0	8,00	1,0679		
	82,52	17	194,74	> 3,0	MRN 43	10510	43,7	37,5	8,00	3,7956		
	90,0	88,14	15,9	208,55	1,5	MRN 23	5200	15,9	9,7	8,00	0,9738	
	94,22	14,9	223,54	2,6	MRN 33	5500	20,2	14,0	8,00	1,1594		
	89,6	15,6	212,02	2,4	MRN 43	13650	43,7	37,5	8,00	4,0262		
100,0	96,36	14,5	229,66	0,8	MRN 13	4000	12,0	5,8	8,00	0,2437		
	101,07	13,9	237,86	0,8	MRN 23	7190	15,9	9,7	8,00	0,9223		
	103,34	13,5	246,67	1,4	MRN 33	10730	20,2	14,0	8,00	1,0614		
	106,48	13,1	249,13	> 3,0	MRN 43	10930	43,7	37,5	8,00	3,7770		
	112,0	111,82	12,5	266,74	1,2	MRN 23	5200	15,9	9,7	8,00	0,9710	
	110,89	12,6	261,71	2,2	MRN 33	5500	20,2	14,0	8,00	1,1543		
	125,0	124,39	11,3	290,71	0,8	MRN 23	6700	15,9	9,7	8,00	0,9206	
	127,37	11	304,71	1,4	MRN 33	9700	20,2	14,0	8,00	1,0575		
140,0	144,62	9,68	338,10	0,8	MRN 23	6100	15,9	9,7	8,00	0,9688		
	144,64	9,68	340,63	1,7	MRN 33	5500	20,2	14,0	8,00	1,1483		

## Getriebe - Gearboxes - Riduttori RN

1400 rpm

Selezione Motoriduttore - Geared Motor Selection - Getriebemotorauswahl

P <sub>1</sub> [kW]	i <sub>n</sub>	i <sub>r</sub>	N <sub>2</sub> [rpm]	M <sub>2</sub> [Nm]	FS	Tipo - Size - Größe	F <sub>r2</sub> [N]	MRN [kg]	FRN [kg]	J <sub>m</sub> × 10 <sup>-4</sup>	J <sub>1</sub> × 10 <sup>-4</sup>
0,37	140,0	132,69	10,6	319,55	3,0	MRN 43	12260	43,7	37,5	8,00	4,0051
		155,49	9	370,00	0,7	MRN 23	6200	15,9	9,7	8,00	0,9193
		159,41	8,78	378,81	1,1	MRN 33	9400	20,2	14,0	8,00	1,0542
		160,69	8,71	380,00	2,0	MRN 43	14590	43,7	37,5	8,00	3,9942
	180,0	172,5	8,12	413,02	1,2	MRN 33	8600	20,2	14,0	8,00	1,1454
		173,9	8,05	411,11	1,9	MRN 43	14570	43,7	37,5	8,00	3,9843
	200,0	204,26	6,85	482,12	0,9	MRN 33	9400	20,2	14,0	8,00	1,0515
		201,13	6,96	473,26	1,2	MRN 43	16680	43,7	37,5	8,00	3,7478
	224,0	217	6,45	519,30	1,5	MRN 43	15210	43,7	37,5	8,00	3,9773
	280,0	280	5	657,78	1,2	MRN 43	16030	43,7	37,5	8,00	3,7425
	355,0	348,92	4,01	822,22	1,0	MRN 43	16500	43,7	37,5	8,00	3,7381
	450,0	422,55	3,31	986,67	0,8	MRN 43	16500	43,7	37,5	8,00	3,7354
	500,0	470,4	2,98	1096,30	0,7	MRN 43	16500	43,7	37,5	8,00	3,7336
	0,55	6,3	5,76	243	20,49	< 3,0	MRN 22	3200	17,9	9,4	14,00
5,59			250	20,18	< 3,0	MRN 32	4760	22,3	13,8	14,00	4,8684
5,74			244	20,66	< 3,0	MRN 42	5030	43,8	35,3	14,00	13,0943
5,64			248	20,30	< 3,0	MRN 52	7550	73,7	65,2	14,00	37,6347
7,1		5,77	250	20,13	< 3,0	MRN 62	10060	123,3	114,8	14,00	84,0612
		6,59	212	23,71	< 3,0	MRN 12	3350	14,5	6,0	14,00	0,8414
		7,37	190	25,71	< 3,0	MRN 22	3450	17,9	9,4	14,00	2,1881
		7,17	195	25,71	< 3,0	MRN 32	5180	22,3	13,8	14,00	3,8232
8,0		7,26	193	26,17	< 3,0	MRN 42	5190	43,8	35,3	14,00	10,7969
		7,46	188	26,86	< 3,0	MRN 52	8250	73,7	65,2	14,00	31,2885
		7,39	189	26,63	< 3,0	MRN 62	9540	123,3	114,8	14,00	68,0211
		7,95	176	28,60	< 3,0	MRN 12	3470	14,5	6,0	14,00	0,7600
		7,8	179	27,50	< 3,0	MRN 22	3530	17,9	9,4	14,00	2,2972
		7,9	177	28,66	< 3,0	MRN 32	5410	22,3	13,8	14,00	3,9288
9,0		7,59	185	27,30	< 3,0	MRN 42	5680	43,8	35,3	14,00	11,2674
		7,66	183	27,62	< 3,0	MRN 52	8410	73,7	65,2	14,00	31,9539
		7,97	176	28,74	< 3,0	MRN 62	11380	123,3	114,8	14,00	68,6806
		8,32	168	29,62	< 3,0	MRN 12	3580	14,5	6,0	14,00	0,6786
		9,07	154	32,20	< 3,0	MRN 22	3690	17,9	9,4	14,00	1,9599
		8,84	158	31,81	< 3,0	MRN 32	5180	22,3	13,8	14,00	3,2176
10,0		9,08	154	32,63	< 3,0	MRN 42	5660	43,8	35,3	14,00	9,2579
		9,46	148	34,07	< 3,0	MRN 52	8900	73,7	65,2	14,00	27,6749
		9,38	149	33,79	< 3,0	MRN 62	9030	123,3	114,8	14,00	56,8499
		10,11	138	35,87	< 3,0	MRN 12	3490	14,5	6,0	14,00	0,5849
		9,98	140	35,14	< 3,0	MRN 22	3850	17,9	9,4	14,00	2,0120
		10,13	138	36,67	< 3,0	MRN 32	5890	22,3	13,8	14,00	3,2515
11,2		9,6	146	34,50	< 3,0	MRN 42	6200	43,8	35,3	14,00	9,6555
		10,13	138	36,56	< 3,0	MRN 52	9280	73,7	65,2	14,00	28,0395
		10,54	133	37,93	< 3,0	MRN 62	12550	123,3	114,8	14,00	58,6662
		11,33	124	39,72	< 3,0	MRN 22	3890	17,9	9,4	14,00	1,7848
		11,06	127	39,93	< 3,0	MRN 32	4550	22,3	13,8	14,00	2,7466
		11,55	121	41,71	< 3,0	MRN 42	6170	43,8	35,3	14,00	8,0995
12,5		11,45	122	41,18	< 3,0	MRN 52	8400	73,7	65,2	14,00	25,5151
		11,36	123	40,89	< 3,0	MRN 62	5620	123,3	114,8	14,00	50,1639
	12,19	115	44,69	2,9	MRN 12	3470	14,5	6,0	14,00	0,5416	
	12,29	114	43,62	< 3,0	MRN 22	4140	17,9	9,4	14,00	1,8436	
	12,49	112	45,43	< 3,0	MRN 32	6330	22,3	13,8	14,00	2,8412	

## RN Riduttori - Gearboxes - Getriebe

Selezione Motoriduttore - Geared Motor Selection - Getriebemotorauswahl

1400 rpm

P <sub>1</sub> [kW]	i <sub>n</sub>	i <sub>r</sub>	N <sub>2</sub> [rpm]	M <sub>2</sub> [Nm]	FS	Tipo - Size - Größe	F <sub>r2</sub> [N]	MRN [kg]	FRN [kg]	J <sub>m</sub> × 10 <sup>-4</sup>	J <sub>1</sub> × 10 <sup>-4</sup>	
0,55	12,5	12	117	43,26	< 3,0	MRN 42	6720	43,8	35,3	14,00	8,5274	
		12,85	109	46,29	< 3,0	MRN 52	10080	73,7	65,2	14,00	25,6545	
14,0	14,0	13,17	106	47,76	< 3,0	MRN 12	3450	14,5	6,0	14,00	0,4982	
		14,51	96,5	51,56	< 3,0	MRN 22	3720	17,9	9,4	14,00	1,6479	
		14,18	98,8	51,21	< 3,0	MRN 32	4700	22,3	13,8	14,00	2,3720	
		14,09	99,3	50,60	< 3,0	MRN 42	6810	43,8	35,3	14,00	7,4107	
		14,12	99,2	50,89	< 3,0	MRN 52	8470	73,7	65,2	14,00	23,7029	
		14	100	50,38	< 3,0	MRN 62	5450	123,3	114,8	14,00	44,5468	
		15,87	88,2	59,23	2,4	MRN 12	3450	14,5	6,0	14,00	0,4722	
		15,36	91,2	55,00	< 3,0	MRN 22	4480	17,9	9,4	14,00	1,7103	
		15,63	89,6	56,45	< 3,0	MRN 32	6830	22,3	13,8	14,00	2,5063	
		15,27	91,7	55,00	< 3,0	MRN 42	7330	43,8	35,3	14,00	7,6485	
16,0	16,0	15,56	90	55,95	< 3,0	MRN 52	10780	73,7	65,2	14,00	24,1384	
		16,19	86,4	58,37	< 3,0	MRN 62	11630	123,3	114,8	14,00	46,1997	
		16,65	84,1	60,50	2,7	MRN 12	3560	14,5	6,0	14,00	0,4462	
		17,87	78,4	63,15	< 3,0	MRN 22	3590	17,9	9,4	14,00	1,5647	
		18,84	74,3	67,22	< 3,0	MRN 32	4860	22,3	13,8	14,00	2,0717	
		17,59	79,6	63,15	< 3,0	MRN 42	7410	43,8	35,3	14,00	6,8426	
		17,85	78,4	64,50	< 3,0	MRN 52	8680	73,7	65,2	14,00	22,1741	
		17,7	79,1	63,77	< 3,0	MRN 62	3100	123,3	114,8	14,00	39,8027	
		20,29	69	71,92	2,4	MRN 12	3710	14,5	6,0	14,00	0,4149	
		19,66	71,2	70,28	< 3,0	MRN 22	4810	17,9	9,4	14,00	1,6024	
20,0	20,0	20,03	69,9	71,50	< 3,0	MRN 32	7400	22,3	13,8	14,00	2,2256	
		19,19	73	68,89	< 3,0	MRN 52	11580	73,7	65,2	14,00	22,7969	
		19,96	70,1	71,75	< 3,0	MRN 62	15790	123,3	114,8	14,00	41,9382	
		22,4	25,37	55,2	93,50	1,8	MRN 12	3850	14,5	6,0	14,00	0,3892
		22,67	61,8	81,19	< 3,0	MRN 22	3800	17,9	9,4	14,00	1,4958	
		22,18	63,1	79,61	< 3,0	MRN 32	5000	22,3	13,8	14,00	1,9456	
		22,69	61,7	82,06	< 3,0	MRN 42	8160	43,8	35,3	14,00	6,4129	
		23,45	59,7	84,81	< 3,0	MRN 52	8020	73,7	65,2	14,00	20,8963	
		23,25	60,2	83,92	< 3,0	MRN 62	8000	123,3	114,8	14,00	35,8331	
		25,0	24,21	57,8	88,00	2,7	MRN 12	4970	17,9	9,4	14,00	1,5348
25,0	25,0	26,62	52,6	95,65	< 3,0	MRN 32	7750	22,3	13,8	14,00	1,9888	
		24,26	57,7	86,84	< 3,0	MRN 52	12560	73,7	65,2	14,00	21,6073	
		25,24	55,5	90,66	< 3,0	MRN 62	16780	123,3	114,8	14,00	38,1707	
		28,0	29,32	47,8	104,11	2,5	MRN 12	4770	17,9	9,4	14,00	1,4440
		28,93	48,4	102,41	< 3,0	MRN 32	5550	22,3	13,8	14,00	1,7952	
		28,28	49,5	101,98	< 3,0	MRN 42	8920	43,8	35,3	14,00	6,1008	
		27,55	50,8	98,76	< 3,0	MRN 52	8090	73,7	65,2	14,00	20,3546	
		27,69	50,6	99,92	< 3,0	MRN 62	6000	123,3	114,8	14,00	34,0539	
		31,5	30,59	45,8	110,00	1,3	MRN 12	4070	14,5	6,0	14,00	0,3789
		31,5	31,5	30,71	45,6	110,00	2,2	MRN 22	5180	17,9	9,4	14,00
31,33	44,7			115,79	< 3,0	MRN 32	7920	22,3	13,8	14,00	1,8858	
30	46,7			108,51	< 3,0	MRN 42	9290	43,8	35,3	14,00	6,2602	
30,02	46,6			107,96	< 3,0	MRN 52	9610	73,7	65,2	14,00	20,1029	
30,38	46,1			109,47	< 3,0	MRN 62	7160	123,3	114,8	14,00	33,2259	
33,0	33			42,4	118,92	1,3	MRN 12	4290	14,5	6,0	14,00	0,3685
35,5	36,47			38,4	130,51	1,1	MRN 12	4700	14,5	6,0	14,00	0,3626
34,52	40,6			122,22	1,8	MRN 22	5420	17,9	9,4	14,00	1,4202	
34,5	40,6			123,75	< 3,0	MRN 32	7320	22,3	13,8	14,00	1,7221	

## Getriebe - Gearboxes - Riduttori RN

1400 rpm

Selezione Motoriduttore - Geared Motor Selection - Getriebemotorauswahl

P <sub>1</sub> [kW]	i <sub>n</sub>	i <sub>r</sub>	N <sub>2</sub> [rpm]	M <sub>2</sub> [Nm]	FS	Tipo - Size - Größe	F <sub>r2</sub> [N]	MRN [kg]	FRN [kg]	J <sub>m</sub> × 10 <sup>-4</sup>	J <sub>1</sub> × 10 <sup>-4</sup>
0,55	35,5	37,39	37,4	135,67	< 3,0	MRN 42	10030	43,8	35,3	14,00	6,0256
		36,31	38,6	130,00	< 3,0	MRN 52	13530	73,7	65,2	14,00	19,6654
		37,35	37,5	134,30	< 3,0	MRN 62	16090	123,3	114,8	14,00	31,7360
	40,0	39,72	35,2	140,43	1,7	MRN 22	5380	17,9	9,4	14,00	1,4329
		36,34	38,5	128,50	1,9	MRN 23	5130	18,2	9,7	14,00	0,9994
		40,87	34,3	144,38	2,9	MRN 32	8250	22,3	13,8	14,00	1,7600
		35,86	39	128,33	< 3,0	MRN 33	6840	22,5	14,0	14,00	1,2294
		38,12	36,7	137,50	< 3,0	MRN 42	10140	43,8	35,3	14,00	5,8382
		34,07	41,1	121,67	< 3,0	MRN 43	9670	46,0	37,5	14,00	4,3102
		40,79	34,3	146,28	8,5	MRN 52	14620	73,7	65,2	14,00	19,9025
		37,28	37,6	131,52	< 3,0	MRN 53	9220	78,3	69,8	14,00	13,8553
		39,49	35,5	142,78	< 3,0	MRN 62	18170	123,3	114,8	14,00	33,3872
		38,2	36,7	134,40	< 3,0	MRN 63	7350	129,5	121,0	14,00	22,6869
	45,0	46,78	29,9	164,33	1,5	MRN 22	5550	17,9	9,4	14,00	1,4122
		44,73	31,3	157,98	1,7	MRN 23	5070	18,2	9,7	14,00	0,9900
		47,5	29,5	176,00	1,8	MRN 32	9440	22,3	13,8	14,00	1,6310
		44,2	31,7	159,21	< 3,0	MRN 33	5900	22,5	14,0	14,00	1,2052
		45,27	30,9	165,00	< 3,0	MRN 42	10720	43,8	35,3	14,00	5,8675
		42,59	32,9	151,67	< 3,0	MRN 43	10030	46,0	37,5	14,00	4,2058
		45,38	30,8	163,51	< 3,0	MRN 52	15630	73,7	65,2	14,00	19,2544
47,28		29,6	167,95	< 3,0	MRN 53	8610	78,3	69,8	14,00	13,7108	
43,31		32,3	156,39	< 3,0	MRN 62	18380	123,3	114,8	14,00	32,6717	
50,0		51,19	27,3	179,67	1,4	MRN 22	5650	17,9	9,4	14,00	1,4027
56,0	48,74	28,7	177,69	2,4	MRN 32	8530	22,3	13,8	14,00	1,6974	
	50,4	27,8	179,35	< 3,0	MRN 42	11110	43,8	35,3	14,00	5,7968	
	49,33	28,4	178,75	< 3,0	MRN 52	15030	73,7	65,2	14,00	19,5092	
	53,26	26,3	192,50	< 3,0	MRN 62	18970	123,3	114,8	14,00	31,3694	
	48,44	28,9	171,56	< 3,0	MRN 63	7670	129,5	121,0	14,00	22,2684	
	55,91	25	198,26	1,6	MRN 23	4970	18,2	9,7	14,00	0,9828	
	53,75	26	192,50	2,2	MRN 32	8640	22,3	13,8	14,00	1,6689	
	55,31	25,3	199,38	2,9	MRN 33	5500	22,5	14,0	14,00	1,1864	
	56,67	24,7	202,63	< 3,0	MRN 42	11600	43,8	35,3	14,00	5,7318	
	54,21	25,8	192,50	< 3,0	MRN 43	9830	46,0	37,5	14,00	4,1359	
63,0	57,27	24,4	200,52	< 3,0	MRN 53	8800	78,3	69,8	14,00	13,6244	
	59,89	23,4	216,39	< 3,0	MRN 62	19310	123,3	114,8	14,00	30,7868	
	58,68	23,9	207,78	< 3,0	MRN 63	7800	129,5	121,0	14,00	22,0179	
	62,66	22,3	221,77	1,1	MRN 22	6040	17,9	9,4	14,00	1,3859	
	67,1	20,9	240,63	1,7	MRN 32	9030	22,3	13,8	14,00	1,6180	
	66,13	21,2	236,74	< 3,0	MRN 43	10110	46,0	37,5	14,00	4,0833	
	61,67	22,7	223,44	< 3,0	MRN 52	15530	73,7	65,2	14,00	19,1667	
	71,0	71,57	19,6	250,74	1,2	MRN 23	5100	18,2	9,7	14,00	0,9772
	70,88	19,8	245,38	2,4	MRN 33	5500	22,5	14,0	14,00	1,1714	
	70,82	19,8	250,56	1,6	MRN 43	12640	46,0	37,5	14,00	4,0520	
80,0	70,6	19,8	246,79	< 3,0	MRN 53	9010	78,3	69,8	14,00	13,5519	
	72,33	19,4	256,16	< 3,0	MRN 63	7800	129,5	121,0	14,00	21,8075	
	80,62	17,4	285,78	0,9	MRN 33	10880	22,5	14,0	14,00	1,0679	
	82,52	17	289,47	< 3,0	MRN 43	10510	46,0	37,5	14,00	3,7956	
	79,72	17,6	279,71	< 3,0	MRN 63	25090	129,5	121,0	14,00	19,9592	
90,0	88,14	15,9	310,00	1,0	MRN 23	5200	18,2	9,7	14,00	0,9738	
	94,22	14,9	332,29	1,7	MRN 33	5500	22,5	14,0	14,00	1,1594	

## RN Riduttori - Gearboxes - Getriebe

Selezione Motoriduttore - Geared Motor Selection - Getriebemotorauswahl

1400 rpm

P <sub>1</sub> [kW]	i <sub>n</sub>	i <sub>r</sub>	N <sub>2</sub> [rpm]	M <sub>2</sub> [Nm]	FS	Tipo - Size - Größe	F <sub>r2</sub> [N]	MRN [kg]	FRN [kg]	J <sub>m</sub> × 10 <sup>-4</sup>	J <sub>1</sub> × 10 <sup>-4</sup>
0,55	90,0	89,6	15,6	315,17	1,6	MRN 43	13650	46,0	37,5	14,00	4,0262
		89,26	15,7	314,03	> 3,0	MRN 53	8500	78,3	69,8	14,00	13,4907
		91,45	15,3	322,41	> 3,0	MRN 63	7800	129,5	121,0	14,00	21,6298
	100,0	103,34	13,5	366,67	0,9	MRN 33	10730	22,5	14,0	14,00	1,0614
		106,48	13,1	370,33	2,7	MRN 43	10930	46,0	37,5	14,00	3,7770
		95,68	14,6	335,79	> 3,0	MRN 53	17820	78,3	69,8	14,00	12,7382
	112,0	105,42	13,3	369,29	> 3,0	MRN 63	22430	129,5	121,0	14,00	19,8591
		111,82	12,5	396,51	0,8	MRN 23	5200	18,2	9,7	14,00	0,9710
		110,89	12,6	389,02	1,5	MRN 33	5500	22,5	14,0	14,00	1,1543
	125,0	117,24	11,9	410,21	> 3,0	MRN 53	7200	78,3	69,8	14,00	13,4396
		127,37	11	452,94	0,9	MRN 33	9700	22,5	14,0	14,00	1,0575
		121,33	11,5	423,82	> 3,0	MRN 53	17330	78,3	69,8	14,00	12,7114
	140,0	120,13	11,7	425,00	> 3,0	MRN 63	7800	129,5	121,0	14,00	21,4811
		144,64	9,68	506,35	1,1	MRN 33	5500	22,5	14,0	14,00	1,1483
		132,69	10,6	475,00	2,0	MRN 43	12260	46,0	37,5	14,00	4,0051
	160,0	137,77	10,2	495,00	> 3,0	MRN 53	7200	78,3	69,8	14,00	13,4179
		143,08	9,78	505,41	> 3,0	MRN 63	7800	129,5	121,0	14,00	21,4145
		160,69	8,71	564,86	1,3	MRN 43	14590	46,0	37,5	14,00	3,9942
	180,0	150,12	9,33	519,44	> 3,0	MRN 53	12400	78,3	69,8	14,00	13,4079
		156,94	8,92	550,00	> 3,0	MRN 63	7900	129,5	121,0	14,00	21,3834
		173,9	8,05	611,11	1,3	MRN 43	14570	46,0	37,5	14,00	3,9843
	180,0	181,54	7,71	623,33	2,2	MRN 53	18220	78,3	69,8	14,00	13,3896
	200,0	192,98	7,25	675,00	> 3,0	MRN 63	21200	129,5	121,0	14,00	21,3276
	224,0	217	6,45	771,93	1,0	MRN 43	15210	46,0	37,5	14,00	3,9773
		229,08	6,11	807,07	1,7	MRN 53	19100	78,3	69,8	14,00	12,6660
		217	6,45	744,12	> 3,0	MRN 63	26700	129,5	121,0	14,00	21,3029
	250,0	252,39	5,55	893,75	2,9	MRN 63	22500	129,5	121,0	14,00	19,6541
	315,0	300,91	4,65	1060,71	1,3	MRN 53	19100	78,3	69,8	14,00	12,6544
		331,53	4,22	1191,67	2,2	MRN 63	22500	129,5	121,0	14,00	19,6213
	355,0	353,6	3,96	1237,50	1,1	MRN 53	19100	78,3	69,8	14,00	12,6493
400,0	385,28	3,63	1350,00	1,0	MRN 53	19100	78,3	69,8	14,00	12,6469	
	394,87	3,55	1430,00	1,8	MRN 63	22500	129,5	121,0	14,00	19,6063	
450,0	465,93	3	1650,00	0,8	MRN 53	19100	78,3	69,8	14,00	12,6425	
	433,13	3,23	1521,28	1,7	MRN 63	22500	129,5	121,0	14,00	19,5991	
500,0	532,58	2,63	1881,58	1,4	MRN 63	22500	129,5	121,0	14,00	19,5861	
560,0	598,89	2,34	2102,94	1,2	MRN 63	22500	129,5	121,0	14,00	19,5803	
0,75	6,3	5,76	243	27,94	> 3,0	MRN 22	3200	19,2	9,4	17,00	2,5855
		5,59	250	27,52	> 3,0	MRN 32	4760	23,6	13,8	17,00	4,8684
		5,74	244	28,18	> 3,0	MRN 42	5030	45,1	35,3	17,00	13,0943
		5,64	248	27,68	> 3,0	MRN 52	7550	75,0	65,2	17,00	37,6347
		5,77	250	27,45	> 3,0	MRN 62	10060	124,6	114,8	17,00	84,0612
	7,1	6,59	212	32,33	> 3,0	MRN 12	3350	15,8	6,0	17,00	0,8414
		7,37	190	35,05	> 3,0	MRN 22	3450	19,2	9,4	17,00	2,1881
		7,17	195	35,05	> 3,0	MRN 32	5180	23,6	13,8	17,00	3,8232
		7,26	193	35,69	> 3,0	MRN 42	5190	45,1	35,3	17,00	10,7969
		7,46	188	36,63	> 3,0	MRN 52	8250	75,0	65,2	17,00	31,2885
	8,0	7,39	189	36,31	> 3,0	MRN 62	9540	124,6	114,8	17,00	68,0211
		7,95	176	39,00	> 3,0	MRN 12	3470	15,8	6,0	17,00	0,7600
		7,8	179	37,50	> 3,0	MRN 22	3530	19,2	9,4	17,00	2,2972
		7,9	177	39,08	> 3,0	MRN 32	5410	23,6	13,8	17,00	3,9288



## Getriebe - Gearboxes - Riduttori RN

1400 rpm

Selezione Motoriduttore - Geared Motor Selection - Getriebemotorauswahl

P <sub>1</sub> [kW]	i <sub>n</sub>	i <sub>r</sub>	N <sub>2</sub> [rpm]	M <sub>2</sub> [Nm]	FS	Tipo - Size - Größe	F <sub>r2</sub> [N]	MRN [kg]	FRN [kg]	J <sub>m</sub> × 10 <sup>-4</sup>	J <sub>1</sub> × 10 <sup>-4</sup>
0,75	8,0	7,59	185	37,23	< 3,0	MRN 42	5680	45,1	35,3	17,00	11,2674
		7,66	183	37,67	< 3,0	MRN 52	8410	75,0	65,2	17,00	31,9539
9,0	9,0	7,97	176	39,19	< 3,0	MRN 62	11380	124,6	114,8	17,00	68,6806
		8,32	168	40,38	< 3,0	MRN 12	3580	15,8	6,0	17,00	0,6786
		9,07	154	43,90	< 3,0	MRN 22	3690	19,2	9,4	17,00	1,9599
		8,84	158	43,37	< 3,0	MRN 32	5180	23,6	13,8	17,00	3,2176
		9,08	154	44,50	< 3,0	MRN 42	5660	45,1	35,3	17,00	9,2579
		9,46	148	46,46	< 3,0	MRN 52	8900	75,0	65,2	17,00	27,6749
		9,38	149	46,08	< 3,0	MRN 62	9030	124,6	114,8	17,00	56,8499
10,0	10,0	10,11	138	48,91	< 3,0	MRN 12	3490	15,8	6,0	17,00	0,5849
		9,98	140	47,92	< 3,0	MRN 22	3850	19,2	9,4	17,00	2,0120
		10,13	138	50,00	< 3,0	MRN 32	5890	23,6	13,8	17,00	3,2515
		9,6	146	47,05	< 3,0	MRN 42	6200	45,1	35,3	17,00	9,6555
		10,13	138	49,86	< 3,0	MRN 52	9280	75,0	65,2	17,00	28,0395
		10,54	133	51,72	< 3,0	MRN 62	12550	124,6	114,8	17,00	58,6662
11,2	11,2	11,33	124	54,17	< 3,0	MRN 22	3890	19,2	9,4	17,00	1,7848
		11,06	127	54,45	< 3,0	MRN 32	4550	23,6	13,8	17,00	2,7466
		11,55	121	56,88	< 3,0	MRN 42	6170	45,1	35,3	17,00	8,0995
		11,45	122	56,16	< 3,0	MRN 52	8400	75,0	65,2	17,00	25,5151
		11,36	123	55,76	< 3,0	MRN 62	5620	124,6	114,8	17,00	50,1639
12,5	12,5	12,19	115	60,94	< 3,0	MRN 12	3470	15,8	6,0	17,00	0,5416
		12,29	114	59,48	< 3,0	MRN 22	4140	19,2	9,4	17,00	1,8436
		12,49	112	61,96	< 3,0	MRN 32	6330	23,6	13,8	17,00	2,8412
		12	117	58,99	< 3,0	MRN 42	6720	45,1	35,3	17,00	8,5274
		12,85	109	63,13	< 3,0	MRN 52	10080	75,0	65,2	17,00	25,6545
14,0	14,0	13,17	106	65,13	2,5	MRN 12	3450	15,8	6,0	17,00	0,4982
		14,51	96,5	70,31	< 3,0	MRN 22	3720	19,2	9,4	17,00	1,6479
		14,18	98,8	69,83	< 3,0	MRN 32	4700	23,6	13,8	17,00	2,3720
		14,09	99,3	69,00	< 3,0	MRN 42	6810	45,1	35,3	17,00	7,4107
		14,12	99,2	69,40	< 3,0	MRN 52	8470	75,0	65,2	17,00	23,7029
		14	100	68,70	< 3,0	MRN 62	5450	124,6	114,8	17,00	44,5468
16,0	16,0	15,87	88,2	80,77	1,7	MRN 12	3450	15,8	6,0	17,00	0,4722
		15,36	91,2	75,00	< 3,0	MRN 22	4480	19,2	9,4	17,00	1,7103
		15,63	89,6	76,97	< 3,0	MRN 32	6830	23,6	13,8	17,00	2,5063
		15,27	91,7	75,00	< 3,0	MRN 42	7330	45,1	35,3	17,00	7,6485
		15,56	90	76,29	< 3,0	MRN 52	10780	75,0	65,2	17,00	24,1384
		16,19	86,4	79,60	< 3,0	MRN 62	11630	124,6	114,8	17,00	46,1997
18,0	18,0	16,65	84,1	82,50	2,0	MRN 12	3560	15,8	6,0	17,00	0,4462
		17,87	78,4	86,11	< 3,0	MRN 22	3590	19,2	9,4	17,00	1,5647
		18,84	74,3	91,67	< 3,0	MRN 32	4860	23,6	13,8	17,00	2,0717
		17,59	79,6	86,11	< 3,0	MRN 42	7410	45,1	35,3	17,00	6,8426
		17,85	78,4	87,95	< 3,0	MRN 52	8680	75,0	65,2	17,00	22,1741
		17,7	79,1	86,96	< 3,0	MRN 62	3100	124,6	114,8	17,00	39,8027
20,0	20,0	20,29	69	98,08	1,7	MRN 12	3710	15,8	6,0	17,00	0,4149
		19,66	71,2	95,83	2,4	MRN 22	4810	19,2	9,4	17,00	1,6024
		20,03	69,9	97,50	< 3,0	MRN 32	7400	23,6	13,8	17,00	2,2256
		19,19	73	93,95	< 3,0	MRN 52	11580	75,0	65,2	17,00	22,7969
		19,96	70,1	97,84	< 3,0	MRN 62	15790	124,6	114,8	17,00	41,9382
22,4	22,4	25,37	55,2	127,50	1,3	MRN 12	3850	15,8	6,0	17,00	0,3892
		22,67	61,8	110,71	2,8	MRN 22	3800	19,2	9,4	17,00	1,4958

## RN Riduttori - Gearboxes - Getriebe

Selezione Motoriduttore - Geared Motor Selection - Getriebemotorauswahl

1400 rpm

P <sub>1</sub> [kW]	i <sub>n</sub>	i <sub>r</sub>	N <sub>2</sub> [rpm]	M <sub>2</sub> [Nm]	FS	Tipo - Size - Größe	F <sub>r2</sub> [N]	MRN [kg]	FRN [kg]	J <sub>m</sub> × 10 <sup>-4</sup>	J <sub>1</sub> × 10 <sup>-4</sup>
0,75	22,4	22,18	63,1	108,55	< 3,0	MRN 32	5000	23,6	13,8	17,00	1,9456
		22,69	61,7	111,90	< 3,0	MRN 42	8160	45,1	35,3	17,00	6,4129
		23,45	59,7	115,65	< 3,0	MRN 52	8020	75,0	65,2	17,00	20,8963
		23,25	60,2	114,44	< 3,0	MRN 62	8000	124,6	114,8	17,00	35,8331
	25,0	24,21	57,8	120,00	2,0	MRN 22	4970	19,2	9,4	17,00	1,5348
		26,62	52,6	130,43	< 3,0	MRN 32	7750	23,6	13,8	17,00	1,9888
		24,26	57,7	118,42	< 3,0	MRN 52	12560	75,0	65,2	17,00	21,6073
		25,24	55,5	123,63	< 3,0	MRN 62	16780	124,6	114,8	17,00	38,1707
	28,0	29,32	47,8	141,96	1,9	MRN 22	4770	19,2	9,4	17,00	1,4440
		28,93	48,4	139,66	< 3,0	MRN 32	5550	23,6	13,8	17,00	1,7952
		28,28	49,5	139,06	< 3,0	MRN 42	8920	45,1	35,3	17,00	6,1008
		27,55	50,8	134,68	< 3,0	MRN 52	8090	75,0	65,2	17,00	20,3546
31,5	27,69	50,6	136,25	< 3,0	MRN 62	6000	124,6	114,8	17,00	34,0539	
	30,59	45,8	150,00	0,9	MRN 12	4070	15,8	6,0	17,00	0,3789	
	30,71	45,6	150,00	1,6	MRN 22	5180	19,2	9,4	17,00	1,4772	
	31,33	44,7	157,89	2,5	MRN 32	7920	23,6	13,8	17,00	1,8858	
33,0	30	46,7	147,97	< 3,0	MRN 42	9290	45,1	35,3	17,00	6,2602	
	30,02	46,6	147,22	< 3,0	MRN 52	9610	75,0	65,2	17,00	20,1029	
	30,38	46,1	149,28	< 3,0	MRN 62	7160	124,6	114,8	17,00	33,2259	
	33	42,4	162,16	1,0	MRN 12	4290	15,8	6,0	17,00	0,3685	
35,5	36,47	38,4	177,97	0,8	MRN 12	4700	15,8	6,0	17,00	0,3626	
	34,52	40,6	166,67	1,3	MRN 22	5420	19,2	9,4	17,00	1,4202	
	34,5	40,6	168,75	2,7	MRN 32	7320	23,6	13,8	17,00	1,7221	
	37,39	37,4	185,00	< 3,0	MRN 42	10030	45,1	35,3	17,00	6,0256	
40,0	36,31	38,6	177,27	< 3,0	MRN 52	13530	75,0	65,2	17,00	19,6654	
	37,35	37,5	183,13	< 3,0	MRN 62	16090	124,6	114,8	17,00	31,7360	
	39,72	35,2	191,49	1,3	MRN 22	5380	19,2	9,4	17,00	1,4329	
	36,34	38,5	175,23	1,4	MRN 23	5130	19,5	9,7	17,00	0,9994	
45,0	40,87	34,3	196,88	2,1	MRN 32	8250	23,6	13,8	17,00	1,7600	
	35,86	39	175,00	2,8	MRN 33	6840	23,8	14,0	17,00	1,2294	
	38,12	36,7	187,50	< 3,0	MRN 42	10140	45,1	35,3	17,00	5,8382	
	34,07	41,1	165,91	< 3,0	MRN 43	9670	47,3	37,5	17,00	4,3102	
50,0	40,79	34,3	199,47	< 3,0	MRN 52	14620	75,0	65,2	17,00	19,9025	
	37,28	37,6	179,35	< 3,0	MRN 53	9220	79,6	69,8	17,00	13,8553	
	39,49	35,5	194,70	< 3,0	MRN 62	18170	124,6	114,8	17,00	33,3872	
	38,2	36,7	183,27	< 3,0	MRN 63	7350	130,8	121,0	17,00	22,6869	
50,0	46,78	29,9	224,09	1,1	MRN 22	5550	19,2	9,4	17,00	1,4122	
	44,73	31,3	215,43	1,3	MRN 23	5070	19,5	9,7	17,00	0,9900	
	47,5	29,5	240,00	1,3	MRN 32	9440	23,6	13,8	17,00	1,6310	
	44,2	31,7	217,11	2,5	MRN 33	5900	23,8	14,0	17,00	1,2052	
	45,27	30,9	225,00	< 3,0	MRN 42	10720	45,1	35,3	17,00	5,8675	
	42,59	32,9	206,82	< 3,0	MRN 43	10030	47,3	37,5	17,00	4,2058	
	45,38	30,8	222,97	< 3,0	MRN 52	15630	75,0	65,2	17,00	19,2544	
	47,28	29,6	229,02	< 3,0	MRN 53	8610	79,6	69,8	17,00	13,7108	
	43,31	32,3	213,25	< 3,0	MRN 62	18380	124,6	114,8	17,00	32,6717	
	51,19	27,3	245,00	1,0	MRN 22	5650	19,2	9,4	17,00	1,4027	
	48,74	28,7	242,31	1,7	MRN 32	8530	23,6	13,8	17,00	1,6974	
	50,4	27,8	244,57	< 3,0	MRN 42	11110	45,1	35,3	17,00	5,7968	
49,33	28,4	243,75	< 3,0	MRN 52	15030	75,0	65,2	17,00	19,5092		
53,26	26,3	262,50	< 3,0	MRN 62	18970	124,6	114,8	17,00	31,3694		

## Getriebe - Gearboxes - Riduttori RN

1400 rpm

Selezione Motoriduttore - Geared Motor Selection - Getriebemotorauswahl

P <sub>1</sub> [kW]	i <sub>n</sub>	i <sub>r</sub>	N <sub>2</sub> [rpm]	M <sub>2</sub> [Nm]	FS	Tipo - Size - Größe	F <sub>r2</sub> [N]	MRN [kg]	FRN [kg]	J <sub>m</sub> × 10 <sup>-4</sup>	J <sub>1</sub> × 10 <sup>-4</sup>
0,75	50,0	48,44	28,9	233,94	> 3,0	MRN 63	7670	130,8	121,0	17,00	22,2684
	56,0	55,91	25	270,35	1,1	MRN 23	4970	19,5	9,7	17,00	0,9828
		53,75	26	262,50	1,6	MRN 32	8640	23,6	13,8	17,00	1,6689
		55,31	25,3	271,88	2,1	MRN 33	5500	23,8	14,0	17,00	1,1864
		56,67	24,7	276,32	2,5	MRN 42	11600	45,1	35,3	17,00	5,7318
		54,21	25,8	262,50	> 3,0	MRN 43	9830	47,3	37,5	17,00	4,1359
		57,27	24,4	273,44	> 3,0	MRN 53	8800	79,6	69,8	17,00	13,6244
		59,89	23,4	295,08	> 3,0	MRN 62	19310	124,6	114,8	17,00	30,7868
		58,68	23,9	283,33	> 3,0	MRN 63	7800	130,8	121,0	17,00	22,0179
	63,0	62,66	22,3	302,42	0,8	MRN 22	6040	19,2	9,4	17,00	1,3859
		67,1	20,9	328,13	1,3	MRN 32	9030	23,6	13,8	17,00	1,6180
		66,13	21,2	322,83	> 3,0	MRN 43	10110	47,3	37,5	17,00	4,0833
		61,67	22,7	304,69	> 3,0	MRN 52	15530	75,0	65,2	17,00	19,1667
		71,0	71,57	19,6	341,91	0,9	MRN 23	5100	19,5	9,7	17,00
	70,88		19,8	334,62	1,7	MRN 33	5500	23,8	14,0	17,00	1,1714
70,82	19,8		341,67	1,2	MRN 43	12640	47,3	37,5	17,00	4,0520	
70,6	19,8		336,54	> 3,0	MRN 53	9010	79,6	69,8	17,00	13,5519	
72,33	19,4		349,32	> 3,0	MRN 63	7800	130,8	121,0	17,00	21,8075	
80,0	82,52	17	394,74	2,5	MRN 43	10510	47,3	37,5	17,00	3,7956	
	79,72	17,6	381,43	> 3,0	MRN 63	25090	130,8	121,0	17,00	19,9592	
	88,14	15,9	422,73	0,7	MRN 23	5200	19,5	9,7	17,00	0,9738	
90,0	94,22	14,9	453,13	1,3	MRN 33	5500	23,8	14,0	17,00	1,1594	
	89,6	15,6	429,78	1,2	MRN 43	13650	47,3	37,5	17,00	4,0262	
	89,26	15,7	428,23	> 3,0	MRN 53	8500	79,6	69,8	17,00	13,4907	
	91,45	15,3	439,66	> 3,0	MRN 63	7800	130,8	121,0	17,00	21,6298	
100,0	106,48	13,1	505,00	2,0	MRN 43	10930	47,3	37,5	17,00	3,7770	
	95,68	14,6	457,89	2,5	MRN 53	17820	79,6	69,8	17,00	12,7382	
	105,42	13,3	503,57	> 3,0	MRN 63	22430	130,8	121,0	17,00	19,8591	
112,0	110,89	12,6	530,49	1,1	MRN 33	5500	23,8	14,0	17,00	1,1543	
	117,24	11,9	559,38	> 3,0	MRN 53	7200	79,6	69,8	17,00	13,4396	
125,0	121,33	11,5	577,94	2,3	MRN 53	17330	79,6	69,8	17,00	12,7114	
125,0	120,13	11,7	579,55	> 3,0	MRN 63	7800	130,8	121,0	17,00	21,4811	
140,0	144,64	9,68	690,48	0,8	MRN 33	5500	23,8	14,0	17,00	1,1483	
	132,69	10,6	647,73	1,5	MRN 43	12260	47,3	37,5	17,00	4,0051	
	137,77	10,2	675,00	2,7	MRN 53	7200	79,6	69,8	17,00	13,4179	
	143,08	9,78	689,19	> 3,0	MRN 63	7800	130,8	121,0	17,00	21,4145	
	160,0	160,69	8,71	770,27	1,0	MRN 43	14590	47,3	37,5	17,00	3,9942
150,12		9,33	708,33	2,4	MRN 53	12400	79,6	69,8	17,00	13,4079	
156,94		8,92	750,00	> 3,0	MRN 63	7900	130,8	121,0	17,00	21,3834	
180,0	173,9	8,05	833,33	1,0	MRN 43	14570	47,3	37,5	17,00	3,9843	
	181,54	7,71	850,00	1,6	MRN 53	18220	79,6	69,8	17,00	13,3896	
200,0	192,98	7,25	920,45	2,9	MRN 63	21200	130,8	121,0	17,00	21,3276	
224,0	217	6,45	1052,63	0,8	MRN 43	15210	47,3	37,5	17,00	3,9773	
	229,08	6,11	1100,54	1,2	MRN 53	19100	79,6	69,8	17,00	12,6660	
	217	6,45	1014,71	2,3	MRN 63	26700	130,8	121,0	17,00	21,3029	
250,0	252,39	5,55	1218,75	2,1	MRN 63	22500	130,8	121,0	17,00	19,6541	
315,0	300,91	4,65	1446,43	0,9	MRN 53	19100	79,6	69,8	17,00	12,6544	
	331,53	4,22	1625,00	1,6	MRN 63	22500	130,8	121,0	17,00	19,6213	
355,0	353,6	3,96	1687,50	0,8	MRN 53	19100	79,6	69,8	17,00	12,6493	
400,0	385,28	3,63	1840,91	0,7	MRN 53	19100	79,6	69,8	17,00	12,6469	

## RN Riduttori - Gearboxes - Getriebe

Selezione Motoriduttore - Geared Motor Selection - Getriebemotorauswahl

1400 rpm

P <sub>1</sub> [kW]	i <sub>n</sub>	i <sub>r</sub>	N <sub>2</sub> [rpm]	M <sub>2</sub> [Nm]	FS	Tipo - Size - Größe	F <sub>r2</sub> [N]	MRN [kg]	FRN [kg]	J <sub>m</sub> × 10 <sup>-4</sup>	J <sub>1</sub> × 10 <sup>-4</sup>
0,75	400,0	394,87	3,55	1950,00	1,3	MRN 63	22500	130,8	121,0	17,00	19,6063
	450,0	433,13	3,23	2074,47	1,3	MRN 63	22500	130,8	121,0	17,00	19,5991
	500,0	532,58	2,63	2565,79	1,0	MRN 63	22500	130,8	121,0	17,00	19,5861
	560,0	598,89	2,34	2867,65	0,9	MRN 63	22500	130,8	121,0	17,00	19,5803
1,1	6,3	5,76	243	40,98	> 3,0	MRN 22	3200	21,4	9,4	33,00	2,5855
		5,59	250	40,37	> 3,0	MRN 32	4760	25,8	13,8	33,00	4,8684
		5,74	244	41,33	> 3,0	MRN 42	5030	47,3	35,3	33,00	13,0943
		5,64	248	40,60	> 3,0	MRN 52	7550	77,2	65,2	33,00	37,6347
		5,77	250	40,27	> 3,0	MRN 62	10060	126,8	114,8	33,00	84,0612
	7,1	6,59	212	47,41	2,6	MRN 12	3350	18,0	6,0	33,00	0,8414
		7,37	190	51,41	> 3,0	MRN 22	3450	21,4	9,4	33,00	2,1881
		7,17	195	51,41	> 3,0	MRN 32	5180	25,8	13,8	33,00	3,8232
		7,26	193	52,35	> 3,0	MRN 42	5190	47,3	35,3	33,00	10,7969
		7,46	188	53,72	> 3,0	MRN 52	8250	77,2	65,2	33,00	31,2885
		7,39	189	53,26	> 3,0	MRN 62	9540	126,8	114,8	33,00	68,0211
		7,95	176	57,20	2,3	MRN 12	3470	18,0	6,0	33,00	0,7600
	8,0	7,8	179	55,00	> 3,0	MRN 22	3530	21,4	9,4	33,00	2,2972
		7,9	177	57,32	> 3,0	MRN 32	5410	25,8	13,8	33,00	3,9288
		7,59	185	54,60	> 3,0	MRN 42	5680	47,3	35,3	33,00	11,2674
		7,66	183	55,24	> 3,0	MRN 52	8410	77,2	65,2	33,00	31,9539
		7,97	176	57,48	> 3,0	MRN 62	11380	126,8	114,8	33,00	68,6806
		8,32	168	59,23	2,4	MRN 12	3580	18,0	6,0	33,00	0,6786
		9,07	154	64,39	> 3,0	MRN 22	3690	21,4	9,4	33,00	1,9599
	9,0	8,84	158	63,61	> 3,0	MRN 32	5180	25,8	13,8	33,00	3,2176
		9,08	154	65,27	> 3,0	MRN 42	5660	47,3	35,3	33,00	9,2579
		9,46	148	68,14	> 3,0	MRN 52	8900	77,2	65,2	33,00	27,6749
		9,38	149	67,58	> 3,0	MRN 62	9030	126,8	114,8	33,00	56,8499
		10,11	138	71,74	2,1	MRN 12	3490	18,0	6,0	33,00	0,5849
		9,98	140	70,28	> 3,0	MRN 22	3850	21,4	9,4	33,00	2,0120
		10,13	138	73,33	> 3,0	MRN 32	5890	25,8	13,8	33,00	3,2515
	10,0	9,6	146	69,00	> 3,0	MRN 42	6200	47,3	35,3	33,00	9,6555
		10,13	138	73,12	> 3,0	MRN 52	9280	77,2	65,2	33,00	28,0395
		10,54	133	75,86	> 3,0	MRN 62	12550	126,8	114,8	33,00	58,6662
		11,33	124	79,44	> 3,0	MRN 22	3890	21,4	9,4	33,00	1,7848
		11,06	127	79,86	> 3,0	MRN 32	4550	25,8	13,8	33,00	2,7466
		11,55	121	83,42	> 3,0	MRN 42	6170	47,3	35,3	33,00	8,0995
		11,45	122	82,37	> 3,0	MRN 52	8400	77,2	65,2	33,00	25,5151
	12,5	11,36	123	81,77	> 3,0	MRN 62	5620	126,8	114,8	33,00	50,1639
		12,19	115	89,38	1,5	MRN 12	3470	18,0	6,0	33,00	0,5416
		12,29	114	87,24	2,6	MRN 22	4140	21,4	9,4	33,00	1,8436
		12,49	112	90,87	> 3,0	MRN 32	6330	25,8	13,8	33,00	2,8412
		12	117	86,52	> 3,0	MRN 42	6720	47,3	35,3	33,00	8,5274
		12,85	109	92,59	> 3,0	MRN 52	10080	77,2	65,2	33,00	25,6545
		13,17	106	95,53	1,7	MRN 12	3450	18,0	6,0	33,00	0,4982
	14,0	14,51	96,5	103,13	2,9	MRN 22	3720	21,4	9,4	33,00	1,6479
		14,18	98,8	102,41	> 3,0	MRN 32	4700	25,8	13,8	33,00	2,3720
		14,09	99,3	101,20	> 3,0	MRN 42	6810	47,3	35,3	33,00	7,4107
		14,12	99,2	101,78	> 3,0	MRN 52	8470	77,2	65,2	33,00	23,7029
14		100	100,75	> 3,0	MRN 62	5450	126,8	114,8	33,00	44,5468	
16,0		15,87	88,2	118,46	1,2	MRN 12	3450	18,0	6,0	33,00	0,4722

## Getriebe - Gearboxes - Riduttori RN

1400 rpm

Selezione Motoriduttore - Geared Motor Selection - Getriebemotorauswahl

P <sub>1</sub> [kW]	i <sub>n</sub>	i <sub>r</sub>	N <sub>2</sub> [rpm]	M <sub>2</sub> [Nm]	FS	Tipo - Size - Größe	F <sub>r2</sub> [N]	MRN [kg]	FRN [kg]	J <sub>m</sub> × 10 <sup>-4</sup>	J <sub>1</sub> × 10 <sup>-4</sup>	
1,1	16,0	15,36	91,2	110,00	2,1	MRN 22	4480	21,4	9,4	33,00	1,7103	
		15,63	89,6	112,89	> 3,0	MRN 32	6830	25,8	13,8	33,00	2,5063	
		15,27	91,7	110,00	> 3,0	MRN 42	7330	47,3	35,3	33,00	7,6485	
		15,56	90	111,90	> 3,0	MRN 52	10780	77,2	65,2	33,00	24,1384	
	18,0	16,19	86,4	116,75	> 3,0	MRN 62	11630	126,8	114,8	33,00	46,1997	
			16,65	84,1	121,00	1,4	MRN 12	3560	18,0	6,0	33,00	0,4462
			17,87	78,4	126,30	2,5	MRN 22	3590	21,4	9,4	33,00	1,5647
			18,84	74,3	134,44	> 3,0	MRN 32	4860	25,8	13,8	33,00	2,0717
		17,59	79,6	126,30	> 3,0	MRN 42	7410	47,3	35,3	33,00	6,8426	
			17,85	78,4	128,99	> 3,0	MRN 52	8680	77,2	65,2	33,00	22,1741
			17,7	79,1	127,54	> 3,0	MRN 62	3100	126,8	114,8	33,00	39,8027
			20,0	20,29	69	143,85	1,2	MRN 12	3710	18,0	6,0	33,00
19,66	71,2	140,56		1,6	MRN 22	4810	21,4	9,4	33,00	1,6024		
20,03	69,9	143,00		2,7	MRN 32	7400	25,8	13,8	33,00	2,2256		
19,19	73	137,79		> 3,0	MRN 52	11580	77,2	65,2	33,00	22,7969		
19,96	70,1	143,51	> 3,0	MRN 62	15790	126,8	114,8	33,00	41,9382			
	22,4	22,67	61,8	162,38	1,9	MRN 22	3800	21,4	9,4	33,00	1,4958	
		22,18	63,1	159,21	> 3,0	MRN 32	5000	25,8	13,8	33,00	1,9456	
		22,69	61,7	164,13	> 3,0	MRN 42	8160	47,3	35,3	33,00	6,4129	
	23,45	59,7	169,63	> 3,0	MRN 52	8020	77,2	65,2	33,00	20,8963		
23,25		60,2	167,84	> 3,0	MRN 62	8000	126,8	114,8	33,00	35,8331		
25,0		24,21	57,8	176,00	1,4	MRN 22	4970	21,4	9,4	33,00	1,5348	
		26,62	52,6	191,30	2,1	MRN 32	7750	25,8	13,8	33,00	1,9888	
24,26	57,7	173,68	> 3,0	MRN 52	12560	77,2	65,2	33,00	21,6073			
	25,24	55,5	181,32	> 3,0	MRN 62	16780	126,8	114,8	33,00	38,1707		
	28,0	29,32	47,8	208,21	1,3	MRN 22	4770	21,4	9,4	33,00	1,4440	
		28,93	48,4	204,83	2,6	MRN 32	5550	25,8	13,8	33,00	1,7952	
		28,28	49,5	203,96	> 3,0	MRN 42	8920	47,3	35,3	33,00	6,1008	
27,55	50,8	197,53	> 3,0	MRN 52	8090	77,2	65,2	33,00	20,3546			
	27,69	50,6	199,83	> 3,0	MRN 62	6000	126,8	114,8	33,00	34,0539		
	31,5	30,71	45,6	220,00	1,1	MRN 22	5180	21,4	9,4	33,00	1,4772	
		31,33	44,7	231,58	1,7	MRN 32	7920	25,8	13,8	33,00	1,8858	
		30	46,7	217,03	> 3,0	MRN 42	9290	47,3	35,3	33,00	6,2602	
30,02	46,6	215,93	> 3,0	MRN 52	9610	77,2	65,2	33,00	20,1029			
	30,38	46,1	218,94	> 3,0	MRN 62	7160	126,8	114,8	33,00	33,2259		
	35,5	34,5	40,6	247,50	1,8	MRN 32	7320	25,8	13,8	33,00	1,7221	
		37,39	37,4	271,33	2,7	MRN 42	10030	47,3	35,3	33,00	6,0256	
		36,31	38,6	260,00	> 3,0	MRN 52	13530	77,2	65,2	33,00	19,6654	
37,35	37,5	268,59	> 3,0	MRN 62	16090	126,8	114,8	33,00	31,7360			
	40,0	40,87	34,3	288,75	1,5	MRN 32	8250	25,8	13,8	33,00	1,7600	
		35,86	39	256,67	1,9	MRN 33	6840	26,0	14,0	33,00	1,2294	
		38,12	36,7	275,00	2,4	MRN 42	10140	47,3	35,3	33,00	5,8382	
	34,07	41,1	243,33	3,0	MRN 43	9670	49,5	37,5	33,00	4,3102		
40,79	34,3	292,55	> 3,0	MRN 52	14620	77,2	65,2	33,00	19,9025			
37,28	37,6	263,04	> 3,0	MRN 53	9220	81,8	69,8	33,00	13,8553			
39,49	35,5	285,56	> 3,0	MRN 62	18170	126,8	114,8	33,00	33,3872			
38,2	36,7	268,80	> 3,0	MRN 63	7350	133,0	121,0	33,00	22,6869			
45,0	47,5	29,5	352,00	0,9	MRN 32	9440	25,8	13,8	33,00	1,6310		
	44,2	31,7	318,42	1,7	MRN 33	5900	26,0	14,0	33,00	1,2052		
	45,27	30,9	330,00	2,3	MRN 42	10720	47,3	35,3	33,00	5,8675		



## RN Riduttori - Gearboxes - Getriebe

Selezione Motoriduttore - Geared Motor Selection - Getriebemotorauswahl

1400 rpm

P <sub>1</sub> [kW]	i <sub>n</sub>	i <sub>r</sub>	N <sub>2</sub> [rpm]	M <sub>2</sub> [Nm]	FS	Tipo - Size - Größe	F <sub>r2</sub> [N]	MRN [kg]	FRN [kg]	J <sub>m</sub> × 10 <sup>-4</sup>	J <sub>1</sub> × 10 <sup>-4</sup>
1,1	45,0	42,59	32,9	303,33	3,0	MRN 43	10030	49,5	37,5	33,00	4,2058
		45,38	30,8	327,03	> 3,0	MRN 52	15630	77,2	65,2	33,00	19,2544
		47,28	29,6	335,89	> 3,0	MRN 53	8610	81,8	69,8	33,00	13,7108
		43,31	32,3	312,77	> 3,0	MRN 62	18380	126,8	114,8	33,00	32,6717
	50,0	48,74	28,7	355,38	1,2	MRN 32	8530	25,8	13,8	33,00	1,6974
		50,4	27,8	358,70	2,1	MRN 42	11110	47,3	35,3	33,00	5,7968
		49,33	28,4	357,50	> 3,0	MRN 52	15030	77,2	65,2	33,00	19,5092
		53,26	26,3	385,00	> 3,0	MRN 62	18970	126,8	114,8	33,00	31,3694
		48,44	28,9	343,12	> 3,0	MRN 63	7670	133,0	121,0	33,00	22,2684
		56,0	53,75	26	385,00	1,1	MRN 32	8640	25,8	13,8	33,00
	55,31		25,3	398,75	1,5	MRN 33	5500	26,0	14,0	33,00	1,1864
	56,67		24,7	405,26	1,7	MRN 42	11600	47,3	35,3	33,00	5,7318
	54,21		25,8	385,00	2,5	MRN 43	9830	49,5	37,5	33,00	4,1359
	57,27		24,4	401,04	> 3,0	MRN 53	8800	81,8	69,8	33,00	13,6244
	59,89		23,4	432,79	> 3,0	MRN 62	19310	126,8	114,8	33,00	30,7868
	58,68		23,9	415,56	> 3,0	MRN 63	7800	133,0	121,0	33,00	22,0179
	63,0		66,13	21,2	473,48	2,1	MRN 43	10110	49,5	37,5	33,00
		61,67	22,7	446,88	2,9	MRN 52	15530	77,2	65,2	33,00	19,1667
		71,0	70,88	19,8	490,77	1,2	MRN 33	5500	26,0	14,0	33,00
	70,6		19,8	493,59	> 3,0	MRN 53	9010	81,8	69,8	33,00	13,5519
	72,33		19,4	512,33	> 3,0	MRN 63	7800	133,0	121,0	33,00	21,8075
	80,0	82,52	17	578,95	1,7	MRN 43	10510	49,5	37,5	33,00	3,7956
		79,72	17,6	559,43	> 3,0	MRN 63	25090	133,0	121,0	33,00	19,9592
	90,0	89,26	15,7	628,06	2,8	MRN 53	8500	81,8	69,8	33,00	13,4907
		91,45	15,3	644,83	> 3,0	MRN 63	7800	133,0	121,0	33,00	21,6298
	100,0	106,48	13,1	740,67	1,4	MRN 43	10930	49,5	37,5	33,00	3,7770
		95,68	14,6	671,58	1,7	MRN 53	17820	81,8	69,8	33,00	12,7382
		105,42	13,3	738,57	> 3,0	MRN 63	22430	133,0	121,0	33,00	19,8591
	112,0	117,24	11,9	820,42	2,2	MRN 53	7200	81,8	69,8	33,00	13,4396
	125,0	121,33	11,5	847,65	1,5	MRN 53	17330	81,8	69,8	33,00	12,7114
		120,13	11,7	850,00	> 3,0	MRN 63	7800	133,0	121,0	33,00	21,4811
	140,0	132,69	10,6	950,00	1,0	MRN 43	12260	49,5	37,5	33,00	4,0051
		137,77	10,2	990,00	1,8	MRN 53	7200	81,8	69,8	33,00	13,4179
		143,08	9,78	1010,81	> 3,0	MRN 63	7800	133,0	121,0	33,00	21,4145
	160,0	150,12	9,33	1038,89	1,6	MRN 53	12400	81,8	69,8	33,00	13,4079
		156,94	8,92	1100,00	3,0	MRN 63	7900	133,0	121,0	33,00	21,3834
	180,0	181,54	7,71	1246,67	1,1	MRN 53	18220	81,8	69,8	33,00	13,3896
	200,0	192,98	7,25	1350,00	2,0	MRN 63	21200	133,0	121,0	33,00	21,3276
	224,0	229,08	6,11	1614,13	0,8	MRN 53	19100	81,8	69,8	33,00	12,6660
		217	6,45	1488,24	1,5	MRN 63	26700	133,0	121,0	33,00	21,3029
	250,0	252,39	5,55	1787,50	1,5	MRN 63	22500	133,0	121,0	33,00	19,6541
	315,0	331,53	4,22	2383,33	1,1	MRN 63	22500	133,0	121,0	33,00	19,6213
400,0	394,87	3,55	2860,00	0,9	MRN 63	22500	133,0	121,0	33,00	19,6063	
450,0	433,13	3,23	3042,55	0,9	MRN 63	22500	133,0	121,0	33,00	19,5991	
1,5	6,3	5,76	243	55,88	> 3,0	MRN 22	3200	22,9	9,4	40,00	2,5855
		5,59	250	55,05	> 3,0	MRN 32	4760	27,3	13,8	40,00	4,8684
		5,74	244	56,35	> 3,0	MRN 42	5030	48,8	35,3	40,00	13,0943
		5,64	248	55,37	> 3,0	MRN 52	7550	78,7	65,2	40,00	37,6347
		5,77	250	54,91	> 3,0	MRN 62	10060	128,3	114,8	40,00	84,0612
	7,1	6,59	212	64,66	1,9	MRN 12	3350	19,5	6,0	40,00	0,8414

## Getriebe - Gearboxes - Riduttori RN

1400 rpm

Selezione Motoriduttore - Geared Motor Selection - Getriebemotorauswahl

$P_1$ [kW]	$i_n$	$i_r$	$N_2$ [rpm]	$M_2$ [Nm]	FS	Tipo - Size - Größe	$F_{r2}$ [N]	MRN [kg]	FRN [kg]	$J_m$ $\times 10^{-4}$	$J_1$ $\times 10^{-4}$
1,5	7,1	7,37	190	70,11	>3,0	MRN 22	3450	22,9	9,4	40,00	2,1881
		7,17	195	70,11	> 3.0	MRN 32	5180	27,3	13,8	40,00	3,8232
		7,26	193	71,39	> 3.0	MRN 42	5190	48,8	35,3	40,00	10,7969
		7,46	188	73,26	> 3.0	MRN 52	8250	78,7	65,2	40,00	31,2885
		7,39	189	72,63	> 3.0	MRN 62	9540	128,3	114,8	40,00	68,0211
		7,95	176	78,00	1,7	MRN 12	3470	19,5	6,0	40,00	0,7600
	8,0	7,8	179	75,00	2,9	MRN 22	3530	22,9	9,4	40,00	2,2972
		7,9	177	78,17	> 3.0	MRN 32	5410	27,3	13,8	40,00	3,9288
		7,59	185	74,46	> 3.0	MRN 42	5680	48,8	35,3	40,00	11,2674
		7,66	183	75,33	> 3.0	MRN 52	8410	78,7	65,2	40,00	31,9539
		7,97	176	78,38	> 3.0	MRN 62	11380	128,3	114,8	40,00	68,6806
		8,32	168	80,77	1,7	MRN 12	3580	19,5	6,0	40,00	0,6786
9,0	9,07	154	87,80	2,7	MRN 22	3690	22,9	9,4	40,00	1,9599	
	8,84	158	86,75	> 3.0	MRN 32	5180	27,3	13,8	40,00	3,2176	
	9,08	154	89,00	> 3.0	MRN 42	5660	48,8	35,3	40,00	9,2579	
	9,46	148	92,92	> 3.0	MRN 52	8900	78,7	65,2	40,00	27,6749	
	9,38	149	92,16	> 3.0	MRN 62	9030	128,3	114,8	40,00	56,8499	
	10,11	138	97,83	1,5	MRN 12	3490	19,5	6,0	40,00	0,5849	
10,0	9,98	140	95,83	2,4	MRN 22	3850	22,9	9,4	40,00	2,0120	
	10,13	138	100,00	> 3.0	MRN 32	5890	27,3	13,8	40,00	3,2515	
	9,6	146	94,09	> 3.0	MRN 42	6200	48,8	35,3	40,00	9,6555	
	10,13	138	99,71	> 3.0	MRN 52	9280	78,7	65,2	40,00	28,0395	
	10,54	133	103,45	> 3.0	MRN 62	12550	128,3	114,8	40,00	58,6662	
	11,33	124	108,33	2,4	MRN 22	3890	22,9	9,4	40,00	1,7848	
11,2	11,06	127	108,90	> 3.0	MRN 32	4550	27,3	13,8	40,00	2,7466	
	11,55	121	113,75	> 3.0	MRN 42	6170	48,8	35,3	40,00	8,0995	
	11,45	122	112,32	> 3.0	MRN 52	8400	78,7	65,2	40,00	25,5151	
	11,36	123	111,51	> 3.0	MRN 62	5620	128,3	114,8	40,00	50,1639	
	12,19	115	121,88	1,1	MRN 12	3470	19,5	6,0	40,00	0,5416	
	12,29	114	118,97	1,9	MRN 22	4140	22,9	9,4	40,00	1,8436	
12,5	12,49	112	123,91	> 3.0	MRN 32	6330	27,3	13,8	40,00	2,8412	
	12	117	117,98	> 3.0	MRN 42	6720	48,8	35,3	40,00	8,5274	
	12,85	109	126,26	> 3.0	MRN 52	10080	78,7	65,2	40,00	25,6545	
	13,17	106	130,26	1,3	MRN 12	3450	19,5	6,0	40,00	0,4982	
	14,51	96,5	140,63	2,1	MRN 22	3720	22,9	9,4	40,00	1,6479	
	14,18	98,8	139,66	> 3.0	MRN 32	4700	27,3	13,8	40,00	2,3720	
14,0	14,09	99,3	138,00	> 3.0	MRN 42	6810	48,8	35,3	40,00	7,4107	
	14,12	99,2	138,79	> 3.0	MRN 52	8470	78,7	65,2	40,00	23,7029	
	14	100	137,39	> 3.0	MRN 62	5450	128,3	114,8	40,00	44,5468	
	15,87	88,2	161,54	0,9	MRN 12	3450	19,5	6,0	40,00	0,4722	
	15,36	91,2	150,00	1,5	MRN 22	4480	22,9	9,4	40,00	1,7103	
	15,63	89,6	153,95	2,5	MRN 32	6830	27,3	13,8	40,00	2,5063	
16,0	15,27	91,7	150,00	> 3.0	MRN 42	7330	48,8	35,3	40,00	7,6485	
	15,56	90	152,59	> 3.0	MRN 52	10780	78,7	65,2	40,00	24,1384	
	16,19	86,4	159,20	> 3.0	MRN 62	11630	128,3	114,8	40,00	46,1997	
	16,65	84,1	165,00	1,0	MRN 12	3560	19,5	6,0	40,00	0,4462	
	17,87	78,4	172,22	1,8	MRN 22	3590	22,9	9,4	40,00	1,5647	
	18,84	74,3	183,33	3,0	MRN 32	4860	27,3	13,8	40,00	2,0717	
18,0	17,59	79,6	172,22	> 3.0	MRN 42	7410	48,8	35,3	40,00	6,8426	
	17,85	78,4	175,90	> 3.0	MRN 52	8680	78,7	65,2	40,00	22,1741	

## RN Riduttori - Gearboxes - Getriebe

Selezione Motoriduttore - Geared Motor Selection - Getriebemotorauswahl

1400 rpm

P <sub>1</sub> [kW]	i <sub>n</sub>	i <sub>r</sub>	N <sub>2</sub> [rpm]	M <sub>2</sub> [Nm]	FS	Tipo - Size - Größe	F <sub>r2</sub> [N]	MRN [kg]	FRN [kg]	J <sub>m</sub> × 10 <sup>-4</sup>	J <sub>1</sub> × 10 <sup>-4</sup>	
1,5	18,0	17,7	79,1	173,91	> 3,0	MRN 62	3100	128,3	114,8	40,00	39,8027	
	20,0	20,29	69	196,15	0,9	MRN 12	3710	19,5	6,0	40,00	0,4149	
22,4		19,66	71,2	191,67	1,2	MRN 22	4810	22,9	9,4	40,00	1,6024	
		20,03	69,9	195,00	2,0	MRN 32	7400	27,3	13,8	40,00	2,2256	
		19,19	73	187,89	> 3,0	MRN 52	11580	78,7	65,2	40,00	22,7969	
		19,96	70,1	195,69	> 3,0	MRN 62	15790	128,3	114,8	40,00	41,9382	
		22,67	61,8	221,43	1,4	MRN 22	3800	22,9	9,4	40,00	1,4958	
		22,18	63,1	217,11	2,5	MRN 32	5000	27,3	13,8	40,00	1,9456	
		22,69	61,7	223,81	> 3,0	MRN 42	8160	48,8	35,3	40,00	6,4129	
		23,45	59,7	231,31	> 3,0	MRN 52	8020	78,7	65,2	40,00	20,8963	
		23,25	60,2	228,87	> 3,0	MRN 62	8000	128,3	114,8	40,00	35,8331	
		25,0	24,21	57,8	240,00	1,0	MRN 22	4970	22,9	9,4	40,00	1,5348
28,0		26,62	52,6	260,87	1,5	MRN 32	7750	27,3	13,8	40,00	1,9888	
		24,26	57,7	236,84	> 3,0	MRN 52	12560	78,7	65,2	40,00	21,6073	
		25,24	55,5	247,25	> 3,0	MRN 62	16780	128,3	114,8	40,00	38,1707	
		29,32	47,8	283,93	0,9	MRN 22	4770	22,9	9,4	40,00	1,4440	
		28,93	48,4	279,31	1,9	MRN 32	5550	27,3	13,8	40,00	1,7952	
		28,28	49,5	278,13	> 3,0	MRN 42	8920	48,8	35,3	40,00	6,1008	
		27,55	50,8	269,35	> 3,0	MRN 52	8090	78,7	65,2	40,00	20,3546	
		27,69	50,6	272,50	> 3,0	MRN 62	6000	128,3	114,8	40,00	34,0539	
		31,5	30,71	45,6	300,00	0,8	MRN 22	5180	22,9	9,4	40,00	1,4772
			31,33	44,7	315,79	1,3	MRN 32	7920	27,3	13,8	40,00	1,8858
35,5		30	46,7	295,95	2,5	MRN 42	9290	48,8	35,3	40,00	6,2602	
		30,02	46,6	294,44	> 3,0	MRN 52	9610	78,7	65,2	40,00	20,1029	
		30,38	46,1	298,56	> 3,0	MRN 62	7160	128,3	114,8	40,00	33,2259	
		34,5	40,6	337,50	1,3	MRN 32	7320	27,3	13,8	40,00	1,7221	
		37,39	37,4	370,00	2,0	MRN 42	10030	48,8	35,3	40,00	6,0256	
		36,31	38,6	354,55	> 3,0	MRN 52	13530	78,7	65,2	40,00	19,6654	
		37,35	37,5	366,26	> 3,0	MRN 62	16090	128,3	114,8	40,00	31,7360	
		40,0	40,87	34,3	393,75	1,1	MRN 32	8250	27,3	13,8	40,00	1,7600
			35,86	39	350,00	1,4	MRN 33	6840	27,5	14,0	40,00	1,2294
			38,12	36,7	375,00	1,7	MRN 42	10140	48,8	35,3	40,00	5,8382
45,0		34,07	41,1	331,82	2,2	MRN 43	9670	51,0	37,5	40,00	4,3102	
		40,79	34,3	398,94	> 3,0	MRN 52	14620	78,7	65,2	40,00	19,9025	
		37,28	37,6	358,70	4,6	MRN 53	9220	83,3	69,8	40,00	13,8553	
		39,49	35,5	389,40	8,3	MRN 62	18170	128,3	114,8	40,00	33,3872	
			38,2	36,7	366,54	8,9	MRN 63	7350	134,5	121,0	40,00	22,6869
		44,2	31,7	434,21	1,3	MRN 33	5900	27,5	14,0	40,00	1,2052	
		45,27	30,9	450,00	1,7	MRN 42	10720	48,8	35,3	40,00	5,8675	
		42,59	32,9	413,64	2,2	MRN 43	10030	51,0	37,5	40,00	4,2058	
		45,38	30,8	445,95	2,5	MRN 52	15630	78,7	65,2	40,00	19,2544	
		47,28	29,6	458,04	3,7	MRN 53	8610	83,3	69,8	40,00	13,7108	
50,0		43,31	32,3	426,51	5,5	MRN 62	18380	128,3	114,8	40,00	32,6717	
		48,74	28,7	484,62	0,9	MRN 32	8530	27,3	13,8	40,00	1,6974	
		50,4	27,8	489,13	1,5	MRN 42	11110	48,8	35,3	40,00	5,7968	
		49,33	28,4	487,50	2,7	MRN 52	15030	78,7	65,2	40,00	19,5092	
		53,26	26,3	525,00	4,5	MRN 62	18970	128,3	114,8	40,00	31,3694	
		48,44	28,9	467,89	7,3	MRN 63	7670	134,5	121,0	40,00	22,2684	
		56,0	53,75	26	525,00	0,8	MRN 32	8640	27,3	13,8	40,00	1,6689
			55,31	25,3	543,75	1,1	MRN 33	5500	27,5	14,0	40,00	1,1864

## Getriebe - Gearboxes - Riduttori RN

1400 rpm

Selezione Motoriduttore - Geared Motor Selection - Getriebemotorauswahl

P <sub>1</sub> [kW]	i <sub>n</sub>	i <sub>r</sub>	N <sub>2</sub> [rpm]	M <sub>2</sub> [Nm]	FS	Tipo - Size - Größe	F <sub>r2</sub> [N]	MRN [kg]	FRN [kg]	J <sub>m</sub> × 10 <sup>-4</sup>	J <sub>1</sub> × 10 <sup>-4</sup>
1,5	56,0	56,67	24,7	552,63	1,3	MRN 42	11600	48,8	35,3	40,00	5,7318
		54,21	25,8	525,00	1,9	MRN 43	9830	51,0	37,5	40,00	4,1359
		57,27	24,4	546,88	> 3,0	MRN 53	8800	83,3	69,8	40,00	13,6244
		59,89	23,4	590,16	> 3,0	MRN 62	19310	128,3	114,8	40,00	30,7868
		58,68	23,9	566,67	> 3,0	MRN 63	7800	134,5	121,0	40,00	22,0179
	63,0	66,13	21,2	645,65	1,5	MRN 43	10110	51,0	37,5	40,00	4,0833
		61,67	22,7	609,38	2,1	MRN 52	15530	78,7	65,2	40,00	19,1667
	71,0	70,88	19,8	669,23	0,9	MRN 33	5500	27,5	14,0	40,00	1,1714
		70,6	19,8	673,08	2,6	MRN 53	9010	83,3	69,8	40,00	13,5519
	80,0	72,33	19,4	698,63	> 3,0	MRN 63	7800	134,5	121,0	40,00	21,8075
		82,52	17	789,47	1,3	MRN 43	10510	51,0	37,5	40,00	3,7956
		79,72	17,6	762,86	2,3	MRN 63	25090	134,5	121,0	40,00	19,9592
	90,0	89,26	15,7	856,45	2,1	MRN 53	8500	83,3	69,8	40,00	13,4907
		91,45	15,3	879,31	> 3,0	MRN 63	7800	134,5	121,0	40,00	21,6298
	100,0	106,48	13,1	1010,00	1,0	MRN 43	10930	51,0	37,5	40,00	3,7770
		95,68	14,6	915,79	1,3	MRN 53	17820	83,3	69,8	40,00	12,7382
		105,42	13,3	1007,14	2,3	MRN 63	22430	134,5	121,0	40,00	19,8591
	112,0	117,24	11,9	1118,75	1,6	MRN 53	7200	83,3	69,8	40,00	13,4396
	125,0	121,33	11,5	1155,88	1,1	MRN 53	17330	83,3	69,8	40,00	12,7114
		120,13	11,7	1159,09	2,9	MRN 63	7800	134,5	121,0	40,00	21,4811
	140,0	132,69	10,6	1295,45	0,7	MRN 43	12260	51,0	37,5	40,00	4,0051
		137,77	10,2	1350,00	1,3	MRN 53	7200	83,3	69,8	40,00	13,4179
		143,08	9,78	1378,38	2,5	MRN 63	7800	134,5	121,0	40,00	21,4145
	160,0	150,12	9,33	1416,67	1,2	MRN 53	12400	83,3	69,8	40,00	13,4079
		156,94	8,92	1500,00	2,2	MRN 63	7900	134,5	121,0	40,00	21,3834
	180,0	181,54	7,71	1700,00	0,8	MRN 53	18220	83,3	69,8	40,00	13,3896
	200,0	192,98	7,25	1840,91	1,5	MRN 63	21200	134,5	121,0	40,00	21,3276
	224,0	217	6,45	2029,41	1,1	MRN 63	26700	134,5	121,0	40,00	21,3029
250,0	252,39	5,55	2437,50	1,1	MRN 63	22500	134,5	121,0	40,00	19,6541	
315,0	331,53	4,22	3250,00	0,8	MRN 63	22500	134,5	121,0	40,00	19,6213	
2,2	6,3	5,76	243	81,96	2,3	MRN 22	3200	28,4	9,4	75,00	2,5855
		5,59	250	80,73	> 3,0	MRN 32	4760	32,8	13,8	75,00	4,8684
		5,74	244	82,65	> 3,0	MRN 42	5030	54,3	35,3	75,00	13,0943
		5,64	248	81,21	> 3,0	MRN 52	7550	84,2	65,2	75,00	37,6347
		5,77	250	80,53	> 3,0	MRN 62	10060	133,8	114,8	75,00	84,0612
	7,1	7,37	190	102,83	2,1	MRN 22	3450	28,4	9,4	75,00	2,1881
		7,17	195	102,83	> 3,0	MRN 32	5180	32,8	13,8	75,00	3,8232
		7,26	193	104,70	> 3,0	MRN 42	5190	54,3	35,3	75,00	10,7969
		7,46	188	107,44	> 3,0	MRN 52	8250	84,2	65,2	75,00	31,2885
		7,39	189	106,52	> 3,0	MRN 62	9540	133,8	114,8	75,00	68,0211
	8,0	7,8	179	110,00	2,0	MRN 22	3530	28,4	9,4	75,00	2,2972
		7,9	177	114,65	> 3,0	MRN 32	5410	32,8	13,8	75,00	3,9288
		7,59	185	109,21	> 3,0	MRN 42	5680	54,3	35,3	75,00	11,2674
		7,66	183	110,48	> 3,0	MRN 52	8410	84,2	65,2	75,00	31,9539
		7,97	176	114,96	> 3,0	MRN 62	11380	133,8	114,8	75,00	68,6806
	9,0	9,07	154	128,78	1,9	MRN 22	3690	28,4	9,4	75,00	1,9599
		8,84	158	127,23	> 3,0	MRN 32	5180	32,8	13,8	75,00	3,2176
		9,08	154	130,53	> 3,0	MRN 42	5660	54,3	35,3	75,00	9,2579
		9,46	148	136,28	> 3,0	MRN 52	8900	84,2	65,2	75,00	27,6749
		9,38	149	135,17	> 3,0	MRN 62	9030	133,8	114,8	75,00	56,8499

## RN Riduttori - Gearboxes - Getriebe

Selezione Motoriduttore - Geared Motor Selection - Getriebemotorauswahl

1400 rpm

P <sub>1</sub> [kW]	i <sub>n</sub>	i <sub>r</sub>	N <sub>2</sub> [rpm]	M <sub>2</sub> [Nm]	FS	Tipo - Size - Größe	F <sub>r2</sub> [N]	MRN [kg]	FRN [kg]	J <sub>m</sub> × 10 <sup>-4</sup>	J <sub>1</sub> × 10 <sup>-4</sup>	
2,2	10,0	9,98	140	140,56	1,6	MRN 22	3850	28,4	9,4	75,00	2,0120	
		10,13	138	146,67	2,6	MRN 32	5890	32,8	13,8	75,00	3,2515	
2,2	10,0	9,6	146	138,00	> 3,0	MRN 42	6200	54,3	35,3	75,00	9,6555	
		10,13	138	146,24	> 3,0	MRN 52	9280	84,2	65,2	75,00	28,0395	
		10,54	133	151,72	> 3,0	MRN 62	12550	133,8	114,8	75,00	58,6662	
		11,2	11,33	124	158,89	1,6	MRN 22	3890	28,4	9,4	75,00	1,7848
		11,06	127	159,73	> 3,0	MRN 32	4550	32,8	13,8	75,00	2,7466	
11,2	11,06	11,55	121	166,83	> 3,0	MRN 42	6170	54,3	35,3	75,00	8,0995	
		11,45	122	164,73	> 3,0	MRN 52	8400	84,2	65,2	75,00	25,5151	
		11,36	123	163,55	> 3,0	MRN 62	5620	133,8	114,8	75,00	50,1639	
		12,5	12,29	114	174,48	1,3	MRN 22	4140	28,4	9,4	75,00	1,8436
12,5	12,49	112	181,74	2,1	MRN 32	6330	32,8	13,8	75,00	2,8412		
		12	117	173,03	> 3,0	MRN 42	6720	54,3	35,3	75,00	8,5274	
		12,85	109	185,18	> 3,0	MRN 52	10080	84,2	65,2	75,00	25,6545	
14,0	14,51	96,5	206,25	1,5	MRN 22	3720	28,4	9,4	75,00	1,6479		
		14,18	98,8	204,83	2,6	MRN 32	4700	32,8	13,8	75,00	2,3720	
		14,09	99,3	202,40	> 3,0	MRN 42	6810	54,3	35,3	75,00	7,4107	
		14,12	99,2	203,56	> 3,0	MRN 52	8470	84,2	65,2	75,00	23,7029	
16,0	14	100	201,51	> 3,0	MRN 62	5450	133,8	114,8	75,00	44,5468		
		16,0	15,36	91,2	220,00	1,0	MRN 22	4480	28,4	9,4	75,00	1,7103
		15,63	89,6	225,79	1,7	MRN 32	6830	32,8	13,8	75,00	2,5063	
		15,27	91,7	220,00	> 3,0	MRN 42	7330	54,3	35,3	75,00	7,6485	
		15,56	90	223,79	> 3,0	MRN 52	10780	84,2	65,2	75,00	24,1384	
18,0	16,19	86,4	233,49	> 3,0	MRN 62	11630	133,8	114,8	75,00	46,1997		
		18,0	17,87	78,4	252,59	1,2	MRN 22	3590	28,4	9,4	75,00	1,5647
		18,84	74,3	268,89	2,0	MRN 32	4860	32,8	13,8	75,00	2,0717	
		17,59	79,6	252,59	> 3,0	MRN 42	7410	54,3	35,3	75,00	6,8426	
		17,85	78,4	257,99	> 3,0	MRN 52	8680	84,2	65,2	75,00	22,1741	
20,0	17,7	79,1	255,07	> 3,0	MRN 62	3100	133,8	114,8	75,00	39,8027		
		20,0	20,03	69,9	286,00	1,4	MRN 32	7400	32,8	13,8	75,00	2,2256
		19,19	73	275,58	> 3,0	MRN 52	11580	84,2	65,2	75,00	22,7969	
		19,96	70,1	287,01	> 3,0	MRN 62	15790	133,8	114,8	75,00	41,9382	
22,4	22,18	63,1	318,42	> 3,0	MRN 32	5000	32,8	13,8	75,00	1,9456		
		22,69	61,7	328,25	2,9	MRN 42	8160	54,3	35,3	75,00	6,4129	
		23,45	59,7	339,25	> 3,0	MRN 52	8020	84,2	65,2	75,00	20,8963	
		23,25	60,2	335,68	> 3,0	MRN 62	8000	133,8	114,8	75,00	35,8331	
		25,0	26,62	52,6	382,61	1,0	MRN 32	7750	32,8	13,8	75,00	1,9888
25,0	24,26	57,7	347,37	> 3,0	MRN 52	12560	84,2	65,2	75,00	21,6073		
		25,24	55,5	362,64	> 3,0	MRN 62	16780	133,8	114,8	75,00	38,1707	
		28,0	28,93	48,4	409,66	1,3	MRN 32	5550	32,8	13,8	75,00	1,7952
28,0	28,28	49,5	407,92	2,2	MRN 42	8920	54,3	35,3	75,00	6,1008		
		27,55	50,8	395,05	> 3,0	MRN 52	8090	84,2	65,2	75,00	20,3546	
		27,69	50,6	399,67	> 3,0	MRN 62	6000	133,8	114,8	75,00	34,0539	
		31,5	30	46,7	434,05	1,7	MRN 42	9290	54,3	35,3	75,00	6,2602
31,5	30,02	46,6	431,85	> 3,0	MRN 52	9610	84,2	65,2	75,00	20,1029		
		30,38	46,1	437,88	> 3,0	MRN 62	7160	133,8	114,8	75,00	33,2259	
		35,5	37,39	37,4	542,67	1,4	MRN 42	10030	54,3	35,3	75,00	6,0256
35,5	36,31	38,6	520,00	2,5	MRN 52	13530	84,2	65,2	75,00	19,6654		
		37,35	37,5	537,18	> 3,0	MRN 62	16090	133,8	114,8	75,00	31,7360	
40,0	38,12	36,7	550,00	1,2	MRN 42	10140	54,3	35,3	75,00	5,8382		

## Getriebe - Gearboxes - Riduttori RN

1400 rpm

Selezione Motoriduttore - Geared Motor Selection - Getriebemotorauswahl

P <sub>1</sub> [kW]	i <sub>n</sub>	i <sub>r</sub>	N <sub>2</sub> [rpm]	M <sub>2</sub> [Nm]	FS	Tipo - Size - Größe	F <sub>r2</sub> [N]	MRN [kg]	FRN [kg]	J <sub>m</sub> × 10 <sup>-4</sup>	J <sub>1</sub> × 10 <sup>-4</sup>
2,2	40,0	34,07	41,1	486,67	1,5	MRN 43	9670	56,5	37,5	75,00	4,3102
		40,79	34,3	585,11	2,1	MRN 52	14620	84,2	65,2	75,00	19,9025
		37,28	37,6	526,09	> 3,0	MRN 53	9220	88,8	69,8	75,00	13,8553
		39,49	35,5	571,12	> 3,0	MRN 62	18170	133,8	114,8	75,00	33,3872
		38,2	36,7	537,59	> 3,0	MRN 63	7350	140,0	121,0	75,00	22,6869
	45,0	45,27	30,9	660,00	1,1	MRN 42	10720	54,3	35,3	75,00	5,8675
		42,59	32,9	606,67	1,5	MRN 43	10030	56,5	37,5	75,00	4,2058
		45,38	30,8	654,05	1,7	MRN 52	15630	84,2	65,2	75,00	19,2544
		47,28	29,6	671,79	2,5	MRN 53	8610	88,8	69,8	75,00	13,7108
		43,31	32,3	625,54	> 3,0	MRN 62	18380	133,8	114,8	75,00	32,6717
	50,0	50,4	27,8	717,39	1,0	MRN 42	11110	54,3	35,3	75,00	5,7968
		49,33	28,4	715,00	1,8	MRN 52	15030	84,2	65,2	75,00	19,5092
		53,26	26,3	770,00	> 3,0	MRN 62	18970	133,8	114,8	75,00	31,3694
		48,44	28,9	686,24	> 3,0	MRN 63	7670	140,0	121,0	75,00	22,2684
	56,0	54,21	25,8	770,00	1,3	MRN 43	9830	56,5	37,5	75,00	4,1359
		57,27	24,4	802,08	2,2	MRN 53	8800	88,8	69,8	75,00	13,6244
		59,89	23,4	865,57	2,8	MRN 62	19310	133,8	114,8	75,00	30,7868
		58,68	23,9	831,11	> 3,0	MRN 63	7800	140,0	121,0	75,00	22,0179
	63,0	66,13	21,2	946,96	1,0	MRN 43	10110	56,5	37,5	75,00	4,0833
		61,67	22,7	893,75	1,5	MRN 52	15530	84,2	65,2	75,00	19,1667
71,0	70,6	19,8	987,18	1,8	MRN 53	9010	88,8	69,8	75,00	13,5519	
	72,33	19,4	1024,66	> 3,0	MRN 63	7800	140,0	121,0	75,00	21,8075	
80,0	79,72	17,6	1118,86	1,6	MRN 63	25090	140,0	121,0	75,00	19,9592	
90,0	89,26	15,7	1256,13	1,4	MRN 53	8500	88,8	69,8	75,00	13,4907	
	91,45	15,3	1289,66	2,6	MRN 63	7800	140,0	121,0	75,00	21,6298	
100,0	105,42	13,3	1477,14	1,6	MRN 63	22430	140,0	121,0	75,00	19,8591	
112,0	117,24	11,9	1640,83	1,1	MRN 53	7200	88,8	69,8	75,00	13,4396	
125,0	120,13	11,7	1700,00	2,0	MRN 63	7800	140,0	121,0	75,00	21,4811	
140,0	143,08	9,78	2021,62	1,7	MRN 63	7800	140,0	121,0	75,00	21,4145	
160,0	156,94	8,92	2200,00	1,5	MRN 63	7900	140,0	121,0	75,00	21,3834	
200,0	192,98	7,25	2700,00	1,0	MRN 63	21200	140,0	121,0	75,00	21,3276	
3	6,3	5,76	243	111,76	1,7	MRN 22	3200	30,4	9,4	85,00	2,5855
		5,59	250	110,09	> 3,0	MRN 32	4760	34,8	13,8	85,00	4,8684
		5,74	244	112,71	> 3,0	MRN 42	5030	56,3	35,3	85,00	13,0943
		5,64	248	110,74	> 3,0	MRN 52	7550	86,2	65,2	85,00	37,6347
		5,77	250	109,82	> 3,0	MRN 62	10060	135,8	114,8	85,00	84,0612
	7,1	7,37	190	140,22	1,5	MRN 22	3450	30,4	9,4	85,00	2,1881
		7,17	195	140,22	> 3,0	MRN 32	5180	34,8	13,8	85,00	3,8232
		7,26	193	142,77	> 3,0	MRN 42	5190	56,3	35,3	85,00	10,7969
		7,46	188	146,51	> 3,0	MRN 52	8250	86,2	65,2	85,00	31,2885
		7,39	189	145,25	> 3,0	MRN 62	9540	135,8	114,8	85,00	68,0211
	8,0	7,8	179	150,00	1,5	MRN 22	3530	30,4	9,4	85,00	2,2972
		7,9	177	156,34	2,4	MRN 32	5410	34,8	13,8	85,00	3,9288
		7,59	185	148,92	> 3,0	MRN 42	5680	56,3	35,3	85,00	11,2674
		7,66	183	150,66	> 3,0	MRN 52	8410	86,2	65,2	85,00	31,9539
		7,97	176	156,77	> 3,0	MRN 62	11380	135,8	114,8	85,00	68,6806
	9,0	9,07	154	175,61	1,4	MRN 22	3690	30,4	9,4	85,00	1,9599
		8,84	158	173,49	2,8	MRN 32	5180	34,8	13,8	85,00	3,2176
		9,08	154	178,00	> 3,0	MRN 42	5660	56,3	35,3	85,00	9,2579
		9,46	148	185,84	> 3,0	MRN 52	8900	86,2	65,2	85,00	27,6749



## RN Riduttori - Gearboxes - Getriebe

Selezione Motoriduttore - Geared Motor Selection - Getriebemotorauswahl

1400 rpm

P <sub>1</sub> [kW]	i <sub>n</sub>	i <sub>r</sub>	N <sub>2</sub> [rpm]	M <sub>2</sub> [Nm]	FS	Tipo - Size - Größe	F <sub>r2</sub> [N]	MRN [kg]	FRN [kg]	J <sub>m</sub> × 10 <sup>-4</sup>	J <sub>1</sub> × 10 <sup>-4</sup>
3	9,0	9,38	149	184,32	> 3,0	MRN 62	9030	135,8	114,8	85,00	56,8499
	10,0	9,98	140	191,67	1,2	MRN 22	3850	30,4	9,4	85,00	2,0120
		10,13	138	200,00	1,9	MRN 32	5890	34,8	13,8	85,00	3,2515
		9,6	146	188,18	> 3,0	MRN 42	6200	56,3	35,3	85,00	9,6555
		10,13	138	199,42	> 3,0	MRN 52	9280	86,2	65,2	85,00	28,0395
		10,54	133	206,90	> 3,0	MRN 62	12550	135,8	114,8	85,00	58,6662
11,2	11,33	124	216,67	1,2	MRN 22	3890	30,4	9,4	85,00	1,7848	
	11,06	127	217,81	2,4	MRN 32	4550	34,8	13,8	85,00	2,7466	
	11,55	121	227,50	> 3,0	MRN 42	6170	56,3	35,3	85,00	8,0995	
	11,45	122	224,64	> 3,0	MRN 52	8400	86,2	65,2	85,00	25,5151	
	11,36	123	223,02	> 3,0	MRN 62	5620	135,8	114,8	85,00	50,1639	
12,5	12,29	114	237,93	1,0	MRN 22	4140	30,4	9,4	85,00	1,8436	
	12,49	112	247,83	1,5	MRN 32	6330	34,8	13,8	85,00	2,8412	
	12	117	235,96	3,0	MRN 42	6720	56,3	35,3	85,00	8,5274	
	12,85	109	252,52	> 3,0	MRN 52	10080	86,2	65,2	85,00	25,6545	
14,0	14,51	96,5	281,25	1,1	MRN 22	3720	30,4	9,4	85,00	1,6479	
	14,18	98,8	279,31	1,9	MRN 32	4700	34,8	13,8	85,00	2,3720	
	14,09	99,3	276,00	> 3,0	MRN 42	6810	56,3	35,3	85,00	7,4107	
	14,12	99,2	277,59	> 3,0	MRN 52	8470	86,2	65,2	85,00	23,7029	
	14	100	274,78	> 3,0	MRN 62	5450	135,8	114,8	85,00	44,5468	
16,0	15,36	91,2	300,00	0,8	MRN 22	4480	30,4	9,4	85,00	1,7103	
	15,63	89,6	307,89	1,3	MRN 32	6830	34,8	13,8	85,00	2,5063	
	15,27	91,7	300,00	2,4	MRN 42	7330	56,3	35,3	85,00	7,6485	
	15,56	90	305,17	> 3,0	MRN 52	10780	86,2	65,2	85,00	24,1384	
	16,19	86,4	318,40	> 3,0	MRN 62	11630	135,8	114,8	85,00	46,1997	
18,0	17,87	78,4	344,44	0,9	MRN 22	3590	30,4	9,4	85,00	1,5647	
	18,84	74,3	366,67	1,5	MRN 32	4860	34,8	13,8	85,00	2,0717	
	17,59	79,6	344,44	2,7	MRN 42	7410	56,3	35,3	85,00	6,8426	
	17,85	78,4	351,80	> 3,0	MRN 52	8680	86,2	65,2	85,00	22,1741	
	17,7	79,1	347,83	> 3,0	MRN 62	3100	135,8	114,8	85,00	39,8027	
20,0	20,03	69,9	390,00	1,0	MRN 32	7400	34,8	13,8	85,00	2,2256	
	19,19	73	375,79	> 3,0	MRN 52	11580	86,2	65,2	85,00	22,7969	
	19,96	70,1	391,38	> 3,0	MRN 62	15790	135,8	114,8	85,00	41,9382	
22,4	22,18	63,1	434,21	1,3	MRN 32	5000	34,8	13,8	85,00	1,9456	
	22,69	61,7	447,62	2,1	MRN 42	8160	56,3	35,3	85,00	6,4129	
	23,45	59,7	462,62	> 3,0	MRN 52	8020	86,2	65,2	85,00	20,8963	
	23,25	60,2	457,75	> 3,0	MRN 62	8000	135,8	114,8	85,00	35,8331	
25,0	26,62	52,6	521,74	0,8	MRN 32	7750	34,8	13,8	85,00	1,9888	
	24,26	57,7	473,68	2,5	MRN 52	12560	86,2	65,2	85,00	21,6073	
	25,24	55,5	494,51	> 3,0	MRN 62	16780	135,8	114,8	85,00	38,1707	
28,0	28,93	48,4	558,62	1,0	MRN 32	5550	34,8	13,8	85,00	1,7952	
	28,28	49,5	556,25	1,6	MRN 42	8920	56,3	35,3	85,00	6,1008	
	27,55	50,8	538,71	> 3,0	MRN 52	8090	86,2	65,2	85,00	20,3546	
	27,69	50,6	545,00	> 3,0	MRN 62	6000	135,8	114,8	85,00	34,0539	
31,5	30	46,7	591,89	1,2	MRN 42	9290	56,3	35,3	85,00	6,2602	
	30,02	46,6	588,89	2,7	MRN 52	9610	86,2	65,2	85,00	20,1029	
	30,38	46,1	597,12	> 3,0	MRN 62	7160	135,8	114,8	85,00	33,2259	
35,5	37,39	37,4	740,00	1,0	MRN 42	10030	56,3	35,3	85,00	6,0256	
	36,31	38,6	709,09	1,8	MRN 52	13530	86,2	65,2	85,00	19,6654	
	37,35	37,5	732,52	> 3,0	MRN 62	16090	135,8	114,8	85,00	31,7360	

## Getriebe - Gearboxes - Riduttori RN

1400 rpm

Selezione Motoriduttore - Geared Motor Selection - Getriebemotorauswahl

P <sub>1</sub> [kW]	i <sub>n</sub>	i <sub>r</sub>	N <sub>2</sub> [rpm]	M <sub>2</sub> [Nm]	FS	Tipo - Size - Größe	F <sub>r2</sub> [N]	MRN [kg]	FRN [kg]	J <sub>m</sub> × 10 <sup>-4</sup>	J <sub>1</sub> × 10 <sup>-4</sup>	
3	40,0	38,12	36,7	750,00	0,9	MRN 42	10140	56,3	35,3	85,00	5,8382	
		34,07	41,1	663,64	1,1	MRN 43	9670	58,5	37,5	85,00	4,3102	
		40,79	34,3	797,87	1,6	MRN 52	14620	86,2	65,2	85,00	19,9025	
		37,28	37,6	717,39	2,3	MRN 53	9220	90,8	69,8	85,00	13,8553	
		39,49	35,5	778,80	> 3,0	MRN 62	18170	135,8	114,8	85,00	33,3872	
		38,2	36,7	733,08	> 3,0	MRN 63	7350	142,0	121,0	85,00	22,6869	
	45,0	45,27	30,9	900,00	0,8	MRN 42	10720	56,3	35,3	85,00	5,8675	
		42,59	32,9	827,27	1,1	MRN 43	10030	58,5	37,5	85,00	4,2058	
		45,38	30,8	891,89	1,2	MRN 52	15630	86,2	65,2	85,00	19,2544	
		47,28	29,6	916,07	1,9	MRN 53	8610	90,8	69,8	85,00	13,7108	
		43,31	32,3	853,01	2,8	MRN 62	18380	135,8	114,8	85,00	32,6717	
		50,0	50,4	27,8	978,26	0,8	MRN 42	11110	56,3	35,3	85,00	5,7968
	50,0	49,33	28,4	975,00	1,3	MRN 52	15030	86,2	65,2	85,00	19,5092	
		53,26	26,3	1050,00	2,3	MRN 62	18970	135,8	114,8	85,00	31,3694	
		48,44	28,9	935,78	> 3,0	MRN 63	7670	142,0	121,0	85,00	22,2684	
		56,0	54,21	25,8	1050,00	0,9	MRN 43	9830	58,5	37,5	85,00	4,1359
		57,27	24,4	1093,75	1,6	MRN 53	8800	90,8	69,8	85,00	13,6244	
		59,89	23,4	1180,33	2,0	MRN 62	19310	135,8	114,8	85,00	30,7868	
	58,68	63,0	23,9	1133,33	3,0	MRN 63	7800	142,0	121,0	85,00	22,0179	
			66,13	21,2	1291,30	0,8	MRN 43	10110	58,5	37,5	85,00	4,0833
			61,67	22,7	1218,75	1,1	MRN 52	15530	86,2	65,2	85,00	19,1667
	71,0	70,6	19,8	1346,15	1,3	MRN 53	9010	90,8	69,8	85,00	13,5519	
		72,33	19,4	1397,26	2,4	MRN 63	7800	142,0	121,0	85,00	21,8075	
	80,0	79,72	17,6	1525,71	1,2	MRN 63	25090	142,0	121,0	85,00	19,9592	
	90,0	89,26	15,7	1712,90	1,0	MRN 53	8500	90,8	69,8	85,00	13,4907	
		91,45	15,3	1758,62	1,9	MRN 63	7800	142,0	121,0	85,00	21,6298	
	100,0	105,42	13,3	2014,29	1,2	MRN 63	22430	142,0	121,0	85,00	19,8591	
	112,0	117,24	11,9	2237,50	0,8	MRN 53	7200	90,8	69,8	85,00	13,4396	
	125,0	120,13	11,7	2318,18	1,5	MRN 63	7800	142,0	121,0	85,00	21,4811	
	140,0	143,08	9,78	2756,76	1,2	MRN 63	7800	142,0	121,0	85,00	21,4145	
160,0	156,94	8,92	3000,00	1,1	MRN 63	7900	142,0	121,0	85,00	21,3834		
200,0	192,98	7,25	3681,82	0,7	MRN 63	21200	142,0	121,0	85,00	21,3276		
4	6,3	5,76	243	149,02	1,3	MRN 22	3200	38,4	9,4	130,00	2,5855	
		5,59	250	146,79	2,7	MRN 32	4760	42,8	13,8	130,00	4,8684	
		5,74	244	150,28	> 3,0	MRN 42	5030	64,3	35,3	130,00	13,0943	
		5,64	248	147,65	> 3,0	MRN 52	7550	94,2	65,2	130,00	37,6347	
		5,77	250	146,42	> 3,0	MRN 62	10060	143,8	114,8	130,00	84,0612	
	7,1	7,37	190	186,96	1,2	MRN 22	3450	38,4	9,4	130,00	2,1881	
		7,17	195	186,96	2,3	MRN 32	5180	42,8	13,8	130,00	3,8232	
		7,26	193	190,36	> 3,0	MRN 42	5190	64,3	35,3	130,00	10,7969	
		7,46	188	195,35	> 3,0	MRN 52	8250	94,2	65,2	130,00	31,2885	
		7,39	189	193,67	> 3,0	MRN 62	9540	143,8	114,8	130,00	68,0211	
	8,0	7,8	179	200,00	1,1	MRN 22	3530	38,4	9,4	130,00	2,2972	
		7,9	177	208,45	1,8	MRN 32	5410	42,8	13,8	130,00	3,9288	
		7,59	185	198,56	> 3,0	MRN 42	5680	64,3	35,3	130,00	11,2674	
		7,66	183	200,88	> 3,0	MRN 52	8410	94,2	65,2	130,00	31,9539	
		7,97	176	209,03	> 3,0	MRN 62	11380	143,8	114,8	130,00	68,6806	
	9,0	9,07	154	234,15	1,0	MRN 22	3690	38,4	9,4	130,00	1,9599	
		8,84	158	231,33	2,1	MRN 32	5180	42,8	13,8	130,00	3,2176	
		9,08	154	237,33	> 3,0	MRN 42	5660	64,3	35,3	130,00	9,2579	

## RN Riduttori - Gearboxes - Getriebe

Selezione Motoriduttore - Geared Motor Selection - Getriebemotorauswahl

1400 rpm

P <sub>1</sub> [kW]	i <sub>n</sub>	i <sub>r</sub>	N <sub>2</sub> [rpm]	M <sub>2</sub> [Nm]	FS	Tipo - Size - Größe	F <sub>r2</sub> [N]	MRN [kg]	FRN [kg]	J <sub>m</sub> × 10 <sup>-4</sup>	J <sub>1</sub> × 10 <sup>-4</sup>
4	9,0	9,46	148	247,79	> 3,0	MRN 52	8900	94,2	65,2	130,00	27,6749
		9,38	149	245,76	> 3,0	MRN 62	9030	143,8	114,8	130,00	56,8499
10,0	10,13	10,13	138	266,67	1,4	MRN 32	5890	42,8	13,8	130,00	3,2515
		9,6	146	250,91	2,8	MRN 42	6200	64,3	35,3	130,00	9,6555
		10,13	138	265,90	> 3,0	MRN 52	9280	94,2	65,2	130,00	28,0395
		10,54	133	275,86	> 3,0	MRN 62	12550	143,8	114,8	130,00	58,6662
11,2	11,06	11,06	127	290,41	1,8	MRN 32	4550	42,8	13,8	130,00	2,7466
		11,55	121	303,33	3,0	MRN 42	6170	64,3	35,3	130,00	8,0995
		11,45	122	299,52	> 3,0	MRN 52	8400	94,2	65,2	130,00	25,5151
		11,36	123	297,36	> 3,0	MRN 62	5620	143,8	114,8	130,00	50,1639
12,5	12,49	12,49	112	330,43	1,2	MRN 32	6330	42,8	13,8	130,00	2,8412
		12	117	314,61	2,2	MRN 42	6720	64,3	35,3	130,00	8,5274
		12,85	109	336,69	> 3,0	MRN 52	10080	94,2	65,2	130,00	25,6545
14,0	14,18	14,18	98,8	372,41	1,5	MRN 32	4700	42,8	13,8	130,00	2,3720
		14,09	99,3	368,00	2,5	MRN 42	6810	64,3	35,3	130,00	7,4107
		14,12	99,2	370,11	> 3,0	MRN 52	8470	94,2	65,2	130,00	23,7029
		14	100	366,38	> 3,0	MRN 62	5450	143,8	114,8	130,00	44,5468
16,0	15,27	15,27	91,7	400,00	1,8	MRN 42	7330	64,3	35,3	130,00	7,6485
		15,56	90	406,90	2,9	MRN 52	10780	94,2	65,2	130,00	24,1384
		16,19	86,4	424,53	> 3,0	MRN 62	11630	143,8	114,8	130,00	46,1997
18,0	17,59	17,59	79,6	459,26	2,0	MRN 42	7410	64,3	35,3	130,00	6,8426
		17,85	78,4	469,06	> 3,0	MRN 52	8680	94,2	65,2	130,00	22,1741
		17,7	79,1	463,77	> 3,0	MRN 62	3100	143,8	114,8	130,00	39,8027
20,0	19,19	19,19	73	501,05	2,4	MRN 52	11580	94,2	65,2	130,00	22,7969
		19,96	70,1	521,84	> 3,0	MRN 62	15790	143,8	114,8	130,00	41,9382
22,4	22,69	22,69	61,7	596,83	1,6	MRN 42	8160	64,3	35,3	130,00	6,4129
		23,45	59,7	616,82	2,7	MRN 52	8020	94,2	65,2	130,00	20,8963
		23,25	60,2	610,33	> 3,0	MRN 62	8000	143,8	114,8	130,00	35,8331
25,0	24,26	24,26	57,7	631,58	1,9	MRN 52	12560	94,2	65,2	130,00	21,6073
		25,24	55,5	659,34	> 3,0	MRN 62	16780	143,8	114,8	130,00	38,1707
28,0	28,28	28,28	49,5	741,67	1,2	MRN 42	8920	64,3	35,3	130,00	6,1008
		27,55	50,8	718,28	2,3	MRN 52	8090	94,2	65,2	130,00	20,3546
		27,69	50,6	726,67	> 3,0	MRN 62	6000	143,8	114,8	130,00	34,0539
31,5	30,02	30,02	46,6	785,19	2,0	MRN 52	9610	94,2	65,2	130,00	20,1029
		30,38	46,1	796,15	> 3,0	MRN 62	7160	143,8	114,8	130,00	33,2259
35,5	36,31	36,31	38,6	945,45	1,4	MRN 52	13530	94,2	65,2	130,00	19,6654
		37,35	37,5	976,70	2,6	MRN 62	16090	143,8	114,8	130,00	31,7360
40,0	40,79	40,79	34,3	1063,83	1,2	MRN 52	14620	94,2	65,2	130,00	19,9025
		37,28	37,6	956,52	1,7	MRN 53	9220	98,8	69,8	130,00	13,8553
		39,49	35,5	1038,40	> 3,0	MRN 62	18170	143,8	114,8	130,00	33,3872
		38,2	36,7	977,44	> 3,0	MRN 63	7350	150,0	121,0	130,00	22,6869
45,0	45,38	45,38	30,8	1189,19	0,9	MRN 52	15630	94,2	65,2	130,00	19,2544
		47,28	29,6	1221,43	1,4	MRN 53	8610	98,8	69,8	130,00	13,7108
50,0	43,31	43,31	32,3	1137,35	2,1	MRN 62	18380	143,8	114,8	130,00	32,6717
		49,33	28,4	1300,00	1,0	MRN 52	15030	94,2	65,2	130,00	19,5092
		53,26	26,3	1400,00	1,7	MRN 62	18970	143,8	114,8	130,00	31,3694
56,0	48,44	48,44	28,9	1247,71	2,7	MRN 63	7670	150,0	121,0	130,00	22,2684
		57,27	24,4	1458,33	1,2	MRN 53	8800	98,8	69,8	130,00	13,6244
		59,89	23,4	1573,77	1,5	MRN 62	19310	143,8	114,8	130,00	30,7868
		58,68	23,9	1511,11	2,3	MRN 63	7800	150,0	121,0	130,00	22,0179

## Getriebe - Gearboxes - Riduttori RN

Selezione Motoriduttore - Geared Motor Selection - Getriebemotorauswahl

1400 rpm

P <sub>1</sub> [kW]	i <sub>n</sub>	i <sub>r</sub>	N <sub>2</sub> [rpm]	M <sub>2</sub> [Nm]	FS	Tipo - Size - Größe	F <sub>r2</sub> [N]	MRN [kg]	FRN [kg]	J <sub>m</sub> × 10 <sup>-4</sup>	J <sub>1</sub> × 10 <sup>-4</sup>
4	63,0	61,67	22,7	1625,00	0,8	MRN 52	15530	94,2	65,2	130,00	19,1667
	71,0	70,6	19,8	1794,87	1,0	MRN 53	9010	98,8	69,8	130,00	13,5519
		72,33	19,4	1863,01	1,8	MRN 63	7800	150,0	121,0	130,00	21,8075
	80,0	79,72	17,6	2034,29	0,9	MRN 63	25090	150,0	121,0	130,00	19,9592
	90,0	89,26	15,7	2283,87	0,8	MRN 53	8500	98,8	69,8	130,00	13,4907
		91,45	15,3	2344,83	1,5	MRN 63	7800	150,0	121,0	130,00	21,6298
	100,0	105,42	13,3	2685,71	0,9	MRN 63	22430	150,0	121,0	130,00	19,8591
	125,0	120,13	11,7	3090,91	1,1	MRN 63	7800	150,0	121,0	130,00	21,4811
	140,0	143,08	9,78	3675,68	0,9	MRN 63	7800	150,0	121,0	130,00	21,4145
160,0	156,94	8,92	4000,00	0,8	MRN 63	7900	150,0	121,0	130,00	21,3834	
5,5	6,3	5,64	248	203,02	> 3,0	MRN 52	7550	108,2	65,2	240,00	37,6347
		5,77	250	201,33	> 3,0	MRN 62	10060	157,8	114,8	240,00	84,0612
	7,1	7,46	188	268,60	> 3,0	MRN 52	8250	108,2	65,2	240,00	31,2885
		7,39	189	266,29	> 3,0	MRN 62	9540	157,8	114,8	240,00	68,0211
	8,0	7,66	183	276,21	> 3,0	MRN 52	8410	108,2	65,2	240,00	31,9539
		7,97	176	287,41	> 3,0	MRN 62	11380	157,8	114,8	240,00	68,6806
	9,0	9,46	148	340,71	> 3,0	MRN 52	8900	108,2	65,2	240,00	27,6749
		9,38	149	337,92	> 3,0	MRN 62	9030	157,8	114,8	240,00	56,8499
	10,0	10,13	138	365,61	> 3,0	MRN 52	9280	108,2	65,2	240,00	28,0395
		10,54	133	379,31	> 3,0	MRN 62	12550	157,8	114,8	240,00	58,6662
	11,2	11,45	122	411,84	> 3,0	MRN 52	8400	108,2	65,2	240,00	25,5151
		11,36	123	408,87	> 3,0	MRN 62	5620	157,8	114,8	240,00	50,1639
	12,5	12,85	109	462,95	2,5	MRN 52	10080	108,2	65,2	240,00	25,6545
		14,0	14,12	99,2	508,91	> 3,0	MRN 52	8470	108,2	65,2	240,00
			14	100	503,77	> 3,0	MRN 62	5450	157,8	114,8	240,00
	16,0	15,56	90	559,48	2,1	MRN 52	10780	108,2	65,2	240,00	24,1384
		16,19	86,4	583,73	> 3,0	MRN 62	11630	157,8	114,8	240,00	46,1997
	18,0	17,85	78,4	644,96	2,5	MRN 52	8680	108,2	65,2	240,00	22,1741
		17,7	79,1	637,68	> 3,0	MRN 62	3100	157,8	114,8	240,00	39,8027
	20,0	19,19	73	688,95	1,7	MRN 52	11580	108,2	65,2	240,00	22,7969
		19,96	70,1	717,53	> 3,0	MRN 62	15790	157,8	114,8	240,00	41,9382
	22,4	23,45	59,7	848,13	1,9	MRN 52	8020	108,2	65,2	240,00	20,8963
		23,25	60,2	839,20	> 3,0	MRN 62	8000	157,8	114,8	240,00	35,8331
	25,0	24,26	57,7	868,42	1,4	MRN 52	12560	108,2	65,2	240,00	21,6073
		25,24	55,5	906,59	> 3,0	MRN 62	16780	157,8	114,8	240,00	38,1707
	28,0	27,55	50,8	987,63	1,7	MRN 52	8090	108,2	65,2	240,00	20,3546
		27,69	50,6	999,17	> 3,0	MRN 62	6000	157,8	114,8	240,00	34,0539
	31,5	30,02	46,6	1079,63	1,5	MRN 52	9610	108,2	65,2	240,00	20,1029
		30,38	46,1	1094,71	2,8	MRN 62	7160	157,8	114,8	240,00	33,2259
	35,5	36,31	38,6	1300,00	1,0	MRN 52	13530	108,2	65,2	240,00	19,6654
		37,35	37,5	1342,96	1,9	MRN 62	16090	157,8	114,8	240,00	31,7360
	40,0	37,28	37,6	1315,22	1,3	MRN 53	9220	112,8	69,8	240,00	13,8553
		39,49	35,5	1427,80	2,3	MRN 62	18170	157,8	114,8	240,00	33,3872
45,0	38,2	36,7	1343,98	2,4	MRN 63	7350	164,0	121,0	240,00	22,6869	
	47,28	29,6	1679,46	1,0	MRN 53	8610	112,8	69,8	240,00	13,7108	
50,0	43,31	32,3	1563,86	1,5	MRN 62	18380	157,8	114,8	240,00	32,6717	
	53,26	26,3	1925,00	1,2	MRN 62	18970	157,8	114,8	240,00	31,3694	
56,0	48,44	28,9	1715,60	2,0	MRN 63	7670	164,0	121,0	240,00	22,2684	
	59,89	23,4	2163,93	1,1	MRN 62	19310	157,8	114,8	240,00	30,7868	
	58,68	23,9	2077,78	1,6	MRN 63	7800	164,0	121,0	240,00	22,0179	

## RN Riduttori - Gearboxes - Getriebe

Selezione Motoriduttore - Geared Motor Selection - Getriebemotorauswahl

1400 rpm

P <sub>1</sub> [kW]	i <sub>n</sub>	i <sub>r</sub>	N <sub>2</sub> [rpm]	M <sub>2</sub> [Nm]	FS	Tipo - Size - Größe	F <sub>r2</sub> [N]	MRN [kg]	FRN [kg]	J <sub>m</sub> × 10 <sup>-4</sup>	J <sub>1</sub> × 10 <sup>-4</sup>
5,5	71,0	72,33	19,4	2561,64	1,3	MRN 63	7800	164,0	121,0	240,00	21,8075
	90,0	91,45	15,3	3224,14	1,1	MRN 63	7800	164,0	121,0	240,00	21,6298
7,5	6,3	5,64	248	276,85	> 3,0	MRN 52	7550	117,2	65,2	330,00	37,6347
		5,77	250	274,54	> 3,0	MRN 62	10060	166,8	114,8	330,00	84,0612
	7,1	7,46	188	366,28	> 3,0	MRN 52	8250	117,2	65,2	330,00	31,2885
		7,39	189	363,13	> 3,0	MRN 62	9540	166,8	114,8	330,00	68,0211
	8,0	7,66	183	376,65	3,0	MRN 52	8410	117,2	65,2	330,00	31,9539
		7,97	176	391,92	> 3,0	MRN 62	11380	166,8	114,8	330,00	68,6806
	9,0	9,46	148	464,60	3,0	MRN 52	8900	117,2	65,2	330,00	27,6749
		9,38	149	460,81	> 3,0	MRN 62	9030	166,8	114,8	330,00	56,8499
	10,0	10,13	138	498,55	2,3	MRN 52	9280	117,2	65,2	330,00	28,0395
		10,54	133	517,24	> 3,0	MRN 62	12550	166,8	114,8	330,00	58,6662
	11,2	11,45	122	561,59	2,8	MRN 52	8400	117,2	65,2	330,00	25,5151
		11,36	123	557,55	> 3,0	MRN 62	5620	166,8	114,8	330,00	50,1639
	12,5	12,85	109	631,29	1,9	MRN 52	10080	117,2	65,2	330,00	25,6545
	14,0	14,12	99,2	693,97	2,3	MRN 52	8470	117,2	65,2	330,00	23,7029
		14	100	686,96	> 3,0	MRN 62	5450	166,8	114,8	330,00	44,5468
	16,0	15,56	90	762,93	1,5	MRN 52	10780	117,2	65,2	330,00	24,1384
		16,19	86,4	795,99	2,8	MRN 62	11630	166,8	114,8	330,00	46,1997
	18,0	17,85	78,4	879,50	1,9	MRN 52	8680	117,2	65,2	330,00	22,1741
		17,7	79,1	869,57	> 3,0	MRN 62	3100	166,8	114,8	330,00	39,8027
	20,0	19,19	73	939,47	1,3	MRN 52	11580	117,2	65,2	330,00	22,7969
		19,96	70,1	978,45	2,3	MRN 62	15790	166,8	114,8	330,00	41,9382
	22,4	23,45	59,7	1156,54	1,4	MRN 52	8020	117,2	65,2	330,00	20,8963
		23,25	60,2	1144,37	2,8	MRN 62	8000	166,8	114,8	330,00	35,8331
	25,0	24,26	57,7	1184,21	1,0	MRN 52	12560	117,2	65,2	330,00	21,6073
		25,24	55,5	1236,26	2,4	MRN 62	16780	166,8	114,8	330,00	38,1707
	28,0	27,55	50,8	1346,77	1,2	MRN 52	8090	117,2	65,2	330,00	20,3546
		27,69	50,6	1362,50	2,4	MRN 62	6000	166,8	114,8	330,00	34,0539
	31,5	30,02	46,6	1472,22	1,1	MRN 52	9610	117,2	65,2	330,00	20,1029
		30,38	46,1	1492,79	2,1	MRN 62	7160	166,8	114,8	330,00	33,2259
	35,5	36,31	38,6	1772,73	0,7	MRN 52	13530	117,2	65,2	330,00	19,6654
		37,35	37,5	1831,31	1,4	MRN 62	16090	166,8	114,8	330,00	31,7360
	40,0	37,28	37,6	1793,48	0,9	MRN 53	9220	121,8	69,8	330,00	13,8553
		39,49	35,5	1947,00	1,7	MRN 62	18170	166,8	114,8	330,00	33,3872
		38,2	36,7	1832,71	1,8	MRN 63	7350	173,0	121,0	330,00	22,6869
	45,0	47,28	29,6	2290,18	0,7	MRN 53	8610	121,8	69,8	330,00	13,7108
		43,31	32,3	2132,53	1,1	MRN 62	18380	166,8	114,8	330,00	32,6717
	50,0	53,26	26,3	2625,00	0,9	MRN 62	18970	166,8	114,8	330,00	31,3694
		48,44	28,9	2339,45	1,5	MRN 63	7670	173,0	121,0	330,00	22,2684
	56,0	59,89	23,4	2950,82	0,8	MRN 62	19310	166,8	114,8	330,00	30,7868
		58,68	23,9	2833,33	1,2	MRN 63	7800	173,0	121,0	330,00	22,0179
	71,0	72,33	19,4	3493,15	1,0	MRN 63	7800	173,0	121,0	330,00	21,8075
	90,0	91,45	15,3	4396,55	0,8	MRN 63	7800	173,0	121,0	330,00	21,6298
11	6,3	5,64	248	406,04	2,7	MRN 52	7550	155,2	65,2	620,00	37,6347
		5,77	250	402,66	> 3,0	MRN 62	10060	204,8	114,8	620,00	84,0612
	7,1	7,46	188	537,21	2,3	MRN 52	8250	155,2	65,2	620,00	31,2885
		7,39	189	532,59	> 3,0	MRN 62	9540	204,8	114,8	620,00	68,0211
	8,0	7,66	183	552,42	2,1	MRN 52	8410	155,2	65,2	620,00	31,9539
		7,97	176	574,82	> 3,0	MRN 62	11380	204,8	114,8	620,00	68,6806

## Getriebe - Gearboxes - Riduttori RN

1400 rpm

Selezione Motoriduttore - Geared Motor Selection - Getriebemotorauswahl

P <sub>1</sub> [kW]	i <sub>n</sub>	i <sub>r</sub>	N <sub>2</sub> [rpm]	M <sub>2</sub> [Nm]	FS	Tipo - Size - Größe	F <sub>r2</sub> [N]	MRN [kg]	FRN [kg]	J <sub>m</sub> × 10 <sup>-4</sup>	J <sub>1</sub> × 10 <sup>-4</sup>
11	9,0	9,46	148	681,42	2,1	MRN 52	8900	155,2	65,2	620,00	27,6749
		9,38	149	675,85	> 3,0	MRN 62	9030	204,8	114,8	620,00	56,8499
	10,0	10,13	138	731,21	1,6	MRN 52	9280	155,2	65,2	620,00	28,0395
		10,54	133	758,62	2,9	MRN 62	12550	204,8	114,8	620,00	58,6662
	11,2	11,45	122	823,67	1,9	MRN 52	8400	155,2	65,2	620,00	25,5151
		11,36	123	817,75	> 3,0	MRN 62	5620	204,8	114,8	620,00	50,1639
	12,5	12,85	109	925,90	1,3	MRN 52	10080	155,2	65,2	620,00	25,6545
	14,0	14,12	99,2	1017,82	1,6	MRN 52	8470	155,2	65,2	620,00	23,7029
		14	100	1007,54	> 3,0	MRN 62	5450	204,8	114,8	620,00	44,5468
	16,0	15,56	90	1118,97	1,1	MRN 52	10780	155,2	65,2	620,00	24,1384
		16,19	86,4	1167,45	1,9	MRN 62	11630	204,8	114,8	620,00	46,1997
	18,0	17,85	78,4	1289,93	1,3	MRN 52	8680	155,2	65,2	620,00	22,1741
		17,7	79,1	1275,36	2,5	MRN 62	3100	204,8	114,8	620,00	39,8027
	20,0	19,96	70,1	1435,06	1,6	MRN 62	15790	204,8	114,8	620,00	41,9382
	22,4	23,25	60,2	1678,40	1,9	MRN 62	8000	204,8	114,8	620,00	35,8331
	25,0	25,24	55,5	1813,19	1,7	MRN 62	16780	204,8	114,8	620,00	38,1707
	28,0	27,69	50,6	1998,33	1,6	MRN 62	6000	204,8	114,8	620,00	34,0539
	31,5	30,38	46,1	2189,42	1,4	MRN 62	7160	204,8	114,8	620,00	33,2259
	35,5	37,35	37,5	2685,92	0,9	MRN 62	16090	204,8	114,8	620,00	31,7360
	40,0	39,49	35,5	2855,60	1,1	MRN 62	18170	204,8	114,8	620,00	33,3872
38,2		36,7	2687,97	1,2	MRN 63	7350	211,0	121,0	620,00	22,6869	
50,0	48,44	28,9	3431,19	1,0	MRN 63	7670	211,0	121,0	620,00	22,2684	
15	6,3	5,64	248	553,69	2,0	MRN 52	7550	165,2	65,2	740,00	37,6347
		5,77	250	549,08	> 3,0	MRN 62	10060	214,8	114,8	740,00	84,0612
	7,1	7,46	188	732,56	1,7	MRN 52	8250	165,2	65,2	740,00	31,2885
		7,39	189	726,26	> 3,0	MRN 62	9540	214,8	114,8	740,00	68,0211
	8,0	7,66	183	753,30	1,5	MRN 52	8410	165,2	65,2	740,00	31,9539
		7,97	176	783,85	2,8	MRN 62	11380	214,8	114,8	740,00	68,6806
	9,0	9,46	148	929,20	1,5	MRN 52	8900	165,2	65,2	740,00	27,6749
		9,38	149	921,61	> 3,0	MRN 62	9030	214,8	114,8	740,00	56,8499
	10,0	10,13	138	997,11	1,2	MRN 52	9280	165,2	65,2	740,00	28,0395
		10,54	133	1034,48	2,1	MRN 62	12550	214,8	114,8	740,00	58,6662
	11,2	11,45	122	1123,19	1,4	MRN 52	8400	165,2	65,2	740,00	25,5151
		11,36	123	1115,11	2,8	MRN 62	5620	214,8	114,8	740,00	50,1639
	12,5	12,85	109	1262,59	0,9	MRN 52	10080	165,2	65,2	740,00	25,6545
	14,0	14,12	99,2	1387,93	1,2	MRN 52	8470	165,2	65,2	740,00	23,7029
		14	100	1373,91	2,3	MRN 62	5450	214,8	114,8	740,00	44,5468
	16,0	15,56	90	1525,86	0,8	MRN 52	10780	165,2	65,2	740,00	24,1384
		16,19	86,4	1591,98	1,4	MRN 62	11630	214,8	114,8	740,00	46,1997
	18,0	17,85	78,4	1758,99	0,9	MRN 52	8680	165,2	65,2	740,00	22,1741
		17,7	79,1	1739,13	1,8	MRN 62	3100	214,8	114,8	740,00	39,8027
	20,0	19,96	70,1	1956,90	1,2	MRN 62	15790	214,8	114,8	740,00	41,9382
22,4	23,25	60,2	2288,73	1,4	MRN 62	8000	214,8	114,8	740,00	35,8331	
25,0	25,24	55,5	2472,53	1,2	MRN 62	16780	214,8	114,8	740,00	38,1707	
28,0	27,69	50,6	2725,00	1,2	MRN 62	6000	214,8	114,8	740,00	34,0539	
31,5	30,38	46,1	2985,58	1,0	MRN 62	7160	214,8	114,8	740,00	33,2259	
40,0	39,49	35,5	3894,00	0,8	MRN 62	18170	214,8	114,8	740,00	33,3872	
	38,2	36,7	3665,41	0,9	MRN 63	7350	221,0	121,0	740,00	22,6869	
50,0	48,44	28,9	4678,90	0,7	MRN 63	7670	221,0	121,0	740,00	22,2684	
18,5	6,3	5,64	248	682,89	1,6	MRN 52	7550	185,2	65,2	1300,00	37,6347



## RN Riduttori - Gearboxes - Getriebe

Selezione Motoriduttore - Geared Motor Selection - Getriebemotorauswahl

1400 rpm

P <sub>1</sub> [kW]	i <sub>n</sub>	i <sub>r</sub>	N <sub>2</sub> [rpm]	M <sub>2</sub> [Nm]	FS	Tipo - Size - Größe	F <sub>r2</sub> [N]	MRN [kg]	FRN [kg]	J <sub>m</sub> × 10 <sup>-4</sup>	J <sub>1</sub> × 10 <sup>-4</sup>	
18,5	6,3	5,77	250	677,20	> 3,0	MRN 62	10060	234,8	114,8	1300,00	84,0612	
		7,1	7,46	188	903,49	1,4	MRN 52	8250	185,2	65,2	1300,00	31,2885
		7,39	189	895,72	2,9	MRN 62	9540	234,8	114,8	1300,00	68,0211	
	8,0	7,66	183	929,07	1,2	MRN 52	8410	185,2	65,2	1300,00	31,9539	
		7,97	176	966,75	2,3	MRN 62	11380	234,8	114,8	1300,00	68,6806	
	9,0	9,46	148	1146,02	1,2	MRN 52	8900	185,2	65,2	1300,00	27,6749	
		9,38	149	1136,65	2,6	MRN 62	9030	234,8	114,8	1300,00	56,8499	
	10,0	10,13	138	1229,77	0,9	MRN 52	9280	185,2	65,2	1300,00	28,0395	
		10,54	133	1275,86	1,7	MRN 62	12550	234,8	114,8	1300,00	58,6662	
	11,2	11,45	122	1385,27	1,1	MRN 52	8400	185,2	65,2	1300,00	25,5151	
		11,36	123	1375,30	2,3	MRN 62	5620	234,8	114,8	1300,00	50,1639	
	14,0	14,12	99,2	1711,78	0,9	MRN 52	8470	185,2	65,2	1300,00	23,7029	
		14	100	1694,49	1,9	MRN 62	5450	234,8	114,8	1300,00	44,5468	
	16,0	16,19	86,4	1963,44	1,1	MRN 62	11630	234,8	114,8	1300,00	46,1997	
	18,0	17,7	79,1	2144,93	1,5	MRN 62	3100	234,8	114,8	1300,00	39,8027	
	20,0	19,96	70,1	2413,51	0,9	MRN 62	15790	234,8	114,8	1300,00	41,9382	
	22,4	23,25	60,2	2822,77	1,2	MRN 62	8000	234,8	114,8	1300,00	35,8331	
	25,0	25,24	55,5	3049,45	1,0	MRN 62	16780	234,8	114,8	1300,00	38,1707	
28,0	27,69	50,6	3360,83	1,0	MRN 62	6000	234,8	114,8	1300,00	34,0539		
31,5	30,38	46,1	3682,21	0,8	MRN 62	7160	234,8	114,8	1300,00	33,2259		
22	6,3	5,64	248	812,08	1,4	MRN 52	7550	200,2	65,2	1500,00	37,6347	
		5,77	250	805,32	2,7	MRN 62	10060	249,8	114,8	1500,00	84,0612	
	7,1	7,46	188	1074,42	1,2	MRN 52	8250	200,2	65,2	1500,00	31,2885	
		7,39	189	1065,18	2,4	MRN 62	9540	249,8	114,8	1500,00	68,0211	
	8,0	7,66	183	1104,85	1,0	MRN 52	8410	200,2	65,2	1500,00	31,9539	
		7,97	176	1149,64	1,9	MRN 62	11380	249,8	114,8	1500,00	68,6806	
	9,0	9,46	148	1362,83	1,0	MRN 52	8900	200,2	65,2	1500,00	27,6749	
		9,38	149	1351,69	2,1	MRN 62	9030	249,8	114,8	1500,00	56,8499	
	10,0	10,13	138	1462,43	0,8	MRN 52	9280	200,2	65,2	1500,00	28,0395	
		10,54	133	1517,24	1,5	MRN 62	12550	249,8	114,8	1500,00	58,6662	
	11,2	11,45	122	1647,34	0,9	MRN 52	8400	200,2	65,2	1500,00	25,5151	
		11,36	123	1635,49	1,9	MRN 62	5620	249,8	114,8	1500,00	50,1639	
	14,0	14,12	99,2	2035,63	0,8	MRN 52	8470	200,2	65,2	1500,00	23,7029	
		14	100	2015,07	1,6	MRN 62	5450	249,8	114,8	1500,00	44,5468	
	16,0	16,19	86,4	2334,91	1,0	MRN 62	11630	249,8	114,8	1500,00	46,1997	
	18,0	17,7	79,1	2550,72	1,3	MRN 62	3100	249,8	114,8	1500,00	39,8027	
	20,0	19,96	70,1	2870,11	0,8	MRN 62	15790	249,8	114,8	1500,00	41,9382	
	22,4	23,25	60,2	3356,81	1,0	MRN 62	8000	249,8	114,8	1500,00	35,8331	
25,0	25,24	55,5	3626,37	0,8	MRN 62	16780	249,8	114,8	1500,00	38,1707		
28,0	27,69	50,6	3996,67	0,8	MRN 62	6000	249,8	114,8	1500,00	34,0539		
31,5	30,38	46,1	4378,85	0,7	MRN 62	7160	249,8	114,8	1500,00	33,2259		

## Getriebe - Gearboxes - Riduttori RN

Motorkurzreferenz Tabelle - Motor Quick-Reference Chart - Tabella di Riferimento Rapido Motori

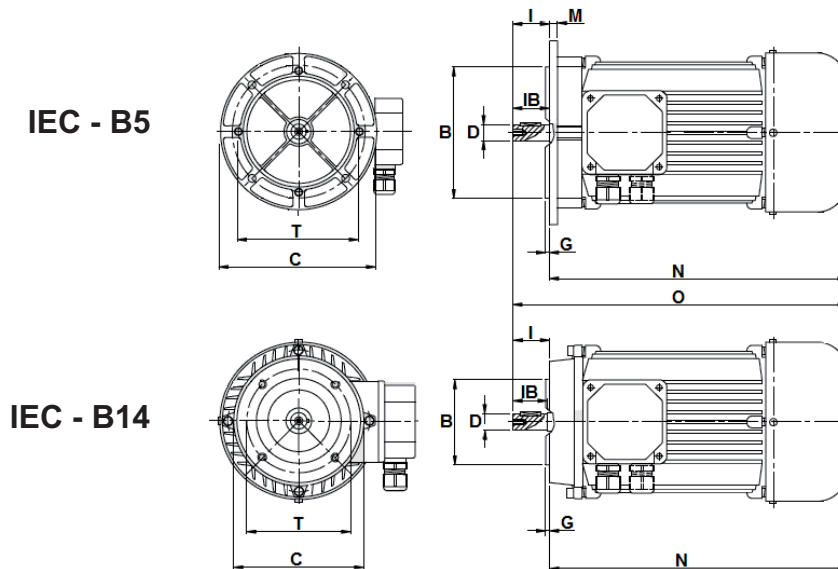

Taglia Frame Größe	4 poli - poles - polen			2 poli - poles - polen			Flangia - Flange - Flansch  C / T / B	Albero Shaft Welle  D x l	G	IB	M	N	O
	kW	rpm	kg (B3)	kW	rpm	kg (B3)							
T56A	0.06	1410	2.5	0.09	2730	2.6	B5 - 120 / 100 / 80	9 x 20	2.5	20	8.5	168	188
T56B	0.09	1340	2.6	0.14	2750	3.2	B14 - 80 / 65 / 50						
T63A	0.13	1340	3.7	0.18	2770	3.7	B5 - 140 / 115 / 95	11 x 23	2.5	23	10	190.5	213.5
T63B	0.18	1360	4.3	0.25	2820	4.3	B14 - 90 / 75 / 60						
T71A	0.25	1410	5.8	0.37	2860	5.8	B5 - 160 / 130 / 110	14 x 30	3.0	30	10	218	248
T71B	0.37	1370	6.2	0.55	2860	6.2	B14 - 105 / 85 / 70						
T80A	0.55	1430	8.5	0.75	2860	8.5	B5 - 200 / 165 / 130	19 x 40	3.0	40	11	248	282
T80B	0.75	1430	9.8	1.1	2850	9.8	B14 - 120 / 100 / 80						
T90S	1.1	1430	12.0	1.5	2880	12.0	B5 - 200 / 165 / 130	24 x 50	3.5	50	10	255	305
T90L	1.5	1430	13.5	2.2	2850	13.5	B14 - 140 / 115 / 95						
T100A	2.2	1430	19.0	3	2910	18.5	B5 - 250 / 215 / 180	28 x 60	4.0	60	14	312	372
T100B	3	1430	21.0	4	2920	21.0	B14 - 160 / 130 / 110						
T112A	4	1440	29.0	5.5	2920	32.0	B5 - 250 / 215 / 180 B14 - 160 / 130 / 110	28 x 60	4.0	60	14	330	390
T132S	5.5	1460	43	7.5	2920	48	B5 - 300 / 265 / 230 B14 - 200 / 165 / 130	38 x 80	4.0	80	20	380.5	460.5
T132M	7.5	1460	52	11	2940	54							
T132ML	9.2	1460	54	15	2940	58							
T160M	11	1470	90	---	---	---	B5 - 350 / 300 / 250	42 x 110	5.0	110	20	491	601
T160L	15	1480	100	18.5	2960	99	B14 - 250 / 215 / 180						
T180M	18.5	1470	120	22	2940	110	B% - 350 / 300 / 250	48 x 110	5.0	110	20	610	720
T180L	22	1480	135	---	---	---							

Dimensioni e pesi non impegnativi

Not binding dimensions and weights

unverbindliche Abmessungen u. Gewichte

**MRN  
FRN**

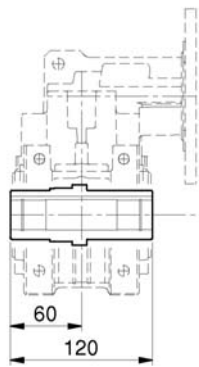
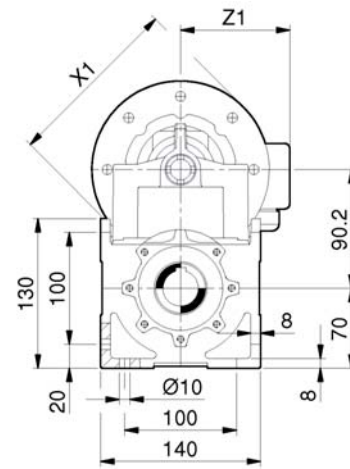
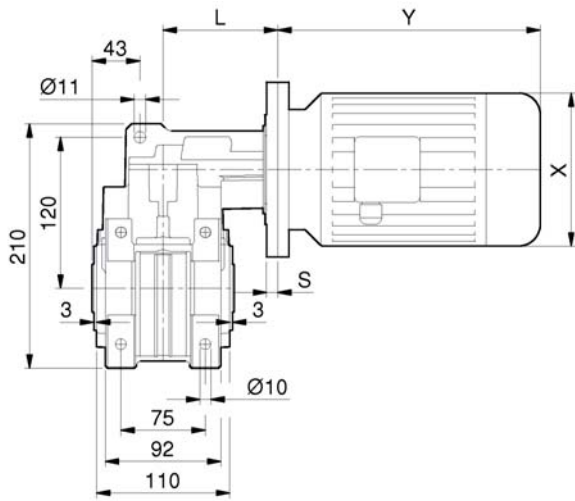

**AC30 AC25**

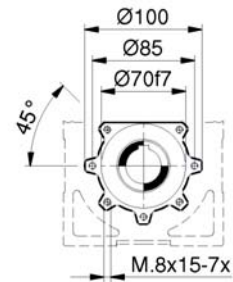
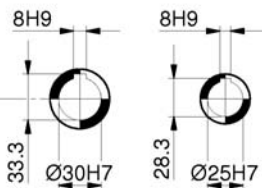

**SRN**

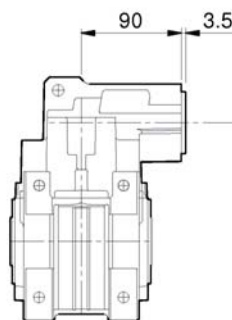

**RN**

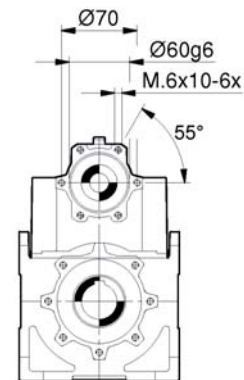
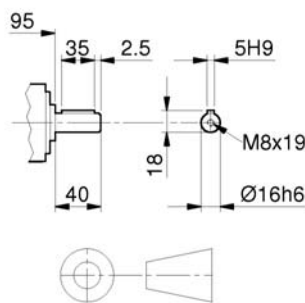

RN	12 / 13	12 / 13	12 / 13	12	12	12	
IEC	56	63	71	80	90 S	90 L	
X / Y / Z1	110/168/108	123/185/110	140/220/121	159/238/138	176/255/149	176/280/149	
X1 (B5) / S	120/13	140/13	160/13,5	200/13,5	---	---	
X1 (B14) / S	---	90/13	105/18,5	120/13,5	140/13,5	140/13,5	
L (RN12)	103	103	103,5 (108,5)	103,5	103,5	103,5	
L (RN13)	103	103	103,5 (108,5)	---	---	---	

Dimensioni e pesi non impegnativi

Not binding dimensions and weights

unverbindliche Abmessungen u. Gewichte

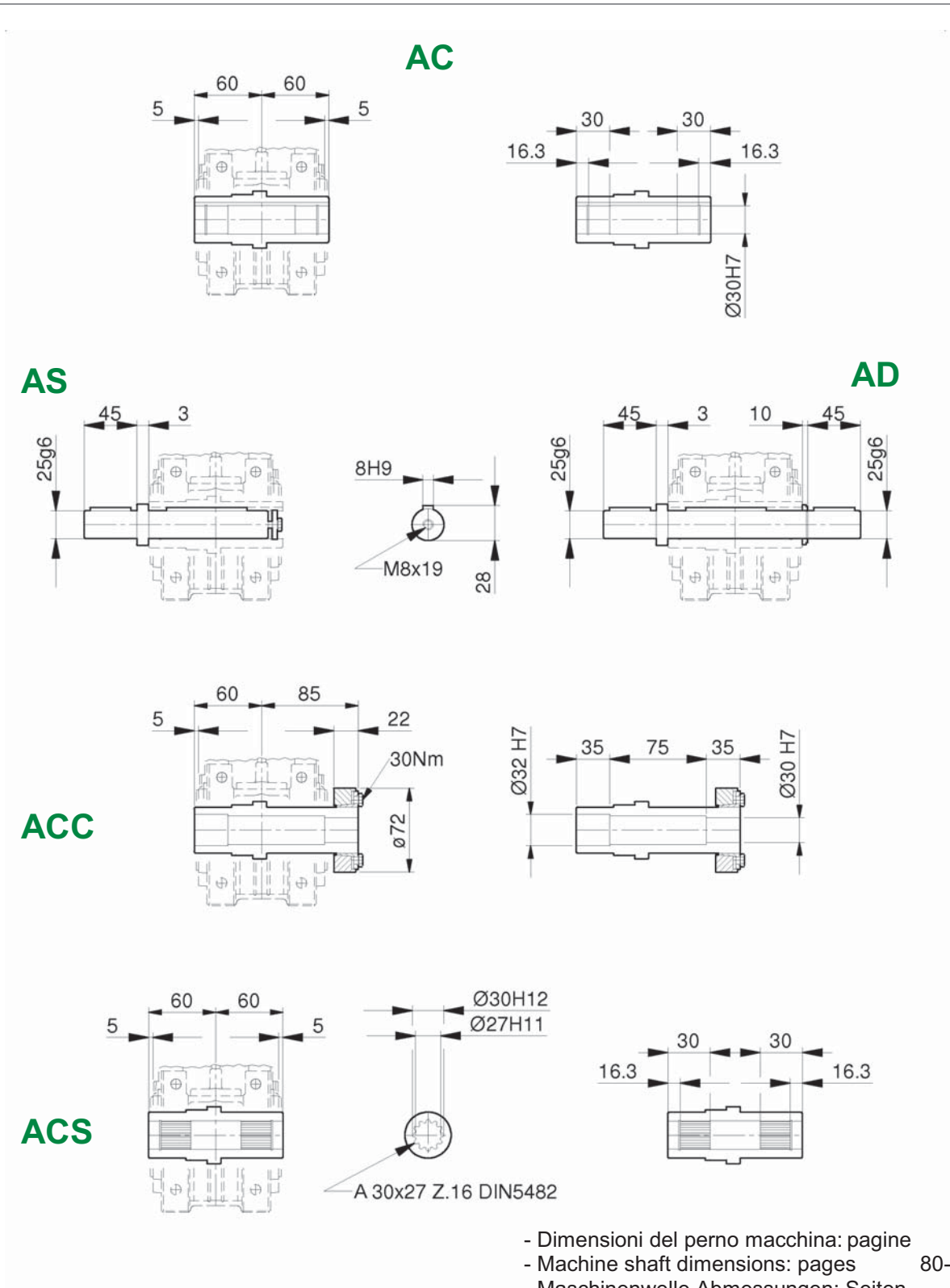

- Dimensioni del perno macchina: pagine  
 - Machine shaft dimensions: pages 80-82  
 - Maschinenwelle Abmessungen: Seiten

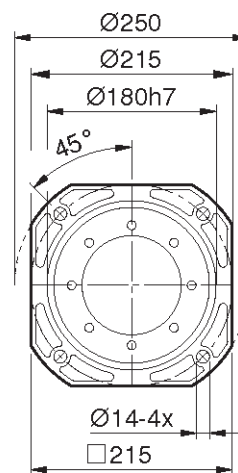
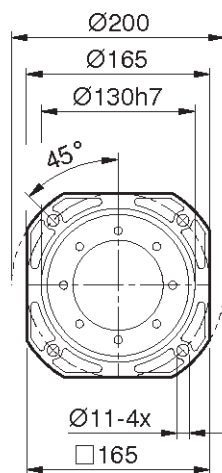
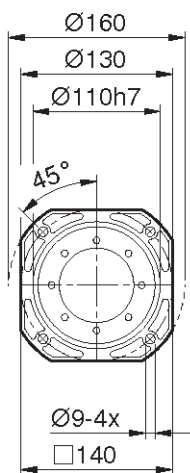
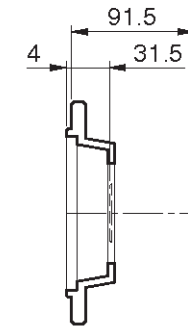
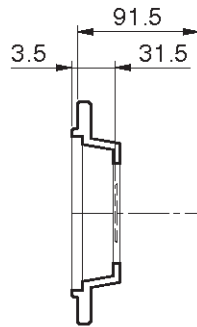
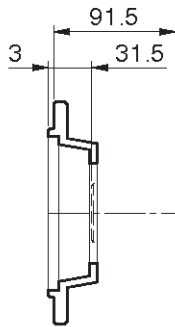
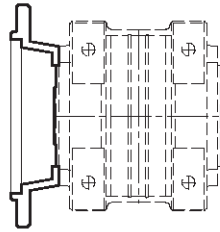

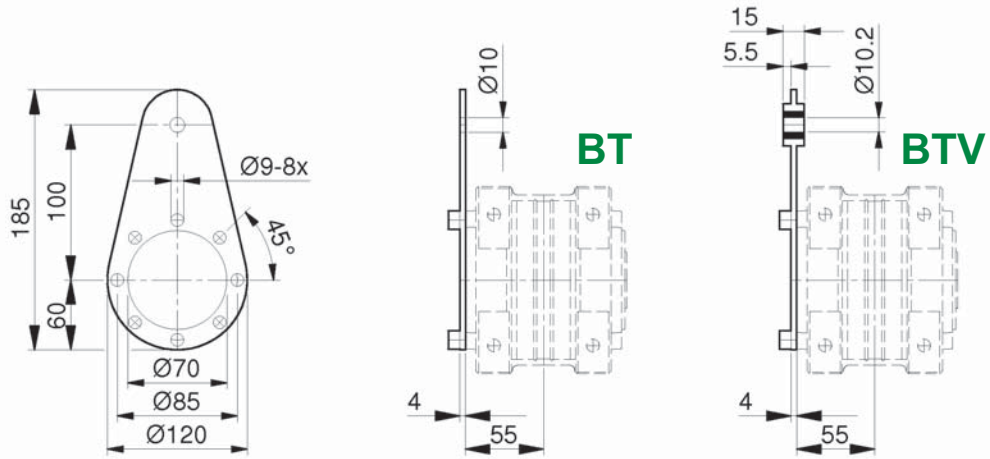

**BTA**

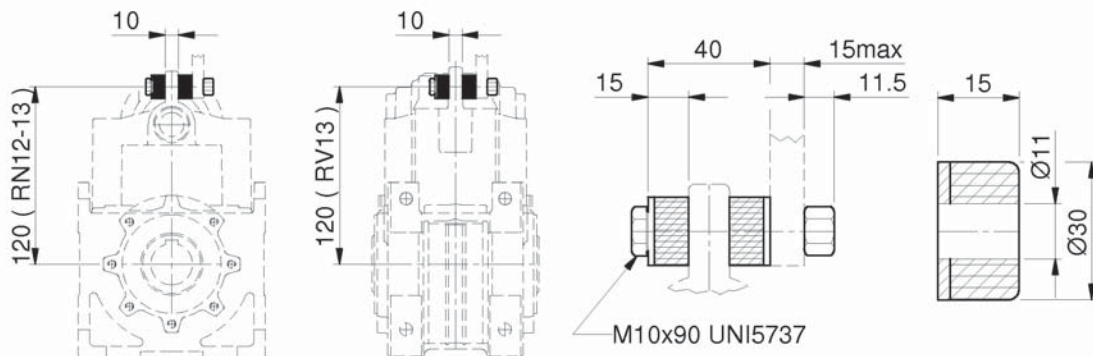

**BTF**

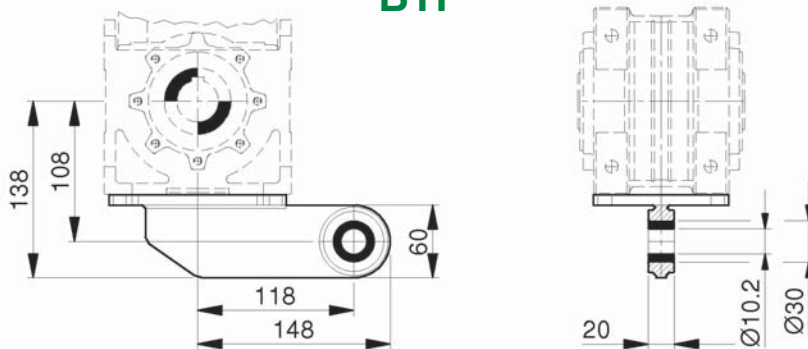



**MRN  
FRN**

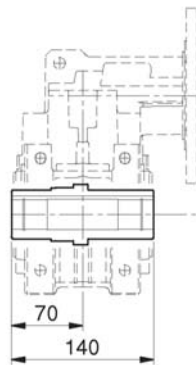
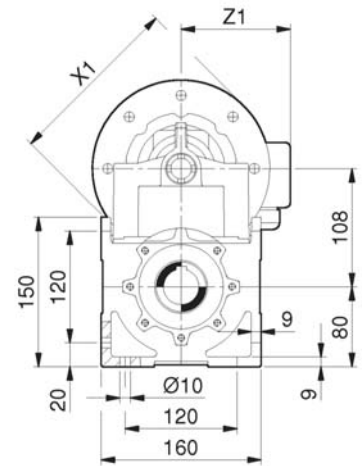
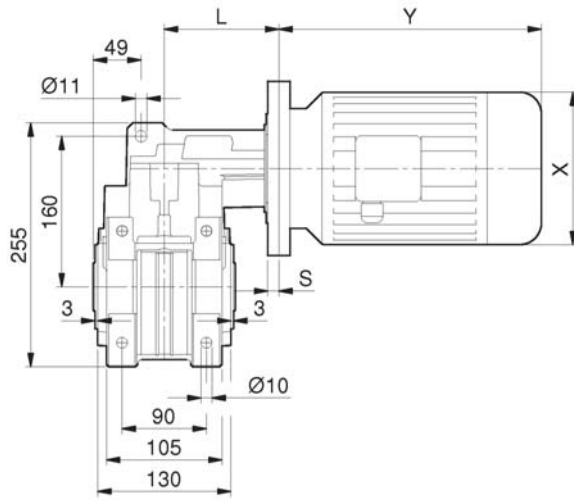

**AC35**

**AC30**

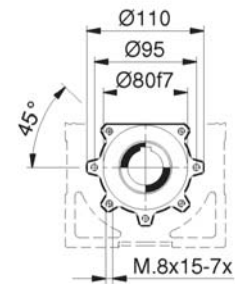
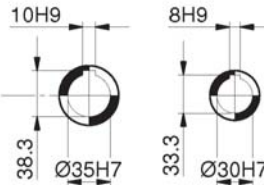

**SRN**

**RN**

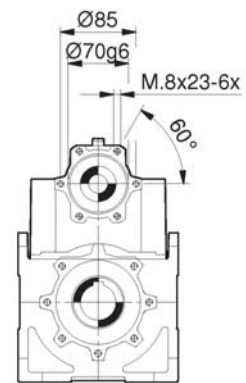
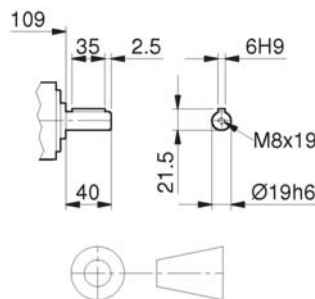
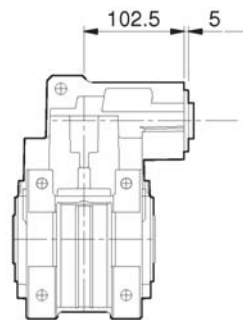

RN	22 / 23	22 / 23	22	22	22	22	
IEC	71	80	90 S	90 L	100	112	
X / Y / Z1	140/220/121	159/238/138	176/255/149	176/280/149	195/314/160	219/328/172	
X1 (B5) / S	160/15,5	200/15,5	200/15,5	200/15,5	250/16,5	250/16,5	
X1 (B14) / S	105/15,5	120/17,5	140/17,5	140/17,5	160/15,5	160/15,5	
L (RN22)	118	118 (120)	118 (120)	118 (120)	119 (118)	119 (118)	
L (RN23)	118	118 (120)	---	---	---	---	

Dimensioni e pesi non impegnativi

Not binding dimensions and weights

unverbindliche Abmessungen u. Gewichte

**AC**

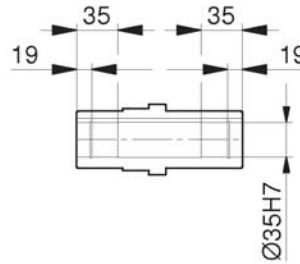
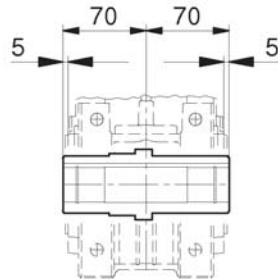

**AS**

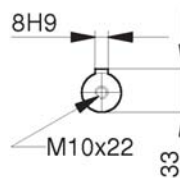
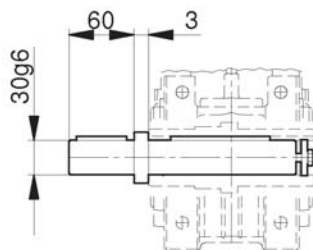

**AD**

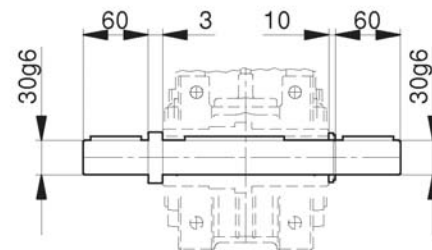

**ACC**

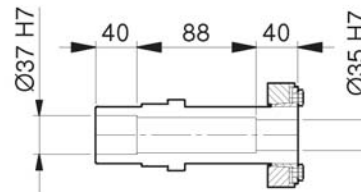
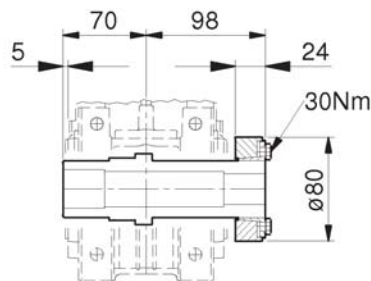

**ACS**

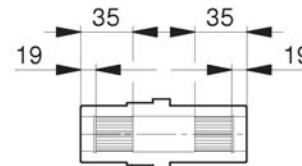
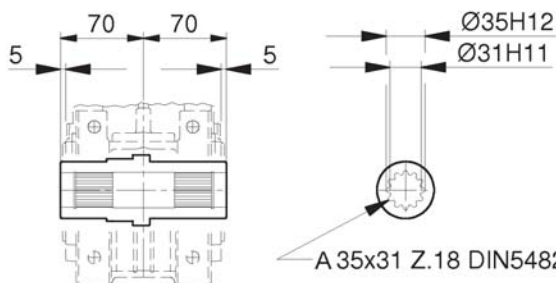

- Dimensioni del perno macchina: pagine
- Machine shaft dimensions: pages 80-82
- Maschinenwelle Abmessungen: Seiten

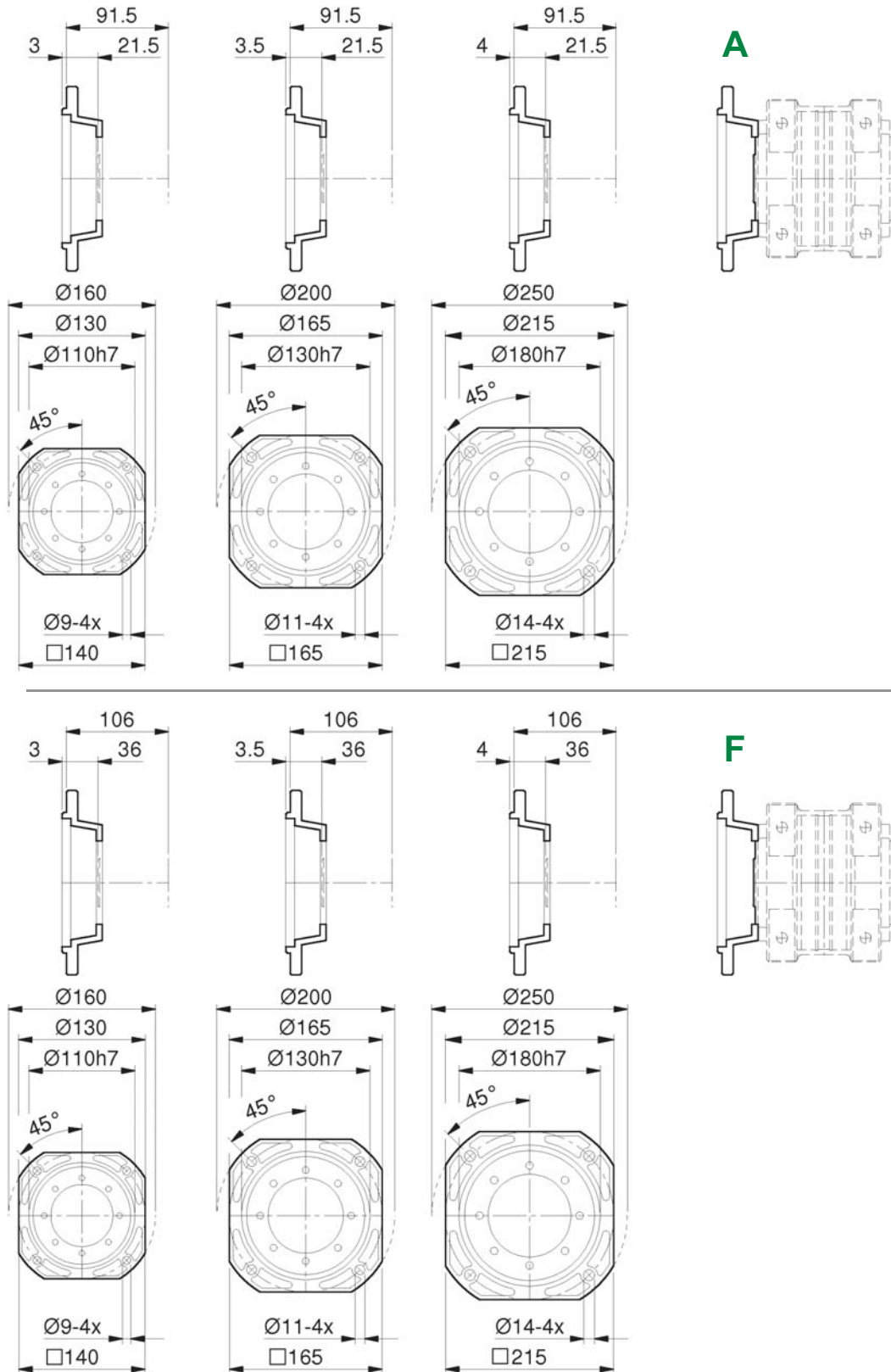

Dimensioni e pesi non impegnativi

Not binding dimensions and weights

unverbindliche Abmessungen u. Gewichte

# RN22-23

# Getriebe - Gearboxes - Riduttori RN

Abmessungen - Dimensions - Dimensioni

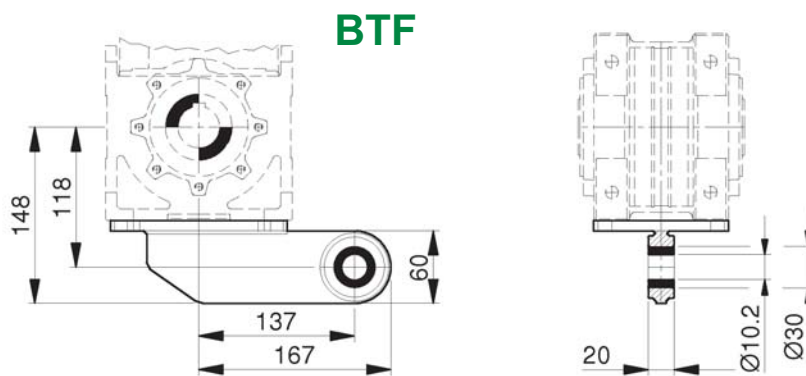
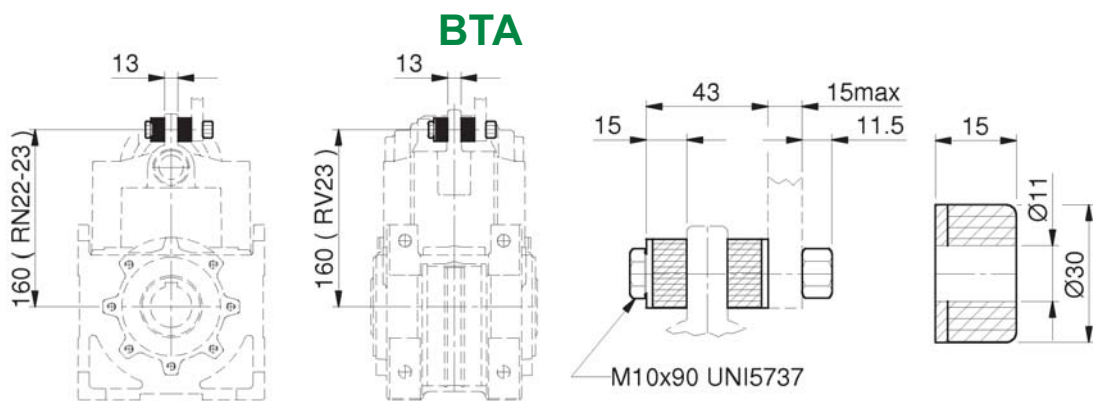
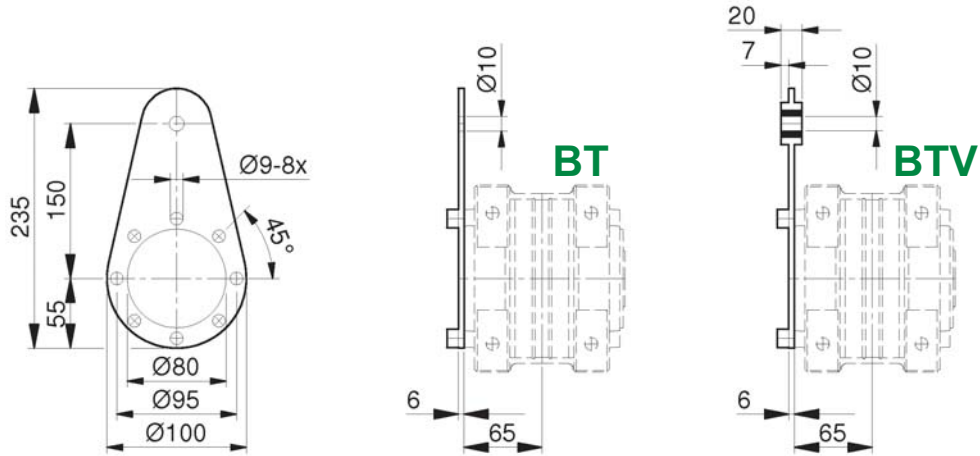

Dimensioni e pesi non impegnativi

Not binding dimensions and weights

unverbindliche Abmessungen u. Gewichte

**MRN  
FRN**

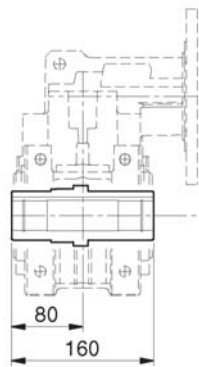
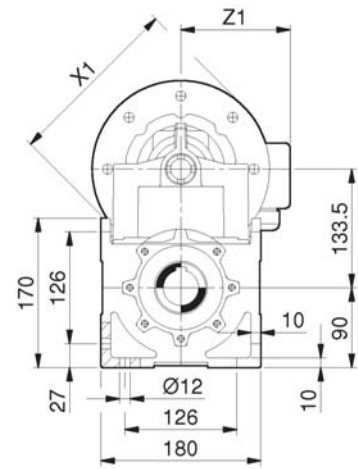
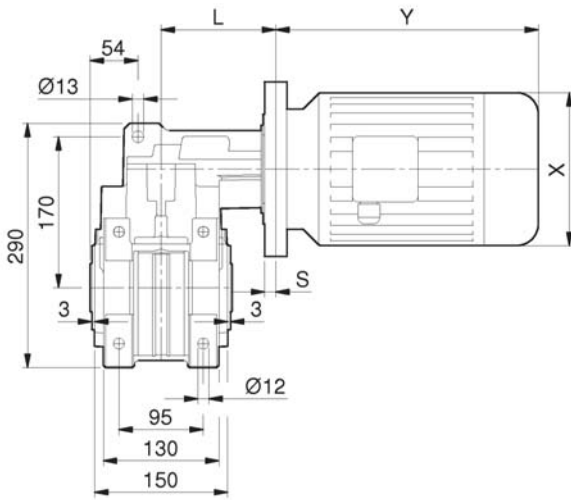

**AC40**



**AC35**

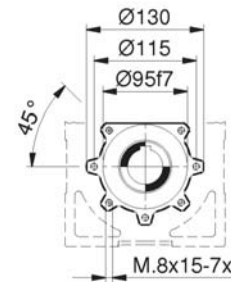
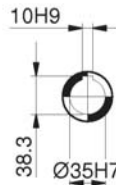

**SRN**

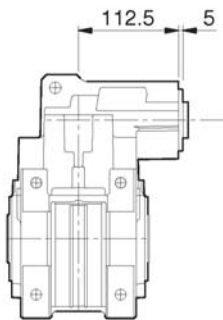

**RN**

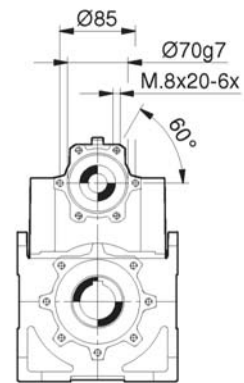
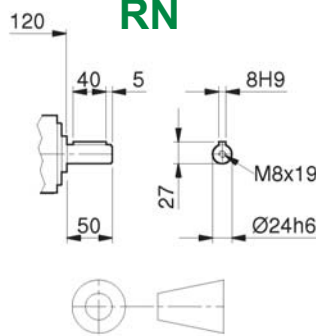

RN	32 / 33	32 / 33	32 / 33	32 / 33	32	32	
IEC	71	80	90 S	90 L	100	112	
X / Y / Z1	140/220/121	159/238/138	176/255/149	176/280/149	195/314/160	219/328/172	
X1 (B5) / S	160/15,5	200/15,5	200/15,5	200/15,5	250/16,5	250/16,5	
X1 (B14) / S	105/15,5	120/17,5	140/17,5	140/17,5	160/15,5	160/15,5	
L (RN32)	128	128 (130)	128 (130)	128 (130)	129 (128)	129 (128)	
L (RN33)	128	128 (130)	128 (130)	128 (130)	---	---	

Dimensioni e pesi non impegnativi

Not binding dimensions and weights

unverbindliche Abmessungen u. Gewichte

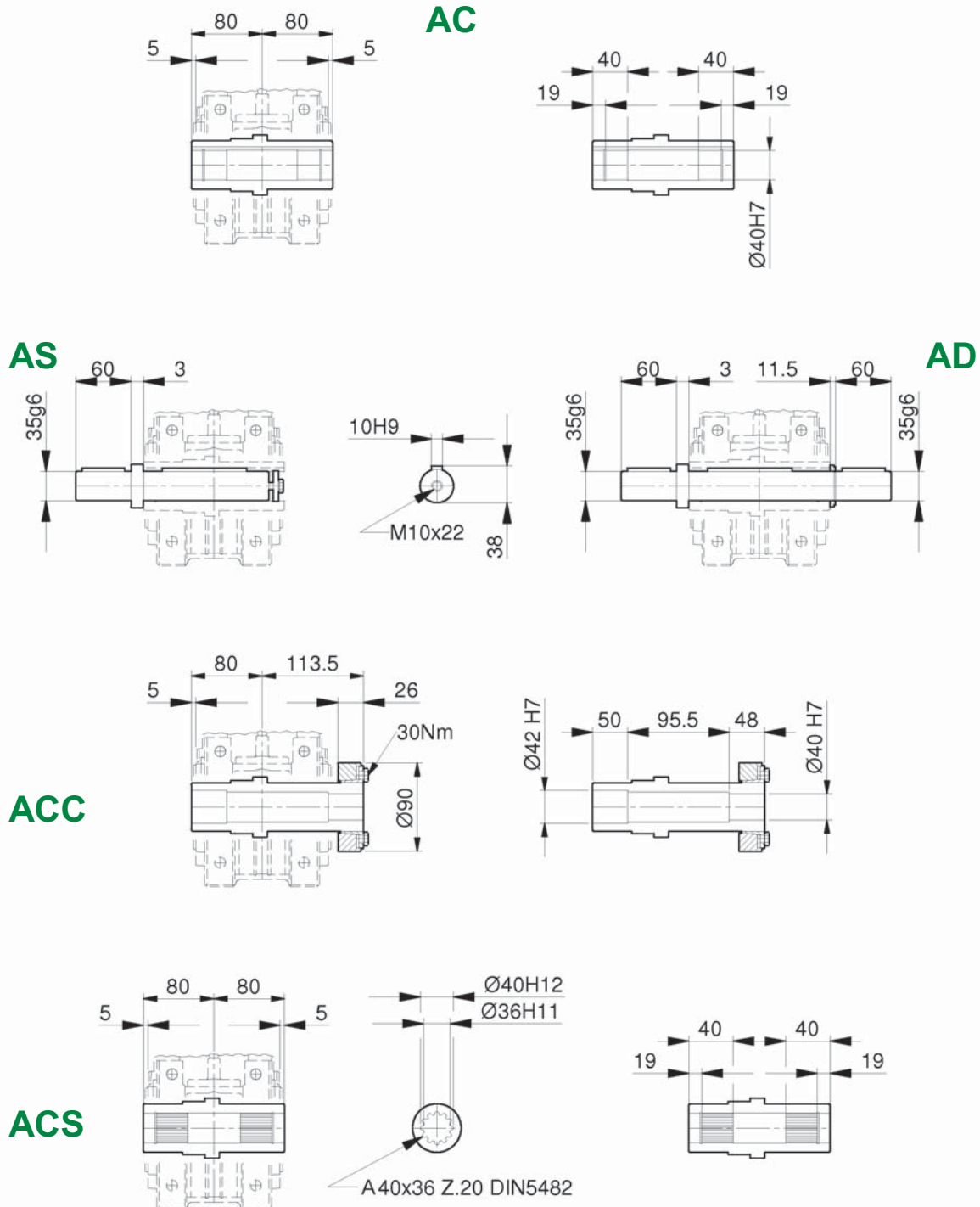

- Dimensioni del perno macchina: pagine
- Machine shaft dimensions: pages 80-82
- Maschinenwelle Abmessungen: Seiten



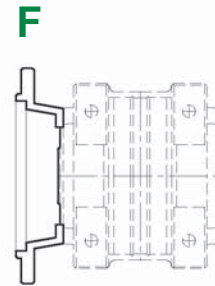
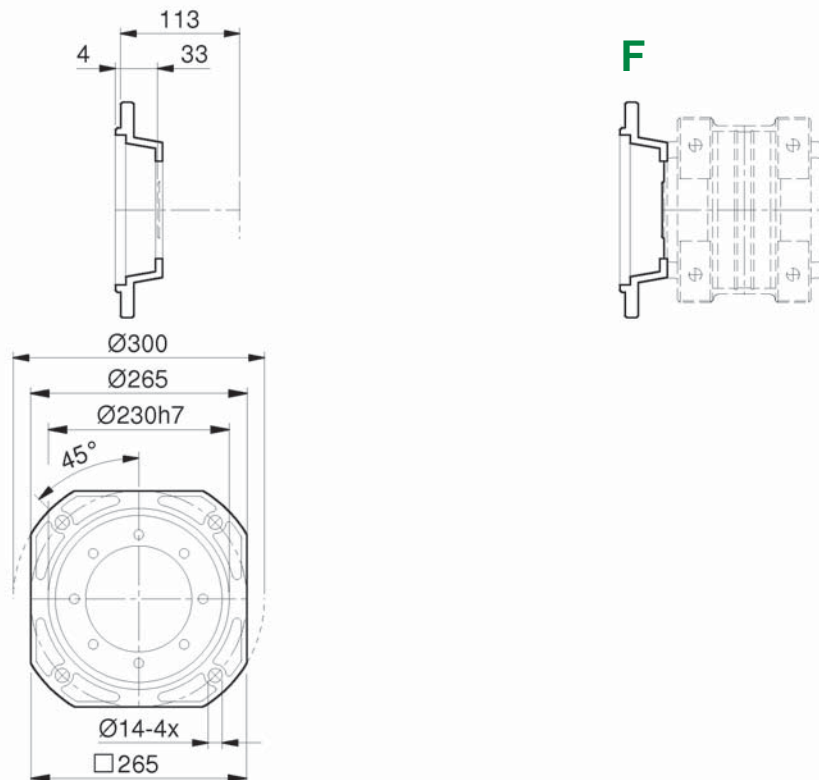
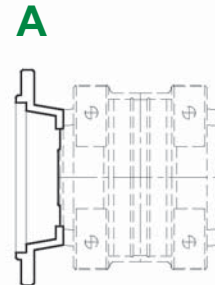
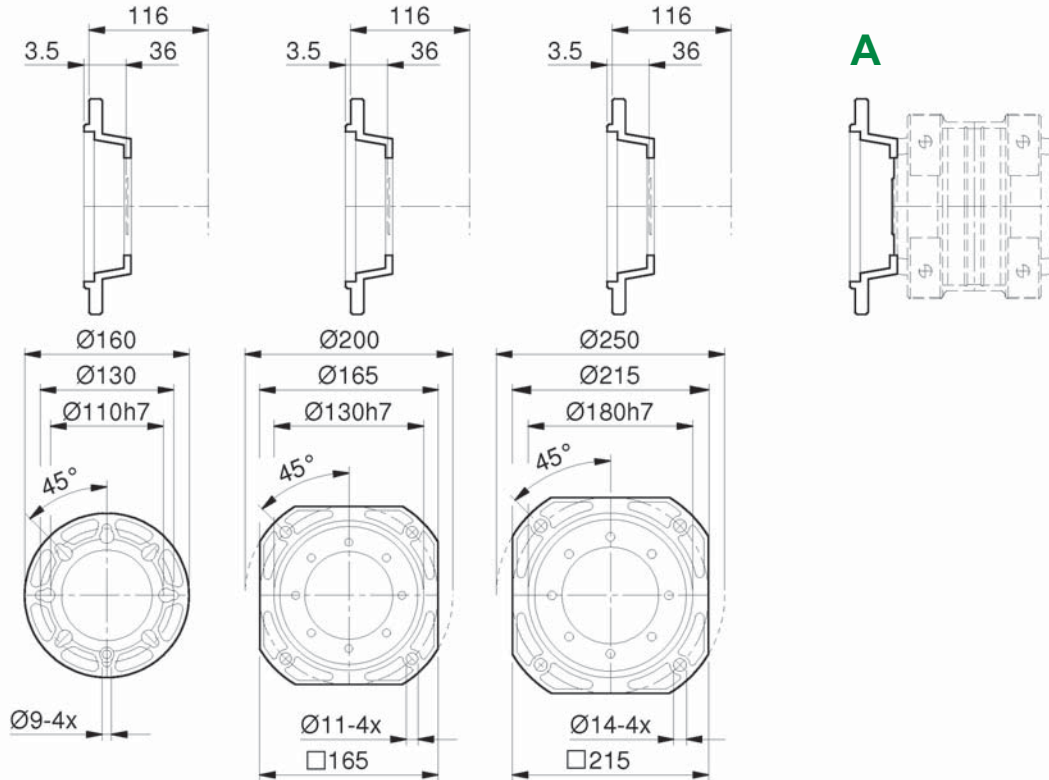

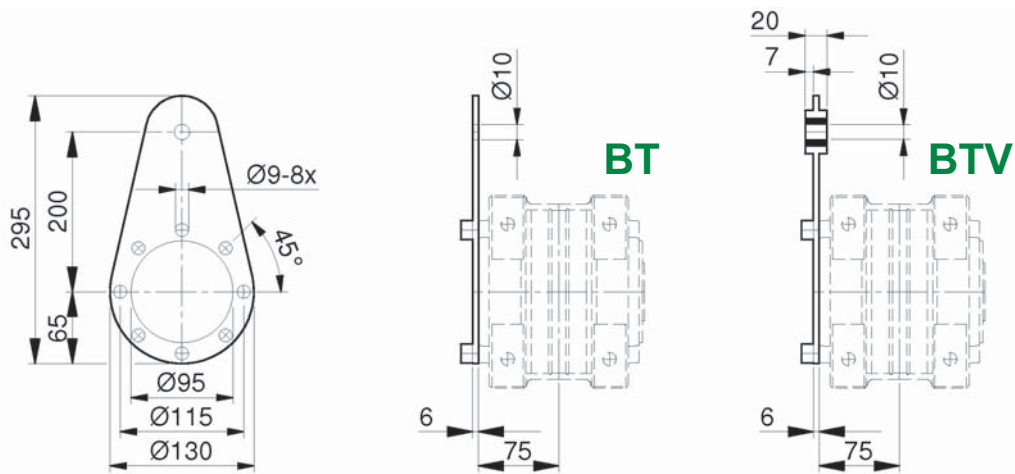

**BTA**

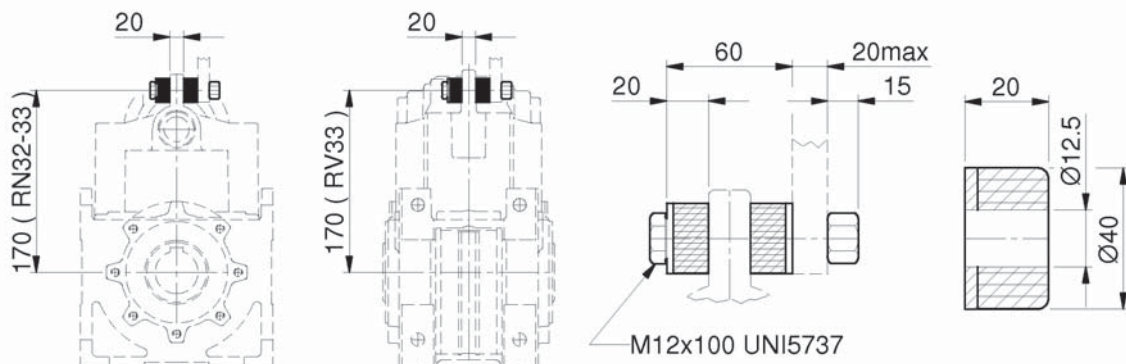

**BTF**

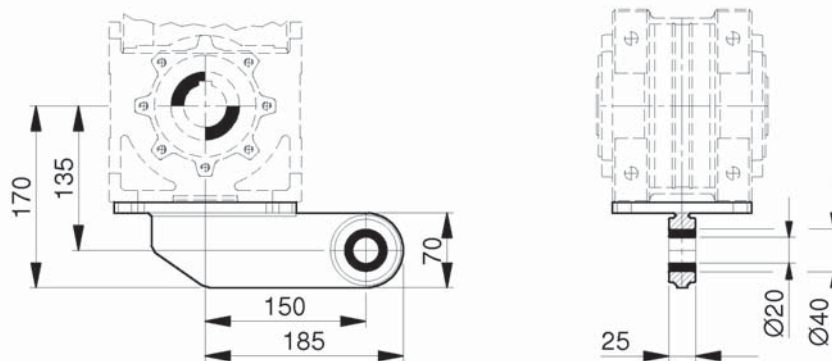

# RN Riduttori - Gearboxes - Getriebe

## RN42-43

Dimensioni - Dimensions - Abmessungen

**MRN  
FRN**

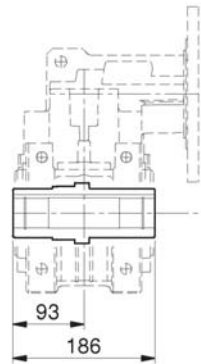
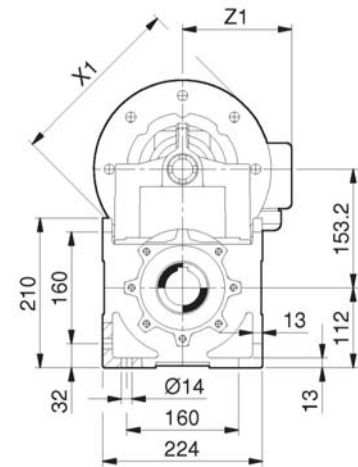
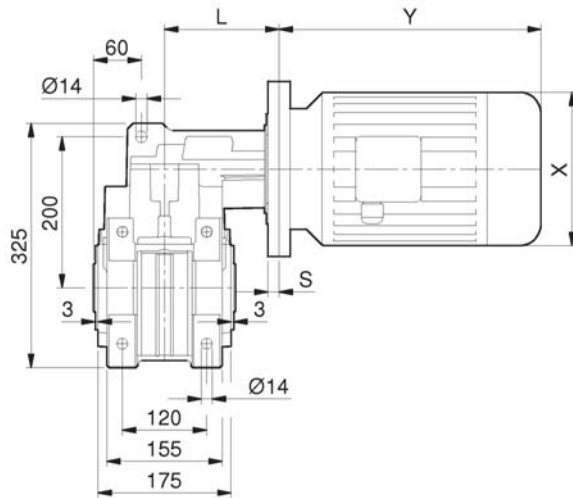

**AC50**

**AC45**

**AC40**

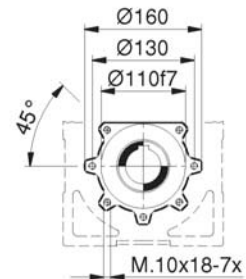
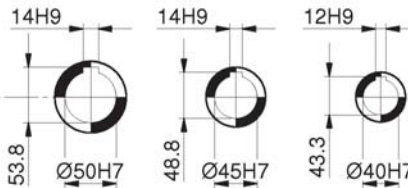

**SRN**

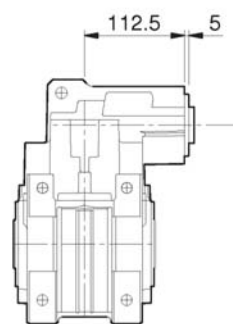

**RN**

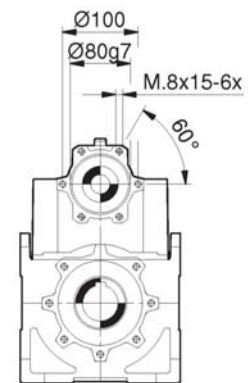
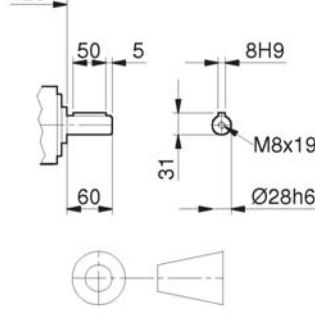

RN	42 / 43	42 / 43	42 / 43	42 / 43	42 / 43	42	
IEC	71	80	90 S	90 L	100	112	
X / Y / Z1	140/220/121	159/238/138	176/255/149	176/280/149	195/314/160	219/328/172	
X1 (B5) / S	160/15,5	200/15,5	200/15,5	200/15,5	250/16,5	250/16,5	
X1 (B14) / S	---	120/15,5	---	---	160/15,5	160/15,5	
L (RN42)	148	148	148 (151)	148 (151)	149 (148)	149 (148)	
L (RN43)	148	148	148 (151)	148 (151)	149 (148)	---	

Dimensioni e pesi non impegnativi

Not binding dimensions and weights

unverbindliche Abmessungen u. Gewichte

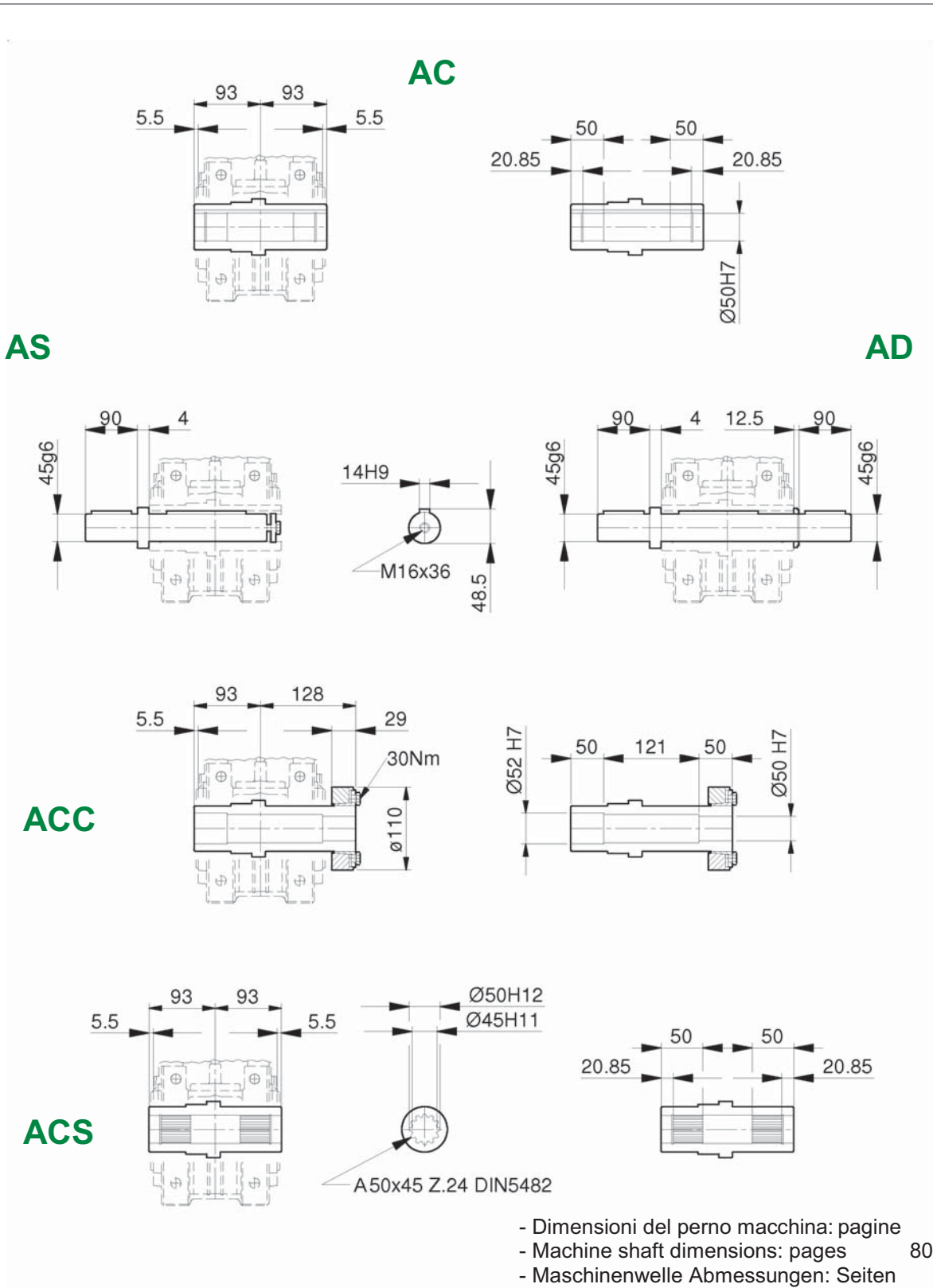

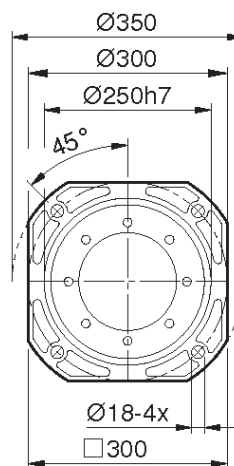
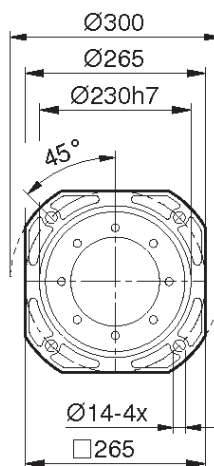
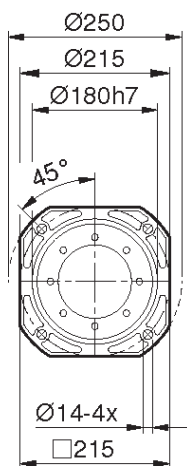
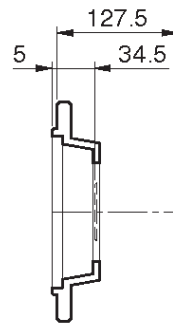
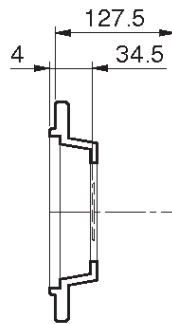
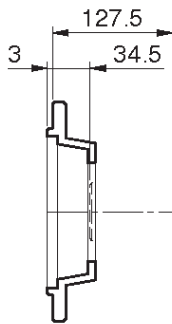
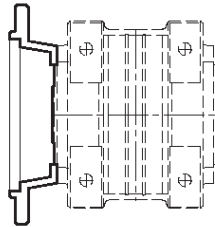

# RN42-43

# Getriebe - Gearboxes - Riduttori RN

Abmessungen - Dimensions - Dimensioni

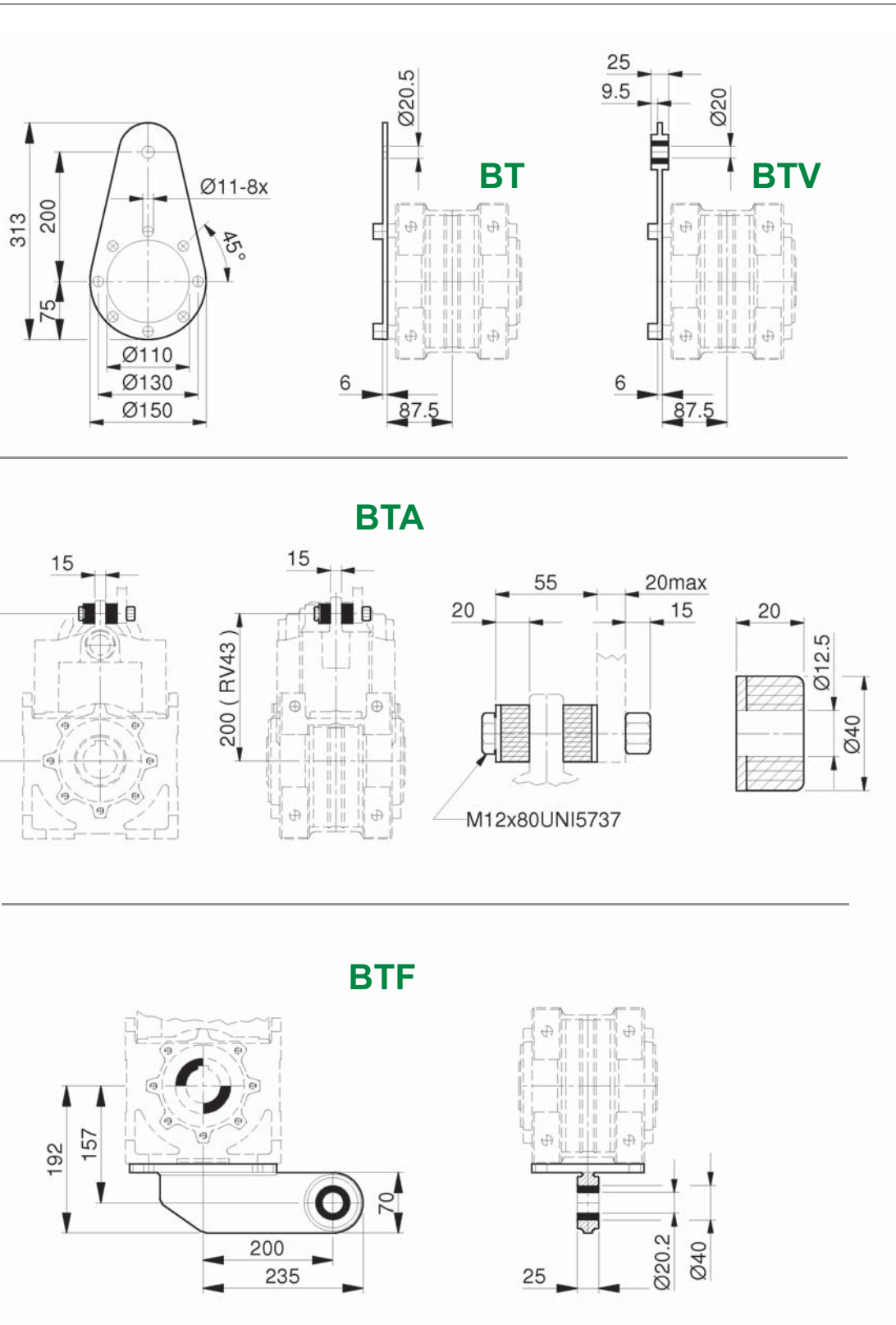

Dimensioni e pesi non impegnativi

Not binding dimensions and weights

unverbindliche Abmessungen u. Gewichte



# RN Riduttori - Gearboxes - Getriebe

## RN52-53

Dimensioni - Dimensions - Abmessungen

**MRN  
FRN**

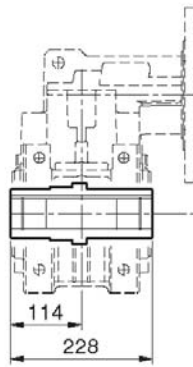
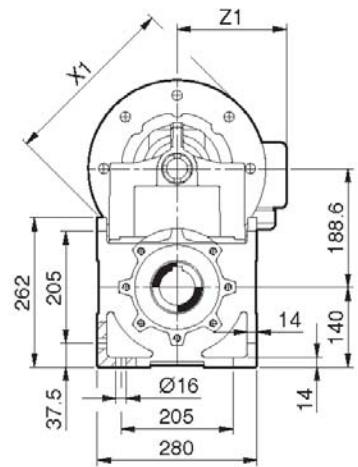
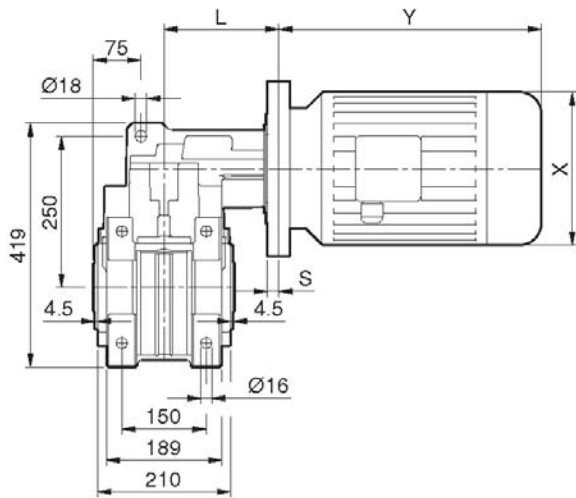

**AC60**

**AC55**

**AC50**

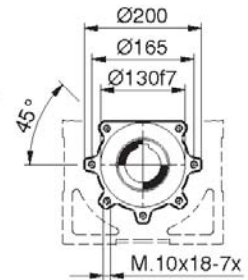
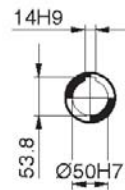
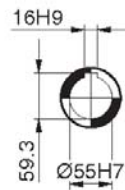

**SRN**

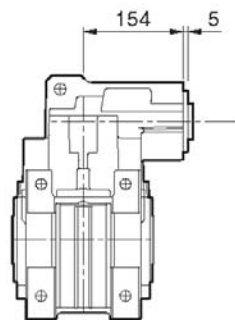

**RN**

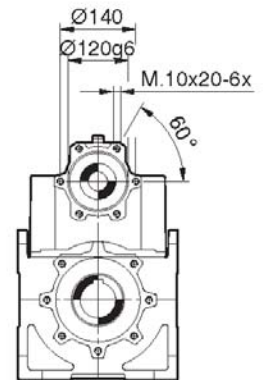
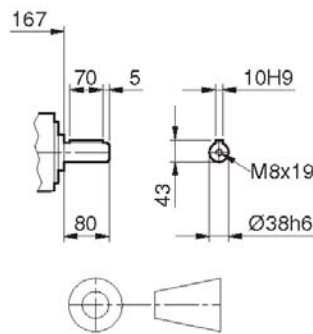

RN	52 / 53	52 / 53	52 / 53	52 / 53	52 / 53	52	52
IEC	80	90 S / L	100	112	132 S / M	160	180
X / Y / Z1	159/238/138	176/255-280/149	195/314/160	219/328/172	258/368-410/192	310/486/235	320/580/245
X1 (B5) / S	200/22	200/22	250/22	250/22	300/22	350/35	350/35
X1 (B14) / S	---	---	---	---	200/22	250/22	300/22
L (RN52)	176	176	176	176	176	189 (176)	189 (176)
L (RN53)	176	176	176	176	176	---	---

Dimensioni e pesi non impegnativi

Not binding dimensions and weights

unverbindliche Abmessungen u. Gewichte

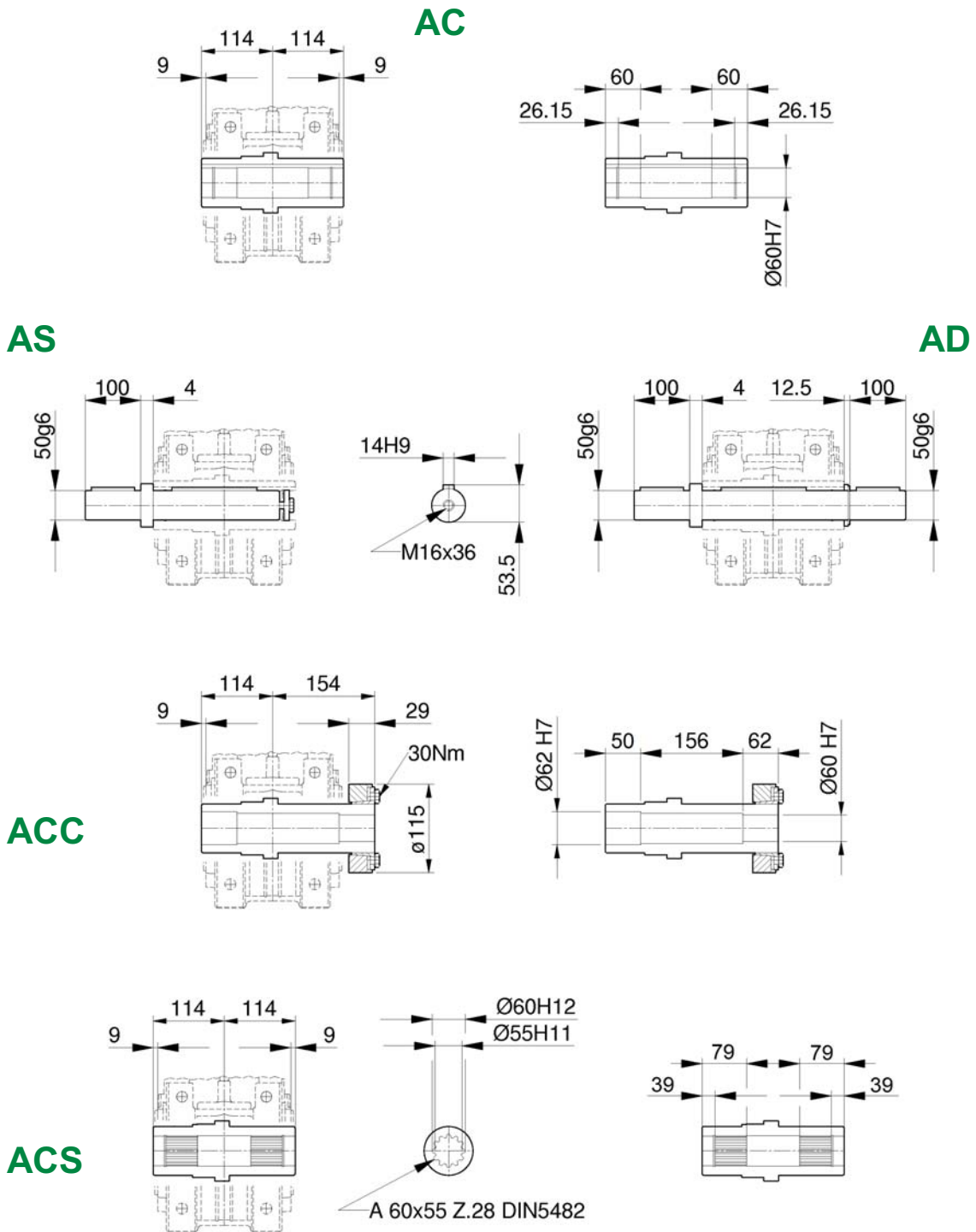

- Dimensioni del perno macchina: pagine
- Machine shaft dimensions: pages 80-82
- Maschinenwelle Abmessungen: Seiten

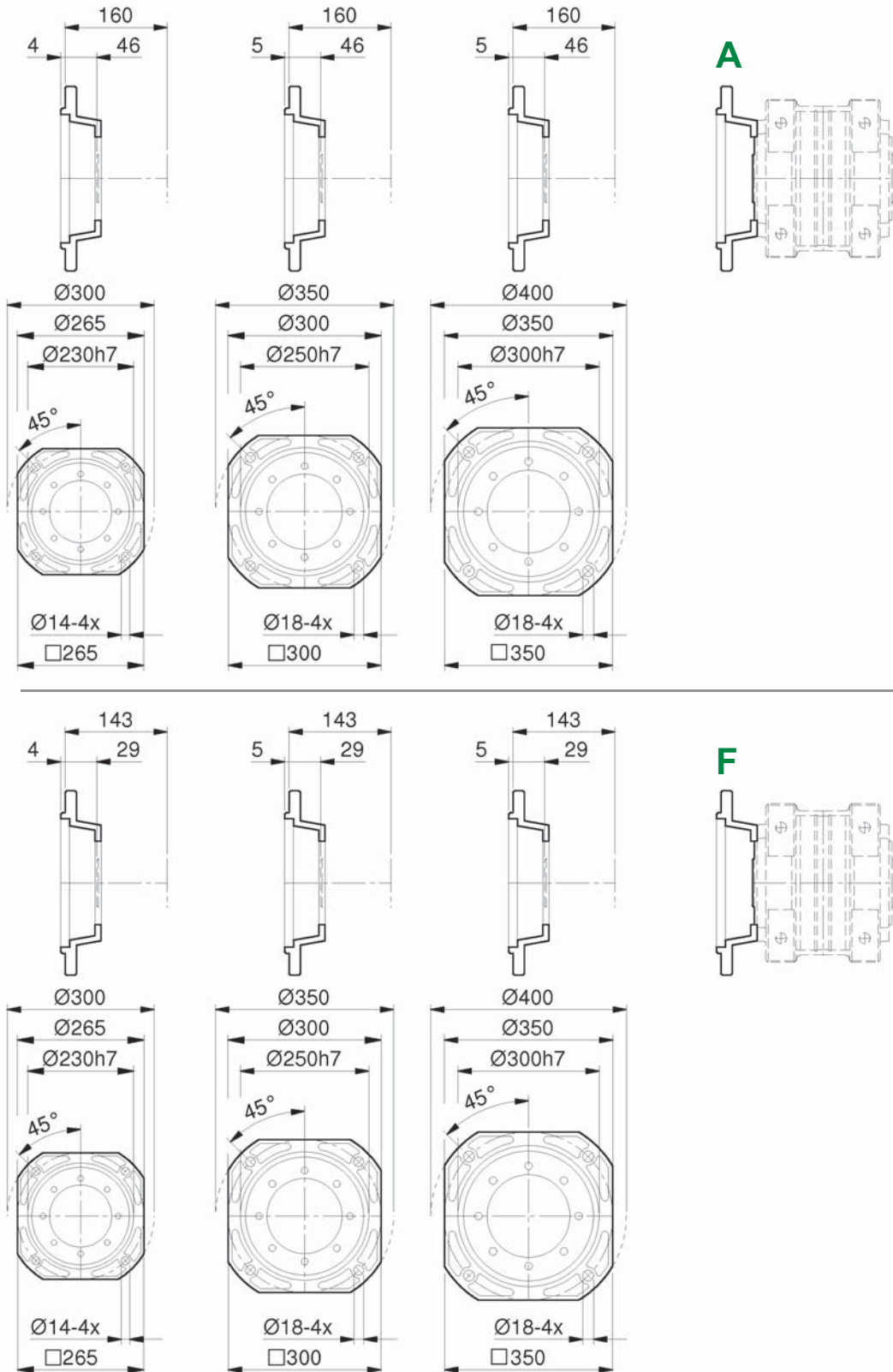

Dimensioni e pesi non impegnativi

Not binding dimensions and weights

unverbindliche Abmessungen u. Gewichte

# RN52-53

# Getriebe - Gearboxes - Riduttori RN

Abmessungen - Dimensions - Dimensioni

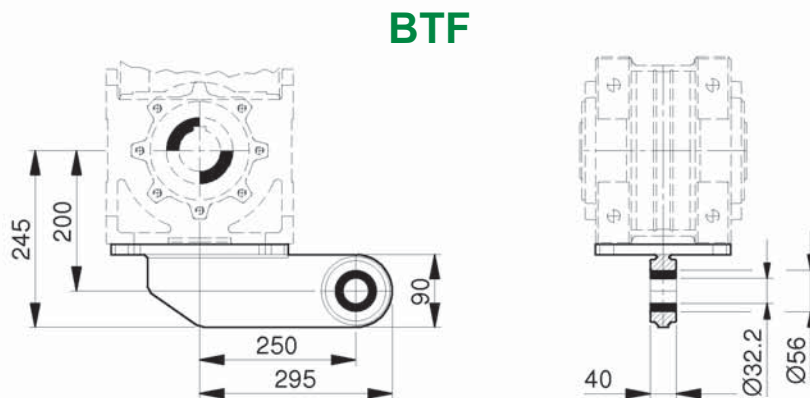
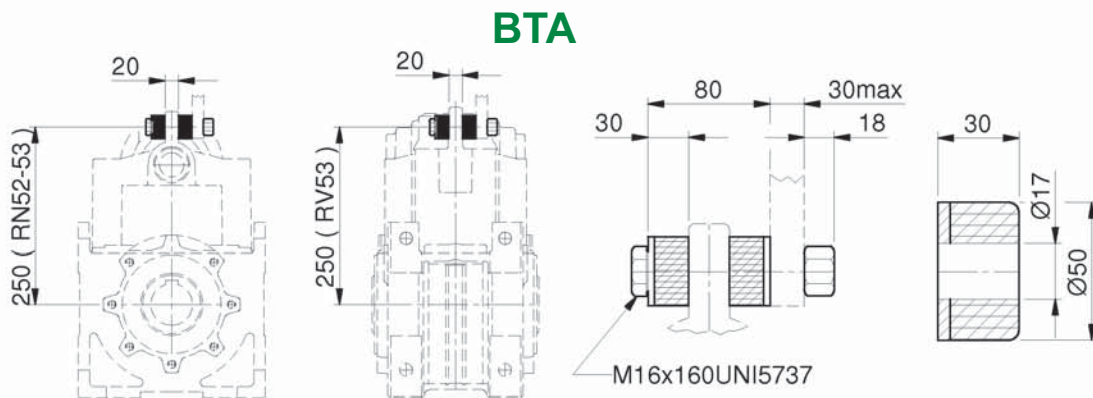
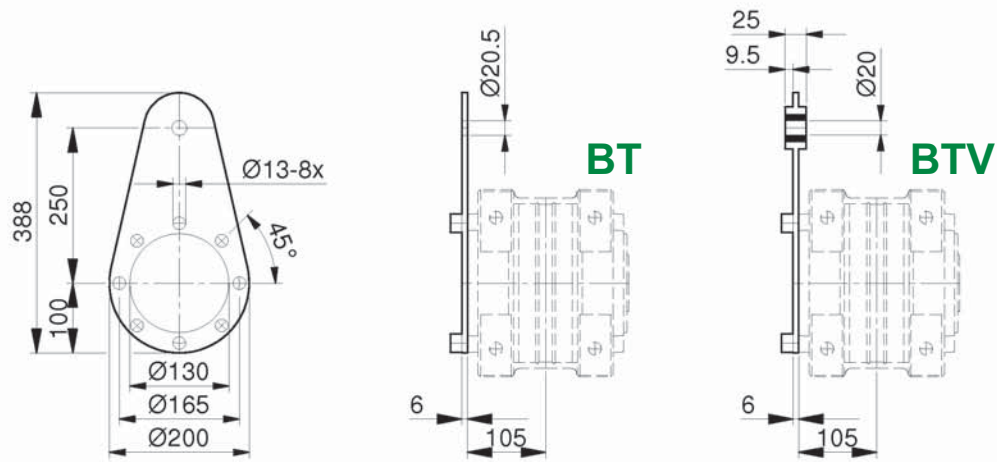

Dimensioni e pesi non impegnativi

Not binding dimensions and weights

unverbindliche Abmessungen u. Gewichte

**MRN  
FRN**

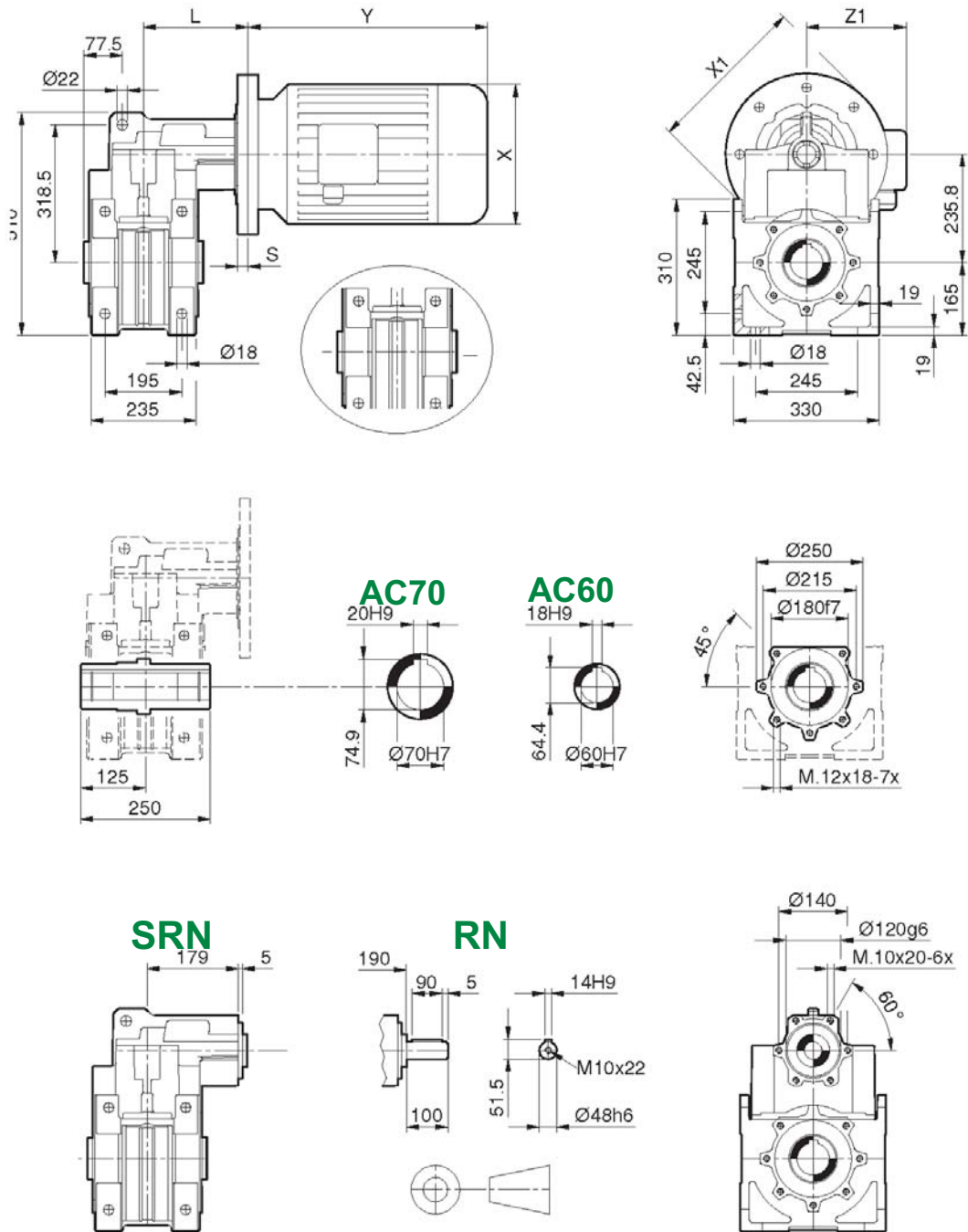

RN	62 / 63	62 / 63	62 / 63	62 / 63	62 / 63	62 / 63	62
IEC	80	90 S / L	100	112	132 S / M	160	180
X / Y / Z1	159/238/138	176/255-280/149	195/314/160	219/328/172	258/368-410/192	310/486/235	320/580/245
X1 (B5) / S	200/22	200/22	250/22	250/22	300/22	350/35	350/35
X1 (B14) / S	---	---	---	---	200/22	250/22	300/22
L (RN62)	201	201	201	201	201	214 (201)	214 (201)
L (RN63)	201	201	201	201	201	214 (201)	---

Dimensioni e pesi non impegnativi

Not binding dimensions and weights

unverbindliche Abmessungen u. Gewichte

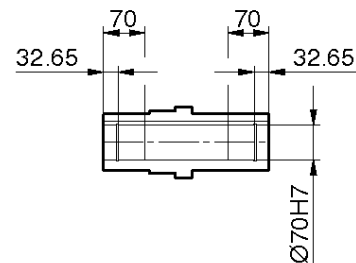
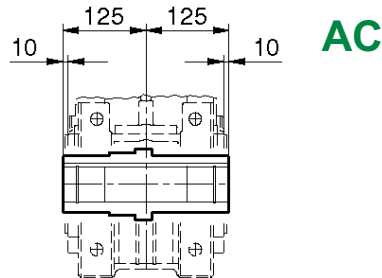

**AS**

**AD**

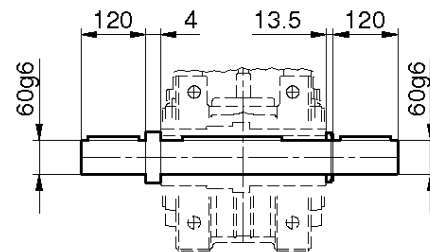
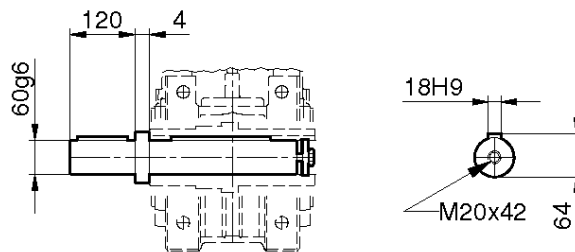

**ACC**

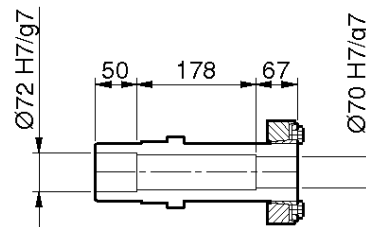
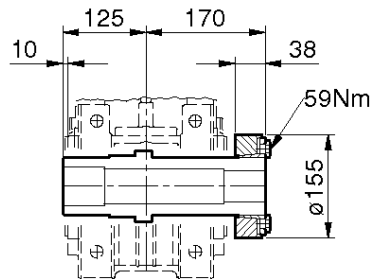

**ACS**

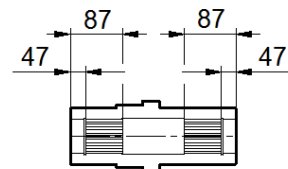
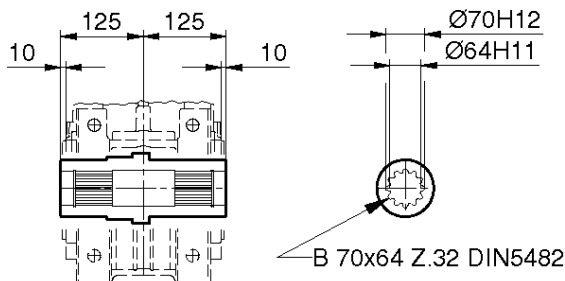

- Dimensioni del perno macchina: pagine
- Machine shaft dimensions: pages 80-82
- Maschinenwelle Abmessungen: Seiten



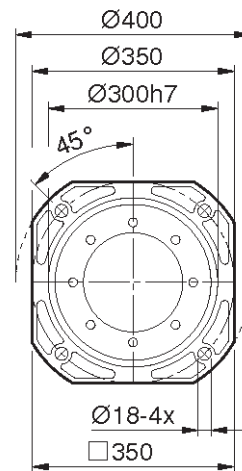
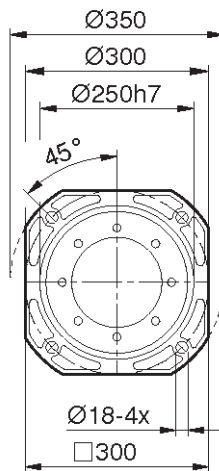
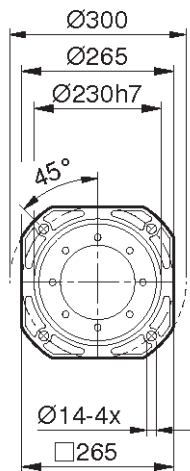
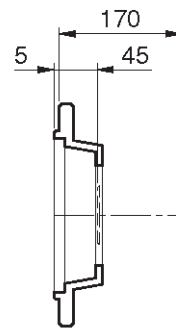
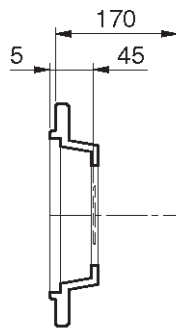
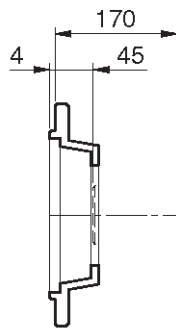
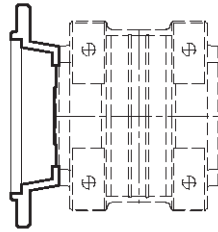

# RN62-63

# Getriebe - Gearboxes - Riduttori RN

Abmessungen - Dimensions - Dimensioni

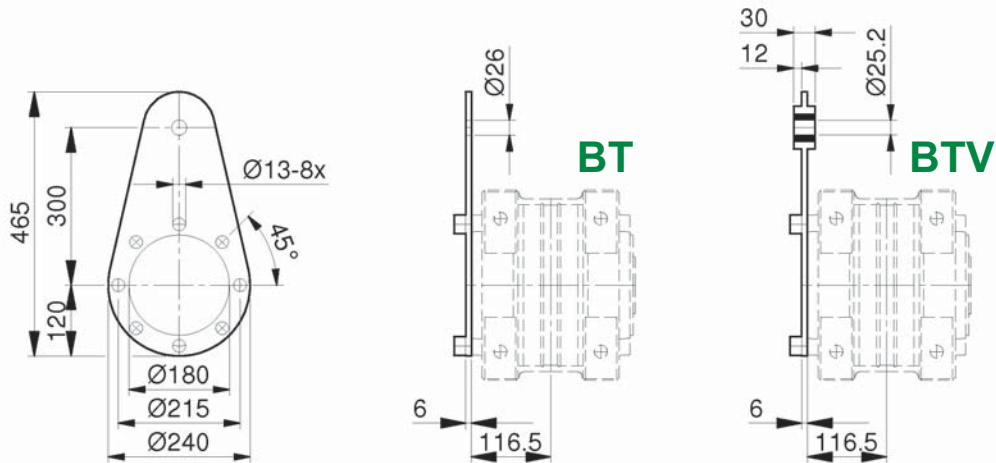

## BTA

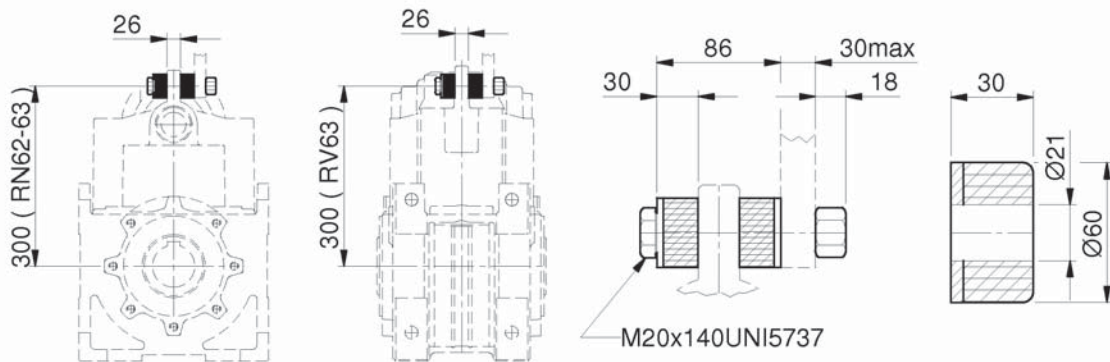

## BTF

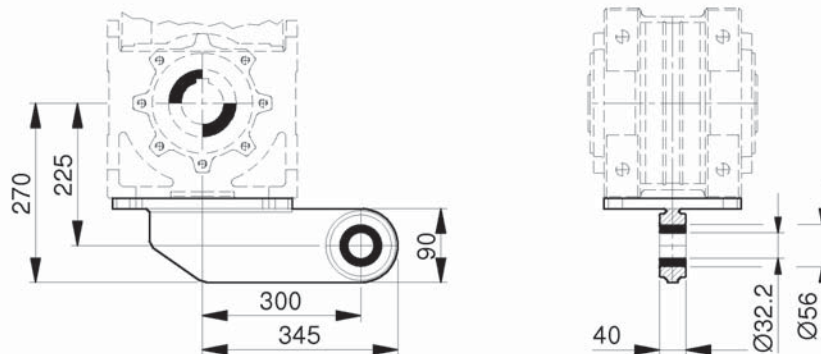

Dimensioni e pesi non impegnativi

Not binding dimensions and weights

unverbindliche Abmessungen u. Gewichte

## RN Riduttori - Gearboxes - Getriebe

### Dimensioni Albero Macchina - Machine Shaft Dimensions - Maschinenwelle Abmessungen

La tabella fornisce le dimensioni dell'albero macchina adatto ad inserirsi nell'albero cavo di uscita AC con chiavetta standard.

The table provides the dimensions of the machine shaft to be inserted into the AC hollow output shaft with standard key.

Die Tabelle gibt die Abmessungen der Maschinenwelle an, geeignet zur Einsetzung der Ausgangskeilhohlwelle AC mit externer Schrumpfscheibe.

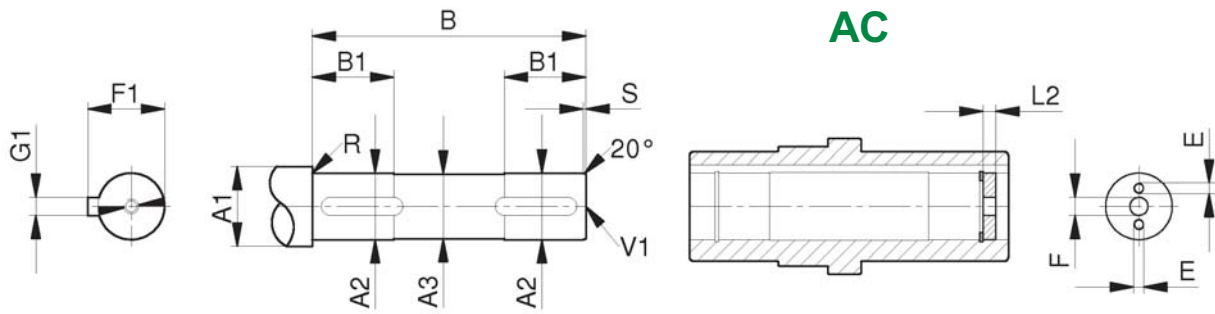

- Montaggio  
Mounting  
Montage

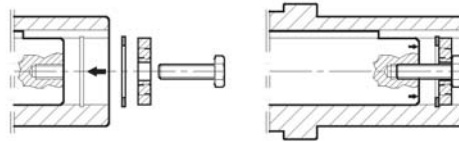

- Smontaggio  
Disassembly  
Demontage

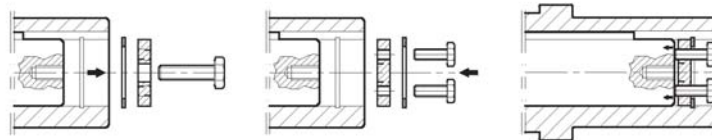

Size	A1	A2	A3	B	B1	E	F	F1	G1	L2	R	S	V1
RN12 - RN13	40	<b>30</b>	29	98	35	M6	11	33	8	5,5	1	2	M10x22
	35	<b>25</b>	24	98	35	M6	9	28	8	4,5	1	2	M8x19
RN22 - RN23	45	<b>35</b>	34	113,5	40	M8	11	38	10	7	1	2	M10x22
	40	<b>30</b>	29	113,5	40	M6	11	33	8	7	1	2	M10x22
RN32 - RN33	50	<b>40</b>	39	133,5	45	M8	13	43	12	7	1	2	M12x28
	45	<b>35</b>	34	133,5	45	M8	11	38	10	7	1	2	M10x22
RN42 - RN43	60	<b>50</b>	49	155,5	55	M10	17	53,5	14	8	1,5	3	M16x36
	55	<b>45</b>	44	155,5	55	M10	17	48,5	14	8	1,5	3	M16x36
	50	<b>40</b>	39	155,5	55	M8	13	43	12	8	1,5	3	M12x28
RN52 - RN53	75	<b>60</b>	59	185	65	M12	17	64	18	12,5	2	4	M16x36
	70	<b>55</b>	54	185	65	M12	17	59	16	12,5	2	4	M16x36
	65	<b>50</b>	49	185	65	M10	17	53,5	14	12,5	2	4	M16x36
RN62 - RN63	85	<b>70</b>	69	205	70	M12	21	74,5	20	12,5	2	4	M20x42
	80	<b>65</b>	64	205	70	M12	21	69	18	12,5	2	4	M20x42
	75	<b>60</b>	59	205	70	M12	21	64	18	12,5	2	4	M16x36

Dimensioni e pesi non impegnativi

Not binding dimensions and weights

unverbindliche Abmessungen u. Gewichte

# Getriebe - Gearboxes - Riduttori RN

## Maschinenwelle Abmessungen - Machine Shaft Dimensions - Dimensioni Albero Macchina

La tabella fornisce le dimensioni dell'albero macchina adatto ad inserirsi nell'albero cavo di uscita ACC con calettatore esterno.

The table provides the dimensions of the machine shaft to be inserted into the ACC hollow output shaft with shrink disk.

Die Tabelle gibt die Abmessungen der Maschinenwelle an, geeignet zur Einsetzung der Ausgangskeilhohlwelle ACC mit externer Schrumpfscheibe.

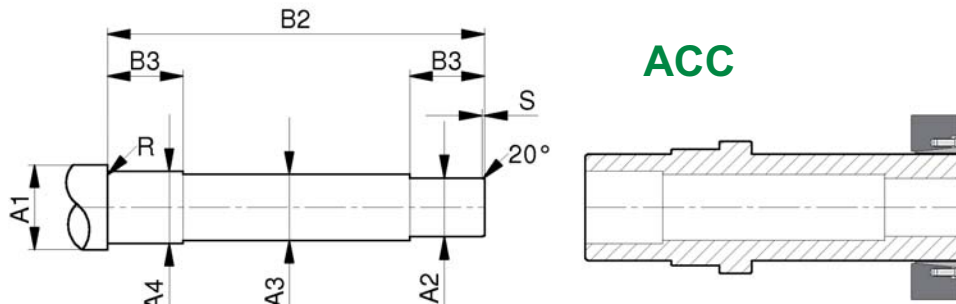

Size	A1	A2	A3	A4	B2	B3	R	S
RN12 - RN13	40	<b>30</b>	29	32	144	34	1	2
RN22 - RN23	45	<b>35</b>	34	37	167	39	1	2
RN32 - RN33	50	<b>40</b>	39	42	189	49	1	2
RN42 - RN43	60	<b>50</b>	49	52	220	49	1,5	3
RN52 - RN53	75	<b>60</b>	59	62	267	49	2	4
RN62 - RN63	85	<b>70</b>	69	72	294	49	2	4

Il calettatore è basato sullo sperimentato principio del cuneo per creare un accoppiamento meccanico per interferenza senza chiave.

Il serraggio assiale delle viti è convertito in pressione di contatto radiale fra albero e mozzo, causandone lo stabile calettamento.

### Montaggio

Pulire accuratamente le superfici di contatto dell'albero e del mozzo e applicare un leggero velo d'olio. Serrare le viti in modo graduale ed uniforme fino a raggiungere la coppia di serraggio. Non usare oli contenenti bisolfuro di molibdeno che originano notevoli riduzione del coefficiente d'attrito. Durante il serraggio delle viti non avviene nessun spostamento assiale del mozzo rispetto all'albero.

### Smontaggio

Allentare le viti con sequenza continua e graduale senza estrarre le viti dalle filettature.

In caso di riutilizzo, applicare alle viti e superfici coniche un lubrificante in pasta per garantire un coefficiente d'attrito di 0.04. Coppie di serraggio, tolleranze e rugosità secondo le specifiche del costruttore.

The shrink-disk fit relies upon the proven wedge principle to create a keyless mechanical interference fit.

Screw axial locking tension is converted into radial contact pressure on the shaft/hub connection, making the shrink fit steady.

### Assembly

Carefully clean the shaft/hub contact surfaces and grease with a fine layer of oil. Tighten the screws gradually and evenly until the locking torque is reached.

Do not use lubricants containing molybdenum bisulphate that origins notable lowering of the friction coefficient. No axial hub shifting occurs as regards the shaft when are tightening the screws.

### Disassembly

Loose the screws in a continuous and even way without removing the screws.

In case of further assembly, apply a lubricant paste on screws and tapered surfaces to guarantee a friction coefficient of 0.04.

Locking torques, tolerances and roughness according to manufacturer's specifications.

Die Schrumpfscheibe liegt dem versuchten Prinzip des Keiles zugrunde, um eine mechanische Kupplung zur Interferenz ohne Keilnut zu kreieren. Das axiale Anziehen der Schrauben wurde in radialem Anpressdruck zwischen Welle und Nabe umgesetzt, verursacht Stabilität der Schrumpfscheibe.

### Montage

Sorgfältig die Kontaktflächen der Welle und der Nabe reinigen und ein wenig Öl aufbringen. Die Schrauben gradual und einheitlich anziehen bis zur Erzielung des Anzugsdrehmoment. Verwenden Sie keine Öle mit Molybdänsulfid, wegen erheblicher Reduzierung des Reibungskoeffizienten. Während des Anziehens der Schrauben erfolgt keine axiale Verschiebung der Nabe gegenüber der Welle.

### Demontage

Lösen Sie die Schrauben kontinuierlich und schrittweise, ohne die Schrauben aus dem Gewinde zu entfernen. Im Falle der Wiederverwendung, tragen Sie auf den Schrauben und Kegelflächen eine Schmierpaste, um ein Reibungskoeffizient von 0,04 zu garantieren. Drehmomente, Toleranzen und Rauigkeit nach Angaben des Herstellers.

Dimensioni e pesi non impegnativi

Not binding dimensions and weights

unverbindliche Abmessungen u. Gewichte

# RN Riduttori - Gearboxes - Getriebe

## Maschinenwelle Abmessungen - Machine Shaft Dimensions - Dimensioni Albero Macchina

La tabella fornisce le dimensioni dell'albero macchina adatto ad inserirsi nell'albero cavo di uscita scanalato ACS.

The table provides the dimensions of the machine shaft to be inserted into the ACS splined hollow output shaft.

Die Tabelle gibt die Abmessungen der Maschinenwelle an, geeignet zur Einsetzung der Ausgangskeilhohlwelle ACS mit externer Schrumpfscheibe.

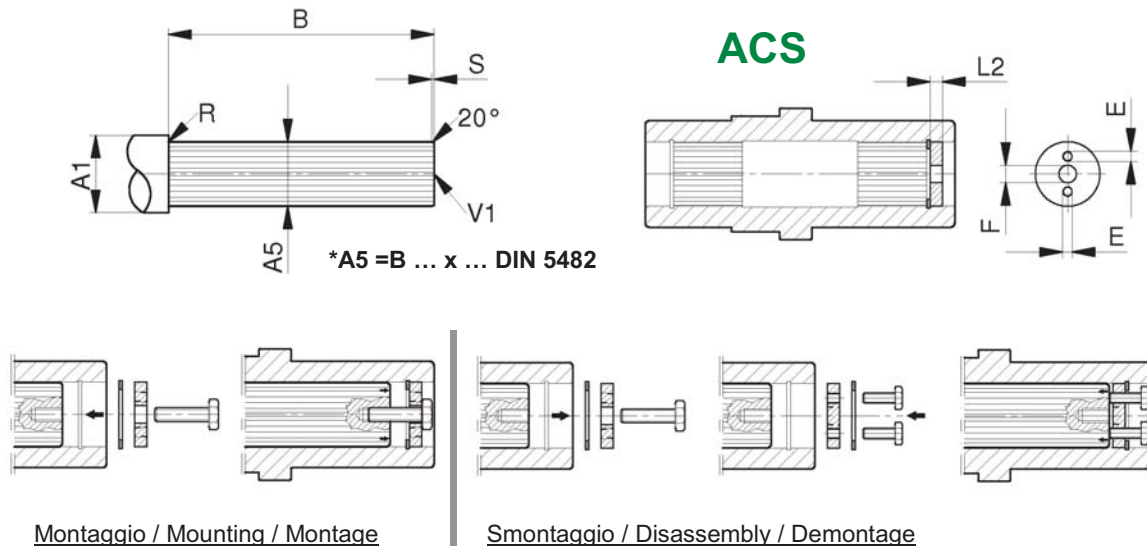

Size	A1	A2	A3	A4	A5	B	B2	B3	E	F	L2	R	S	V1
RN12 - RN13	40	<b>30</b>	29	32	30x27	98	144	34	M6	11	5,5	1	2	M8x19
RN22 - RN23	45	<b>35</b>	34	37	35x31	113,5	167	39	M8	11	7	1	2	M10x22
RN32 - RN33	50	<b>40</b>	39	42	40x36	133,5	189	49	M8	13	7	1	2	M10x22
RN42 - RN43	60	<b>50</b>	49	52	50x45	155,5	220	49	M10	17	8	1,5	3	M16x36
RN52 - RN53	75	<b>60</b>	59	62	60x55	185	267	49	M12	17	12,5	2	4	M16x36
RN62 - RN63	85	<b>70</b>	69	72	70x64	205	294	49	M12	21	12,5	2	4	M20x42

Gli alberi scanalati hanno denti che ingranano con corrispondenti scanalature di un pezzo accoppiante e gli trasferiscono la coppia mantenendo la corrispondenza angolare fra loro. Alternativi al collegamento cava/chiavetta, gli scanalati forniscono maggior coppia e maggior durata alla fatica.

Spline shafts have teeth that mesh with grooves in a mating piece and transfer torque to it, maintaining the angular correspondence between them. As alternative to key/keyway connection, splines provide higher torque and longer fatigue lifetime.

Die Keilwellen haben Zähne mit entsprechenden Nuten eines Kupplungsstückes und übertragen das Drehmoment mit Einhaltung des Winkels zwischen Ihnen. Alternativ zur Verbindung von Schlüssel/Keilnut, die Keilwellen bieten mehr Drehmoment und höhere Lebensdauer an.

Dimensioni e pesi non impegnativi

Not binding dimensions and weights

unverbindliche Abmessungen u. Gewichte

# Getriebe - Gearboxes - Riduttori RN

## Zubehörlage - Accessory position - Posizione accessori

Le posizioni degli accessori, nelle definizioni RH e LH, fanno riferimento alla posizione di montaggio H1 a pag. 14 e sono viste dal lato inferiore del riduttore RN2 o RN3.

Il lato della carcassa con la vite come indicata è la esatta identificazione del lato di riferimento.

Se l'accessorio viene richiesto montato in fabbrica, l'ordine è considerato in sospenso fino alla determinazione del lato RH o LH.

Per altre posizioni di montaggio, riferirsi al Servizio Clienti.

Accessory positions, here defined as RH and LH, refer to H1 mounting position at page 14 and are seen from the bottom side of the gearbox RN2 or RN3 accordingly.

The housing side with the screw as shown is the right identification of the reference side.

If the accessory is requested in-house assembled, the order is held-on until RH or LH side is defined.

For other mounting positions, please refer to the Customer Service.

Die Zubehörpositionen, hier als RH und LH definiert, beziehen sich auf H1 Einbaulage auf Seite 14 und werden von der Unterseite des Getriebes RN oder RN3 entsprechend gesehen. Die Seite des Gehäuses mit der Schraube, wie gezeigt ist die genaue Identifizierung der Referenzseite.

Wenn das Zubehör am haus angeforderte gebaut wird die Reihenfolge gehalten, bis Seite RH oder LH definiert ist.

Für andere Einbaulagen entnehmen Sie bitte dem Kundendienst beziehen.

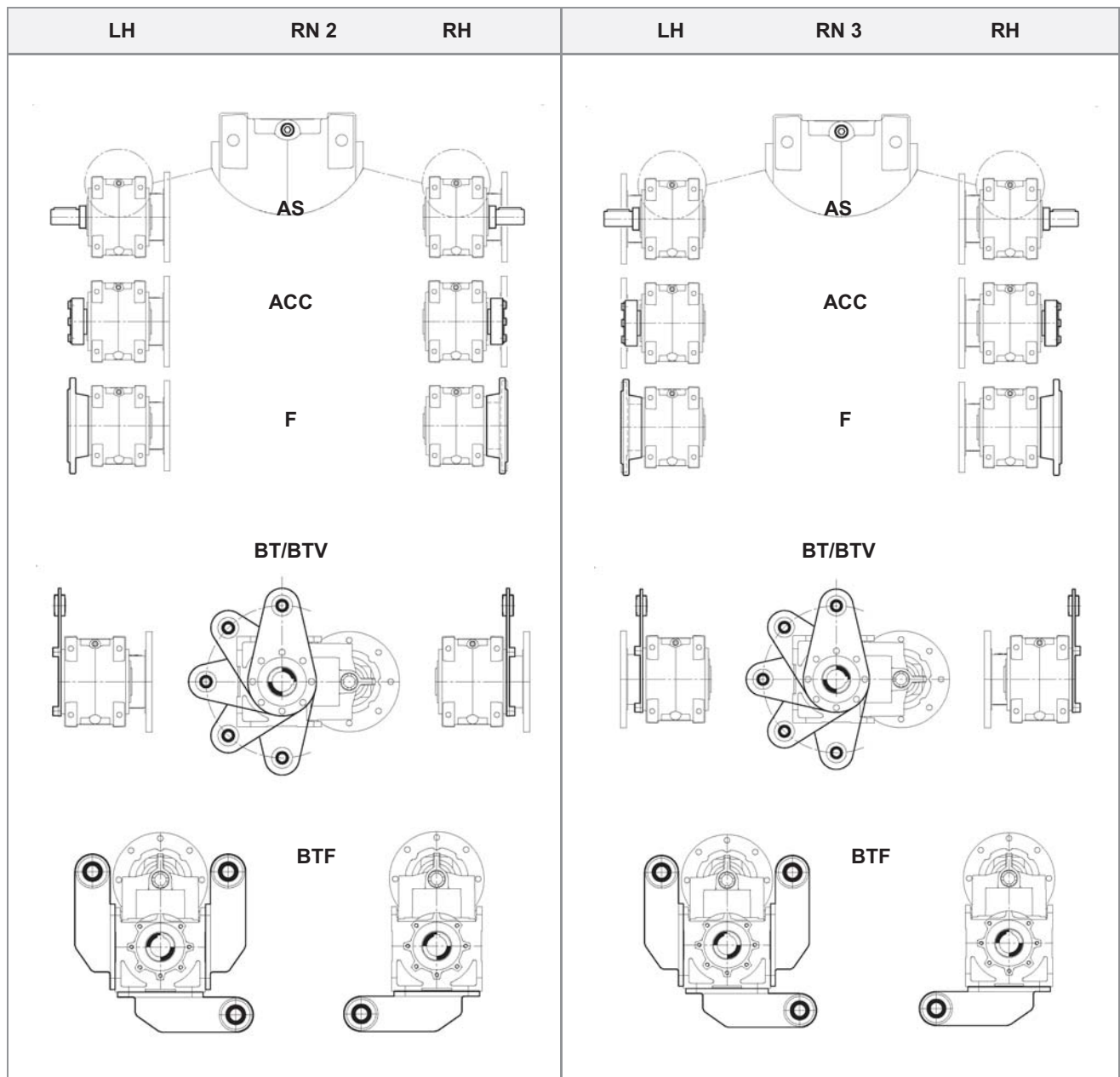



## RN Riduttori - Gearboxes - Getriebe

Rotazione e Parti Componenti - Rotation and Component Parts - Drehrichtung u. Bauelemente

### RN2

#### Riduttore a due coppie Two-stage gearbox Zweistufige Getriebe

- A - Flangia motore IEC  
IEC motor flange  
Motorflansch IEC
- B - Coperchio entrata 2 coppie & pignone T3  
2 stage input cover + T3 gear  
Zweistufige Eingangsdeckel u. Ritzel T3
- C - Carcassa & ingranaggi T4, T5, T6  
Housing + T4, T5, T6 gears  
Gehäuse u. Räder T4, T5, T6
- D - Flangia di uscita  
Output flange  
Abtriebsflansch



- Rotazione entrata/uscita  
- Input/output rotation  
- Eingangs- / Ausgangsdrehrichtung

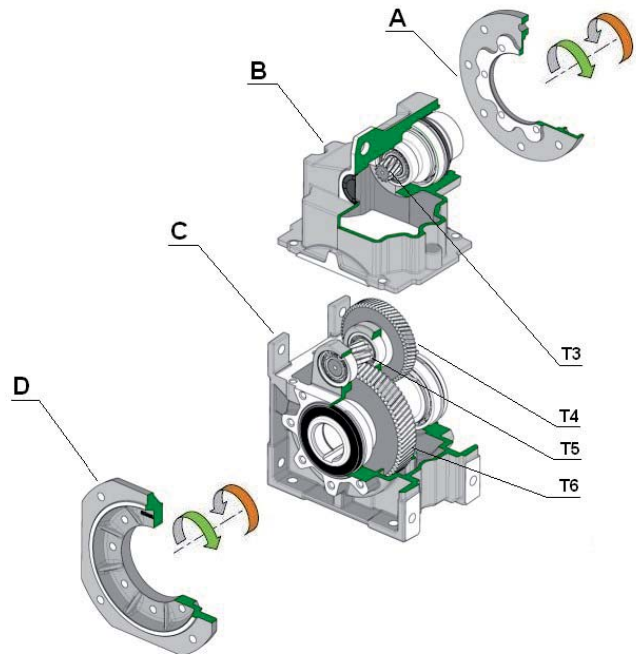

### RN3

#### Riduttore a tre coppie Three-stage gearbox Dreistufige Getriebe

- A - Flangia motore IEC  
IEC motor flange  
Motorflansch IEC
- B - Coperchio entrata 3 coppie & ingranaggi T1, T2, T3  
3 stage input cover + T1, T2, T3 gears  
Dreistufige Eingangsdeckel u. Räder T1, T2, T3
- C - Carcassa & ingranaggi T4, T5, T6  
Housing + T4, T5, T6 gears  
Gehäuse u. Räder T4, T5, T6
- D - Flangia uscita  
Output flange  
Abtriebsflansch



- Rotazione entrata/uscita  
- Input/output rotation  
- Eingangs-/Ausgangsdrehrichtung

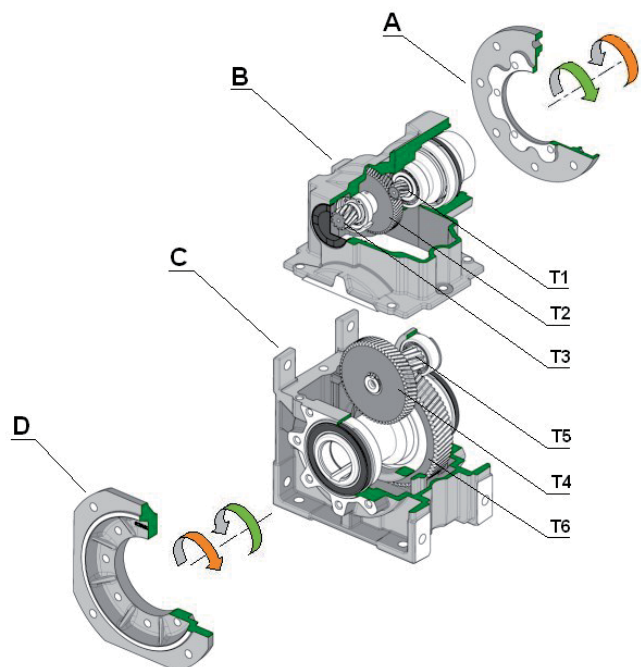

# Getriebe - Gearboxes - Riduttori RN

Standard Motori elettrici - Electric motor Standards - E-Motoren Standards

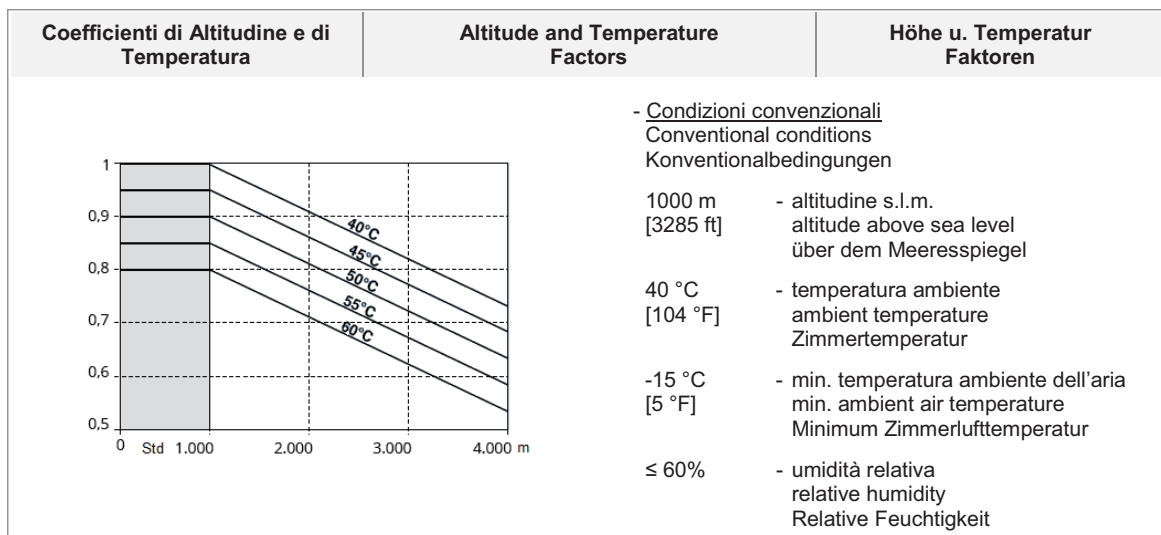
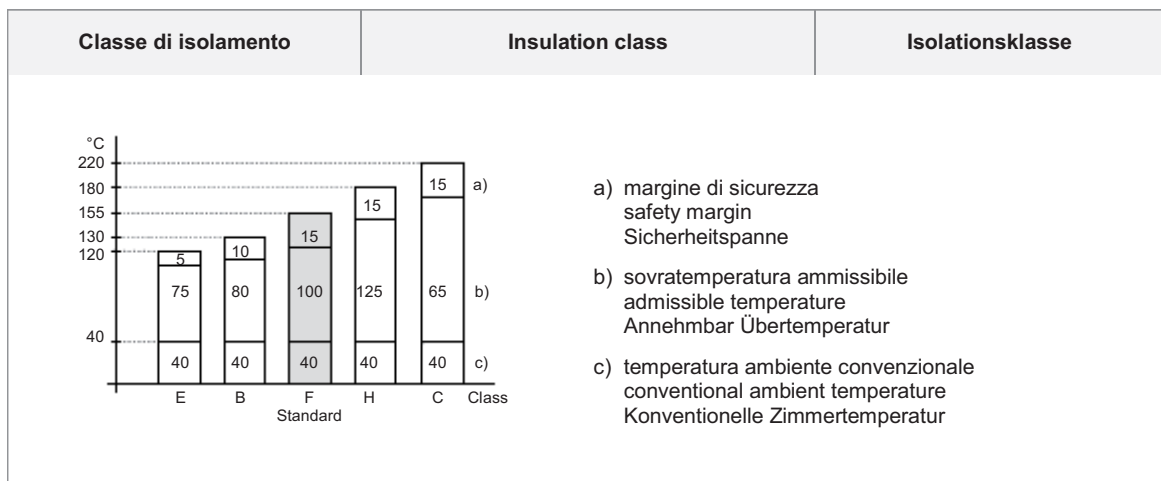
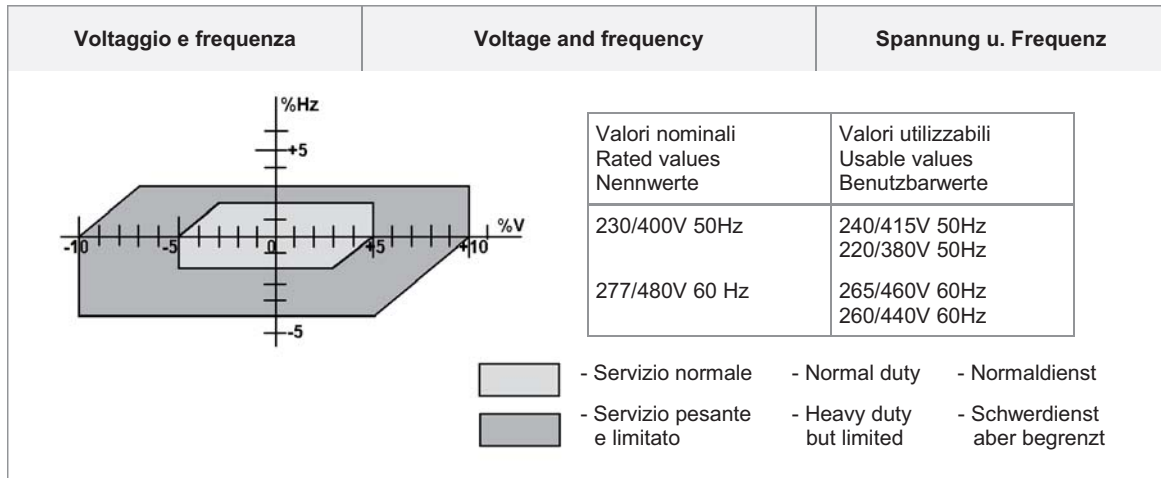

## RN Riduttori - Gearboxes - Getriebe

ATEX - Direttiva Europea 94/9/CE - European Directive 94/9/EC - Europäische Richtlinie 94/9/EU

La Direttiva Europea 94/9/CE-ATEX riguarda non solo gli apparecchi elettrici ma tutte le macchine e gli organi di comando che sono destinati, soli o combinati, ad essere utilizzati in atmosfere potenzialmente esplosive nei territori della Comunità Europea.

I riduttori VARVEL-ATEX sono costruiti con

- carcassa e coperchi in materiale metallico, contenenti gli elementi di trasmissione montati su cuscinetti a sfere o a rulli;
- paraolio in Viton sugli alberi di entrata e di uscita;
- quantità di lubrificante idonea per assicurare il funzionamento del progetto;
- viteria sigillata con pasta frena-filetti.

I riduttori VARVEL-ATEX sono identificati nella Direttiva come «componenti», pertanto privati di loro funzione autonoma, ma essenziali per il funzionamento di apparecchi e di sistemi di protezione destinati alla produzione, trasporto, immagazzinamento, misurazione, regolazione e conversione d'energia e trasformazione dei materiali che, per le loro proprie potenzialità d'infiammabilità, rischiano di provocare l'insacco di un'esplosione.

### Terminologia Direttiva ATEX:

- **Gruppo**  
Gruppo I - utilizzazione in miniera  
Gruppo II - utilizzazione in industrie di superficie
- **Categoria**  
Categoria 1 - esposizione continuata in ambiente possibilmente esplosivo con durata > 1000 ore/anno o con frequenti malfunzionamenti  
Categoria 2 - esposizione occasionale in ambiente possibilmente esplosivo con durata fra 10 e 1000 ore/anno o con saltuari malfunzionamenti  
Categoria 3 - esposizione poco probabile in ambiente possibilmente esplosivo e se avvenuta, si verifica per un breve periodo con durata inferiore a 10 ore/anno
- **Lettere "G" e "D"**  
Presenza di gas (G) e di polveri (D)
- **Lettere "c" e "k"**  
Indici di sicurezza di costruzione (c) e di immersione in liquido (k).
- **IP66**  
Grado di protezione
- **T<sub>max</sub> e T<sub>amb</sub>**  
Temperature massima di superficiale (T<sub>max</sub>) e d'ambiente (T<sub>amb</sub>).

The European Directive 94/9/EC-ATEX relates not only to electric devices but to all the machines and driving units destined, alone or combined, to operate in potentially explosive environments within European Community territory.

The gearboxes VARVEL-ATEX are manufactured

- with metallic housings and covers, containing the driving gears fitted on ball or roller bearings;
- Viton oil seals on input and output shafts;
- the needed oil quantity to ensure the unit operation;
- sealed thread screws with sealing paste.

The gearboxes VARVEL-ATEX are identified in the Directive as «components», therefore stripped away any autonomous function, but fundamental to operation of units and protection systems destined to production, transport, storage, measuring, adjusting and conversion of energy and material transformation that because of their own inflammable potentiality, risk to induce an explosion trigger.

### Directive-ATEX terminology:

- **Group**  
Group I - use in mine  
Group II - use in surface industries
- **Category**  
Category 1 - continuous exposure in possibly explosive environment for more than 1000 hrs/year or with frequent malfunctioning  
Category 2 - occasional exposure in possibly explosive environment for 10 to 1000 hrs/year or with sporadic malfunctioning  
Category 3 - not very likely exposure in possibly explosive environment and if happened, not longer than 10 hours/year
- **Letters "G" and "D"**  
Gas (G) or dust (D) presence
- **Letters "c" and "k"**  
Safety indication of construction (c) and immersion in liquid (k)
- **IP66**  
Protection grade
- **T<sub>max</sub> and T<sub>amb</sub>**  
Surface (T<sub>max</sub>) and Ambient (T<sub>amb</sub>) max. temperature

Die Europäische Richtlinie 94/9/EG-ATEX gilt nicht für elektrische Ausrüstungen, sondern auch für alle Arten von Maschinen und Steuerungsteile, allein oder kombiniert, für den Gebrauch in potentiell explosiver Atmosphäre in den Gebieten der Europäischen Gemeinschaft.

Die VARVEL-ATEX Getriebe sind hergestellt mit

- Gehäuse und Deckel in Metall, beinhaltet Getriebe montiert auf Kugel- oder Rollenlager;
- Viton-Dichtungen auf Eingangs- und Ausgangswellen;
- ausreichende Ölmenge, um das Funktionieren des Projekts zu gewährleisten;
- Schrauben sind mit Schraubensicherungspaste abgedichtet.

VARVEL-ATEX Getriebe sind in der Richtlinie als "Komponenten" identifiziert, von daher ihre autonome Funktion, aber wesentlich für den Betrieb von Geräten und Schutzsystemen für die Produktion, Transport, Lagerung, Messung, Regelung und Umwandlung von Energie und Verarbeitung von Materialien, die wegen ihrer eigenen potenzieller Entflammbarkeit, die Auslösung einer Explosion riskieren.

### Terminologie ATEX Richtlinie



- **Gruppe**  
Gruppe I - Verwendung in Minen  
Gruppe II - Verwendung in Oberflächen Branchen
- **Kategorien**  
Kategorie 1 - kontinuierliche Exposition in möglicher explosiver Umgebung bei Dauer > 1000 Stunden/Jahr oder mit häufigen Störungen  
Kategorie 2 - gelegentliche Exposition in möglicher explosiver Umgebung mit Dauer zwischen 10 und 1000 Stunden/Jahr o mit gelegentlichen Fehlfunktionen  
Kategorie 3 - unwahrscheinliche Exposition, in möglicher explosiver Umgebung und wenn dies eintritt, bei einem kurzen Zeitraum mit Dauer von weniger als 10 Stunden/Jahr
- **Buchstaben "G" und "D"**  
Vorhandensein von Gas (G) und Staub (D)
- **Buchstaben "c" und "k"**  
Indiz der Bausicherheit (c) und Eintauchen in Flüssigkeit (k).
- **IP66**  
Schutzgrad
- **T<sub>max</sub> e T<sub>amb</sub>**  
Maximale Oberflächentemperatur (T<sub>max</sub>) und Umgebungstemperatur (T<sub>amb</sub>).

## Getriebe - Gearboxes - Riduttori RN

ATEX - Direttiva Europea 94/9/CE - European Directive 94/9/EC - Europäische Richtlinie 94/9/EU



Le serie VARVEL RD, RS, RT, RN, RO, RV, RP90 e XA100 sono conformi alle richieste di progetto esatte dal Gruppo II, Categoria 2 o 3 e per funzionamento in zone con pericolo di esplosione in presenza di gas (zona 1 e zona 2) e di polveri combustibili (zona 21 e zona 22).

I prodotti VARVEL-ATEX sono marcati

 **II 2 GD ck IP66**   
T<sub>max</sub>=135°C

VARVEL RD, RS, RT, Rn, RO, RV, RP90 and XA100 series are conforming with design requirements asked by Group II, Category 2 or 3, and for operation in possible hazardous zones in presence of gas (zones 1 and 2) and combustible dust (zones 21 and 22).

The VARVEL-ATEX products are marked

 **II 2 GD ck IP66**   
T<sub>max</sub>=135°C

Die Serie VARVEL RD, RS, RT, RN, RO, RV, RP90 u. XA100 sind Übereinstimmung mit die Konstruktionsanforderungen gebeten von Gruppe II, Kategorie 2 oder 3 und für Betrieb in Zonen mit Explosionsgefahr in der Gegenwart von Gas (Zone 1 und Zone 2) und Staub (Zone 21 und Zone 22).

Die Produkte VARVEL-ATEX sind markiert

 **2 GD ck IP66**   
T<sub>max</sub>=135°C

Gruppo Group Gruppe	Categoria Category Kategorie	Gas, Vapori, Nebbie Gas, Vapours, Cloud Gas, Dämpfe, Nebel	Zona Zone	Polveri Dust Stäube
I (a)	M1 (c) M2 (d)			
II (b)	1 (c)	G (0)		D (20)
	2 (d)	G (1)		D (21)
	3 (e)	G (2)		D (22)

### Attenzione

I riduttori VARVEL-ATEX **non sono certificati** per funzionamento nelle aree in **colore grigio**.

- (a) - Miniere
- (b) - Industrie di superficie
- (c) - Livello di protezione: molto elevato
- (d) - Livello di protezione: elevato
- (e) - Livello di protezione: normale
- (0) - Presenza continua di gas
- (1) - Presenza discontinua di gas
- (2) - Presenza occasionale di gas
- (20) - Presenza continua di polveri
- (21) - Presenza discontinua di polveri
- (22) - Presenza occasionale di polveri

### Warning

The VARVEL-ATEX gearboxes **are not certified** for operation in **shaded areas**.

- (a) - Mines
- (b) - Surface industries
- (c) - Protection level: very high
- (d) - Protection level: high
- (e) - Protection level: normal
- (0) - Continuous presence of gas
- (1) - Discontinuous presence of gas
- (2) - Occasional presence of gas
- (20) - Continuous presence of dust
- (21) - Discontinuous presence of dust
- (22) - Occasional presence of dust

### Vorsicht !

Die Getriebe VARVEL-ATEX sind für den Anbau in die **Graufarbezone nicht zertifiziert**.

- (a) - Bergwerke
- (b) - Oberfläche-Industrien
- (c) - Schutzklasse: sehr hoch
- (d) - Schutzklasse: hoch
- (e) - Schutzklasse: normal
- (0) - ständige Gegenwart von gas
- (1) - nicht ständige Gegenwart von gas
- (2) - gelegentliche Gegenwart von gas
- (20) - ständige Gegenwart von Stäube
- (21) - nicht ständige Gegenwart von Stäube
- (22) - gelegentliche Gegenwart von Stäube

# RN Riduttori - Gearboxes - Getriebe

**Estratto delle ISTRUZIONI D'USO E MANUTENZIONE**  
(manuale completo su [www.varvel.com](http://www.varvel.com))

I riduttori e i variatori di velocità non ricadono nel campo d'applicazione della Direttiva Macchine, art.1(2) e non possono essere messi in servizio finché la macchina nella quale devono essere incorporati, sia stata dichiarata conforme all'art. 4(2), all. II(B) delle Direttive Macchine 98/37/CEE/22,6,98 e, solo per l'Italia, al DL 459/24,7,96.

### Installazione

Accertarsi che il gruppo da installare abbia le caratteristiche atte a svolgere la funzione richiesta e che la posizione di montaggio sia coerente con quanto ordinato. Tali caratteristiche sono deducibili dalla targhetta d'identificazione apposta sul riduttore. Effettuare la verifica della stabilità del montaggio affinché non si verificino vibrazioni o sovraccarichi durante il funzionamento.

### Funzionamento

Il riduttore può essere collegato per rotazione oraria o antioraria. Arrestare immediatamente il riduttore in caso di funzionamento difettoso o di rumorosità anomala, rimuovere il difetto o ritornare l'apparecchio alla fabbrica per un'adeguata revisione. Se la parte difettosa non è sostituita, anche altri componenti possono essere danneggiati con conseguenti ulteriori danneggiamenti e più scarsa possibilità di risalire alle cause.

### Manutenzione

Sebbene i gruppi siano provati con funzionamento senza carico prima della spedizione, è consigliabile non usarli a carico massimo durante le prime 20-30 ore di funzionamento affinché le parti interne possano adattarsi reciprocamente. I riduttori sono spediti già riempiti con olio sintetico a lunga durata e, se occorre sostituire o rabboccare il lubrificante, non mescolare oli a base sintetica con oli a base minerale.

### Movimentazione

In caso di sollevamenti con paranco, utilizzare posizioni di aggancio sulla struttura della carcassa, golfari ove esistenti, fori dei piedi o sulle flange, evitando tutte le parti mobili.

### Verniciatura

Qualora il gruppo subisca una verniciatura successiva, è necessario proteggere accuratamente gli anelli di tenuta, i piani di accoppiamento e gli alberi sporgenti.

### Conservazione prolungata a magazzino

Per permanenze maggiori di tre mesi, è consigliata l'applicazione di antiossidanti su alberi esterni e piani lavorati, e di grasso protettivo sui labbri dei paraolio.

### Gestione Ambientale del prodotto

In conformità alla Certificazione Ambientale ISO 14001, sono suggerite le seguenti indicazioni per lo smaltimento del nostro prodotto:

- i componenti del gruppo che vengono rottamati debbono essere consegnati a centri di raccolta autorizzati per i materiali metallici;
- gli oli ed i lubrificanti raccolti dal gruppo devono essere smaltiti consegnandoli ai Consorzi Oli esausti;
- gli imballi a corredo dei gruppi (pallet, cartone, carta, plastica, ecc.) vanno avviati per quanto più possibile al recupero/riciclo, consegnandoli a ditte autorizzate per le singole classi di rifiuto.

**Abstract of OPERATION AND MAINTENANCE INSTRUCTIONS**  
(complete manual on [www.varvel.com](http://www.varvel.com))

Variable speed and reduction gearboxes are not part of the field of application of the Machinery Directive, art.1(2), and they must not be put into service until the machinery into which they are to be incorporated, has been declared in conformity with the provision of art.4(2), annex II(B) of Machinery Directives 98/37/CEE/22,6,98 and for Italy only, of DL 459/24,7,96.

### Installation

Check if the unit to be installed, is properly selected to perform the required function and that its mounting position complies with the order. The nameplate reports such information. Check mounting stability to ensure the unit runs without vibrations or overloads.

### Running

The unit may be connected for clockwise or counter-clockwise rotation.

The unit must be stopped as soon as defective running or unexpected noise occur, remove the faulty part or return the unit to the factory for checking.

If the faulty part is not replaced, other parts can also be affected, causing more severe damage and making the identification of initial cause more difficult.

### Maintenance

Although the units are no-load run tested in the factory before despatch, it is recommended not to run them at maximum load for the first 20-30 running hours to allow the proper running in.

The gearboxes are delivered already filled with long-life synthetic oil and, in case of replacement or topping, do not mix with mineral lubricants.

### Handling

When hoisting, use relevant housing locations or eyebolts if provided, or foot or flange holes. Never hoist on any moving part.

### Painting

Carefully protect oil seals, coupling faces and shafts when units are re-painted.

### Long-term storage

For storages longer than three months, apply anti-oxidants onto shafts and machined surfaces, and protective grease on oil seal lips.

### Product's Environmental Management

In conformity with Environmental Certification ISO 14001, we recommend the following to dispose of our products:

- scraped components of the units to be delivered to authorized centres for metal object collection;
- oils and lubricants drained from the units to be delivered to Exhausted Oil Unions;
- packages (pallets, carton boxes, paper, plastic, etc.) to lead into regeneration/recycling circuits as far as possible, by delivering separate waste classes to authorized companies.

**Zusammenfassung der BETRIEBS- u. WARTUNGSANWEISUNGEN**  
(vollständiges Handbuch auf [www.varvel.com](http://www.varvel.com))

VARVEL-Getriebe und Variatoren fallen nicht unter den Geltungsbereich der Maschinenrichtlinien, Artikel 1 (2): Sie dürfen jedoch nicht in Betrieb gesetzt werden, bevor sich nicht Maschinen, in die sie eingebaut werden, mit Artikel 4 (2), Anhang II (B) der Maschinenrichtlinien 98/37/CEE/22,6,98, und (nur für Italien) DL 459/24,07,96, in Übereinstimmung befinden.

### Aufstellung

Vor der Aufstellung ist zu prüfen, dass die Antriebseinheit in Bezug auf die Betriebsbedingungen richtig ausgewählt wurde und die Einbaulage mit der Bestellung übereinstimmt. Angaben hierüber sind auf dem Typenschild zu finden. Die Stützkonstruktion für die Getriebe ist so stabil auszuführen, dass keine Schwingungen oder Überlastungen auftreten, eventuell sind elastische Kupplungen oder Drehmomentbegrenzer zu verwenden.

### Inbetriebnahme

Die Antriebseinheit kann in beiden Drehrichtungen eingesetzt werden. Die Einheit muss sofort angehalten werden, wenn ein unzulässiger Lauf oder unerwartete Geräusche auftreten.

Das fehlerhafte Teil ist zu ersetzen oder die Einheit ist zur Überprüfung einzuschicken, Falls das fehlerhafte Teil nicht ersetzt wird, kann dies zu weiteren Schäden an anderen Bauteilen führen, was eine Feststellung der Ursachen sehr schwierig machen kann.

### Wartung

Obwohl die Einheiten vor der Auslieferung im Leerlauf getestet wurden, ist es ratsam sie in den ersten 20-30 Stunden nicht mit Vollast zu betreiben, um ein einwandfreies Einlaufen zu gewährleisten. Die Einheiten werden entsprechend den Angaben auf dem Typenschild mit synthetischem Schmierstoff Lebensdauer geschmiert ausgeliefert. Bei einem eventuellen Ölwechsel oder Nachfüllen darf der Schmierstoff nicht mit Mineralöl vermischt werden.

### Handhabung und Transport

Beim Heben und Transport ist auf standsichere Lage und sorgfältige Befestigung geeigneter Hebe Vorrichtungen zu achten, Bewegliche Teile dürfen nicht zum Anheben benutzt werden.

### Anstrich

Beim Erneuern oder dem zusätzlichen Aufbringen eines Anstriches sind die Dichtungen, Kupplungssitze und Wellen sorgfältig zu schützen.

### Langzeitlagerung

Die Einlagerung der Einheiten muss trocken und staubfrei erfolgen. Bei einer Einlagerungszeit über 3 Monate sind bearbeitete Flächen und Wellen mit Rostschutzmitteln zu besprühen, Dichtlippen sind mit Fett zu schützen.

### Entsorgung

In Übereinstimmung mit ISO 14001 weisen wir darauf hin, im Falle des Verschrottens die einzelnen Metallteile getrennt zu behandeln und Schmiermittel bei den befüllten Stellen zu entsorgen. Verpackungen sollten soweit wie möglich wieder verwendet werden.



ARGENTINA  
AUSTRALIA  
AUSTRIA  
BELARUS  
BELGIUM  
BRAZIL  
BULGARIA  
CANADA  
CHILE  
CHINA  
COLOMBIA  
COSTA RICA  
CROATIA  
CYPRUS  
CZECH REPUBLIC  
DENMARK  
ECUADOR  
EGYPT  
ESTONIA  
FINLAND  
FRANCE  
GERMANY  
GREECE  
HOLLAND  
HONG KONG  
HUNGARY  
ICELAND  
**INDIA • Branch**  
INDONESIA  
IRAN  
IRELAND  
ISRAEL  
**ITALY • Headquarters**  
KENYA  
KOREA (SOUTH)  
LEBANON  
LIBYA  
LITHUANIA  
MALAYSIA  
MAURITIUS  
MEXICO  
MOROCCO  
NEW ZEALAND  
NORWAY  
PAKISTAN  
PARAGUAY  
PERU  
POLAND  
PORTUGAL  
ROMANIA  
RUSSIA  
SAUDI ARABIA  
SERBIA  
SINGAPORE  
SLOVAKIA  
SLOVENIA  
SOUTH AFRICA  
SPAIN  
SWEDEN  
SWITZERLAND  
TAIWAN  
THAILAND  
TUNISIA  
TURKEY  
UKRAINE  
UNITED ARAB EMIRATES  
UNITED KINGDOM  
URUGUAY  
**USA • Branch**  
VIETNAM



India Branch:

**MGM-VARVEL** Power Transmission Pvt Ltd  
Warehouse N. G3 and G4 ▪ Ground Floor  
Indus Valley's Logistic Park ▪ Unit 3  
Mel Ayanambakkam ▪ Vellala Street  
Chennai - 600 095 ▪ Tamil Nadu, INDIA  
info@mgmvarvelindia.com  
www.mgmvarvelindia.com

USA Branch:

**VARVEL USA** LLC  
2815 Colonnades Court  
Peachtree Corners, GA 30071 ▪ USA  
☎ 770-217-4567  
☎ 770-255-1978  
info@varvelusa.com  
www.varvelusa.com





# VARVEL®

MOTION CONTROL SINCE 1955

technology made in Italy



**VARVEL** SpA

Via 2 Agosto 1980, 9 - Loc. Crespellano  
40053 Valsamoggia (BO) - Italy

☎ +39 051 6721811

☎ +39 051 6721825

varvel@varvel.com

www.varvel.com