

Supporti Autoallineanti

Catalogo tecnico

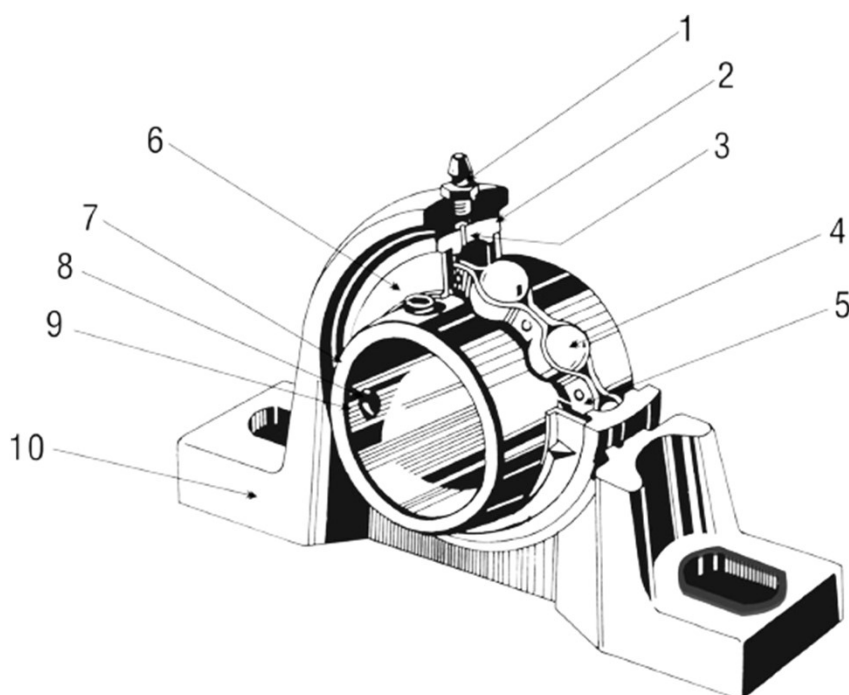





1 .Struttura del supporto

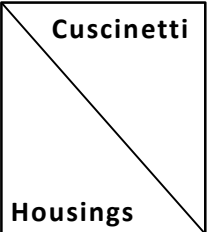

- (1) Ingrassatore
- (2) Anello esterno autoallineante
- (3) Foro per grasso
- (4) Sfera
- (5) Guarnizione in gomma
- (6) Protezione in acciaio
- (7) Anello interno
- (8) Grano
- (9) Anneal area
- (10) Carcassa in ghisa

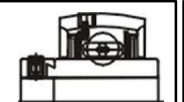
2. Tipologie di supporti

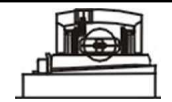
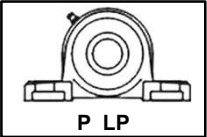
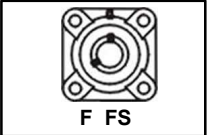
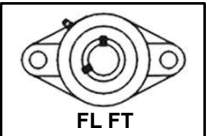
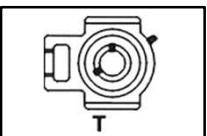
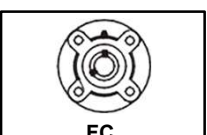
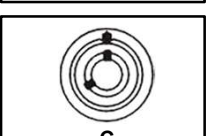
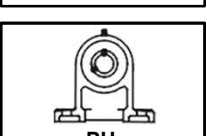
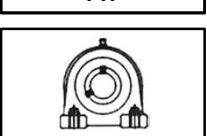
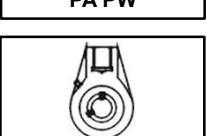
 Cuscinetti Housings	Tipo fissaggio con grano		Tipo fissaggio con eccentrico		Tipo fissaggio con bussola
					
	UCP200 UCLP200 UCP300	SBP200 SBLP200	NAP200 NAP300 NALP200	SAP200 SALP200	UKP200 UKP300 UKLP200
	UCF200 UCFS200 UCF300	SBF200	NAF200 NAF300 NAF200	SAF200	UKF200 UKF300
	UCFL200 UCFT200 UCFL300	SBFL200	NAFL200 NAFL300 NAFT200	SAFL200	UKFL200 UKFL300
	UCT200 UCT300	SBT200	NAT200 NAT300	SAT200	UKT200 UKT300
	UCFC200	SBFC200	NAFC200	SAFC200	UKFC200
	UCC200	SBC200	NAC200	SAC200	UKC200
	UCPH200	SBPH200	NAPH200	SAPH200	UKPH200
	UCPA200 UCPW200	SBPA200 SBPW200	NAPA200 NAPW200	SAPA200 SAPW200	UKPA200 UKPW200
	UCHA200	SBHA200	NAHA200	SAHA200	UKHA200

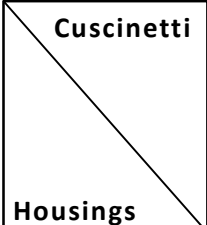
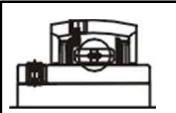
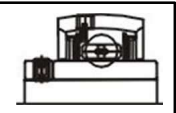
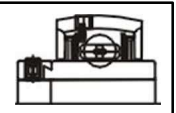
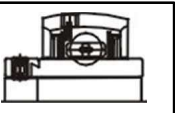
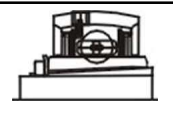
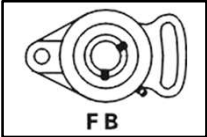
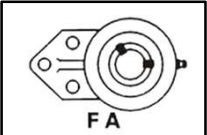
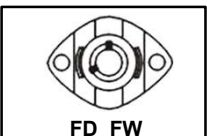
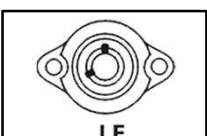
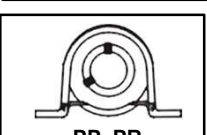
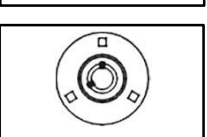
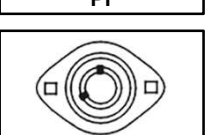
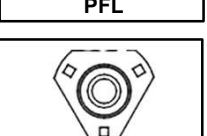
Cuscinetti  Housings	Tipo fissaggio con grano		Tipo fissaggio con eccentrico		Tipo fissaggio con bussola
	 UC200 UC300	 SB200	 NA200 NA300	 SA200	 UK200 UK300
 FB	UCFB200	SBFB200	NAFB200	SAFB200	UKFB200
 FA	UCFA200	SBFA200	NAFA200	SAFA200	UKFA200
 FD FW		SBFD200 SBFW200		SAFD200 SAFW200	
 LF		SBLF200		SALF200	
 PP PR		SBPP200 SBPR200		SAPP200 SAPR200	
 PF		SBPF200		SAPF200	
 PFL		SBPFL200		SAPFL200	
 PFT		SBPFT200		SAPFL200	

UCP 2

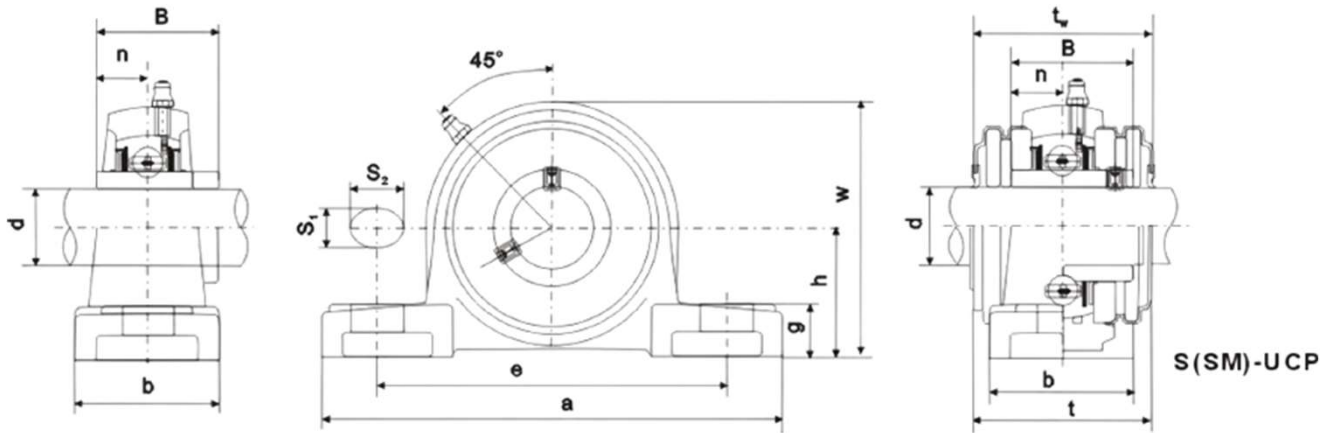

Unità	Dimensioni mm												Vite	Cuscinetto No.1)	Housing No.	Peso (Kg)
	d	h	a	e	b	S ₁	S ₂	g	w	t	B	n				
UCP201	12	30.2	127	95	38	13	19	14	62	44.5	31	12.7	M10	UC201	P203	0,69
UCP202	15	30.2	127	95	38	13	19	14	62	44.5	31	12.7	M10	UC202	P203	0,69
UCP203	17	30.2	127	95	38	13	19	14	62	44.5	31	12.7	M10	UC203	P203	0,68
UCP204	20	33.3	127	95	38	13	19	14	65	44.5	31	12.7	M10	UC204	P204	0,66
UCP205	25	36.5	140	105	38	13	19	15	71	48	34.1	14.3	M10	UC205	P205	0,81
UCP206	30	42.9	165	121	48	17	20	17	84	53	38.1	15.9	M14	UC206	P206	1,24
UCP207	35	47.6	167	127	48	17	20	18	93	59.5	42.9	17.5	M14	UC207	P207	1,58
UCP208	40	49.2	184	137	54	17	20	18	100	69	49.2	19	M14	UC208	P208	1,89
UCP209	45	54.0	190	146	54	17	20	20	106	69	49.2	19	M14	UC209	P209	2,14
UCP210	50	57.2	206	159	60	20	23	21	113	74.5	51.6	19	M16	UC210	P210	2,66
UCP211	55	63.5	219	171	60	20	23	23	125	76	55.6	22.2	M16	UC211	P211	3,31
UCP212	60	69.8	241	184	70	20	23	25	138	89	65.1	25.4	M16	UC212	P212	4,90
UCP213	65	76.2	265	203	70	25	28	27	150	89	65.1	25.4	M20	UC213	P213	5,15
UCP214	70	79.4	266	210	72	25	28	27	156	---	74.6	30.2	M20	UC214	P214	6,20
UCP215	75	82.6	275	217	74	25	28	28	162	---	77.8	33.3	M20	UC215	P215	7,16
UCP216	80	88.9	292	232	78	25	28	30	174	---	82.6	33.3	M20	UC216	P216	8,10
UCP217	85	95.2	310	247	83	25	28	32	185	---	85.7	34.1	M20	UC217	P217	9,81
UCP218	90	101.6	327	262	88	27	30	33	198	---	96	39.7	M22	UC218	P218	11,96

UKP 2

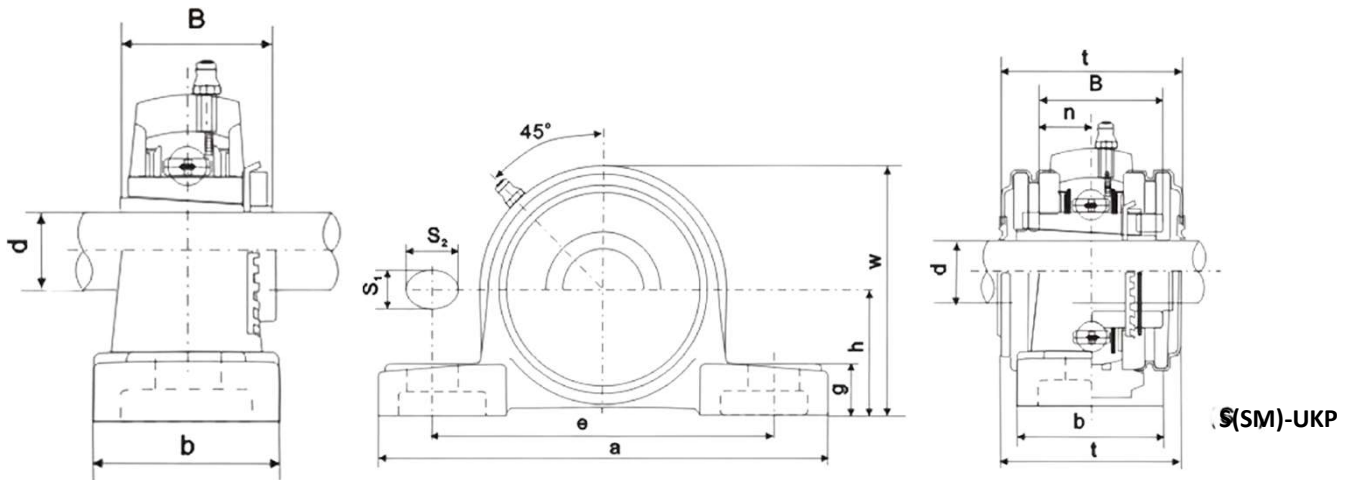

Unità + bussola		Dimensioni mm											Vite	Cuscinetto	Bussola	Housing	Peso (kg)
		d	h	a	e	b	S ₁	S ₂	g	w	t	B					
UKP205	H2305	20	36,5	140	105	38	13	19	15	71	48	35	M10	UK205	H2305	P205	0,86
UKP206	H2306	25	42,9	165	121	48	17	20	17	84	53	38	M14	UK206	H2306	P206	1,28
UKP207	H2307	30	47,6	167	127	48	17	20	18	93	59,5	43	M14	UK207	H2307	P207	1,67
UKP208	H2308	35	49,2	184	137	54	17	20	18	100	69	46	M14	UK208	H2308	P208	1,99
UKP209	H2309	40	54,0	190	146	54	17	20	20	106	69	50	M14	UK209	H2309	P209	1,29
UKP210	H2310	45	57,2	206	159	60	20	23	21	113	74,5	55	M16	UK210	H2310	P210	2,83
UKP211	H2311	50	63,5	219	171	60	20	23	23	125	76	59	M16	UK211	H2311	P211	3,46
UKP212	H2312	55	69,8	241	184	70	20	23	25	138	89	62	M16	UK212	H2312	P212	4,95
UKP213	H2313	60	76,2	265	203	70	25	28	27	150	89	65	M20	UK213	H2313	P213	5,06
UKP215	H2315	65	82,6	275	217	74	25	28	28	162	-	73	M20	UK215	H2315	P215	7,27
UKP216	H2316	70	88,9	292	232	78	25	28	30	174	—	78	M20	UK216	H2316	P216	8,36
UKP217	H2317	75	95,2	310	247	83	25	28	32	185	-	82	M20	UK217	H2317	P217	10,23
UKP218	H2318	80	101,6	327	262	88	27	30	33	198	—	86	M22	UK218	H2318	P218	12,34

UCP 3 – serie pesante

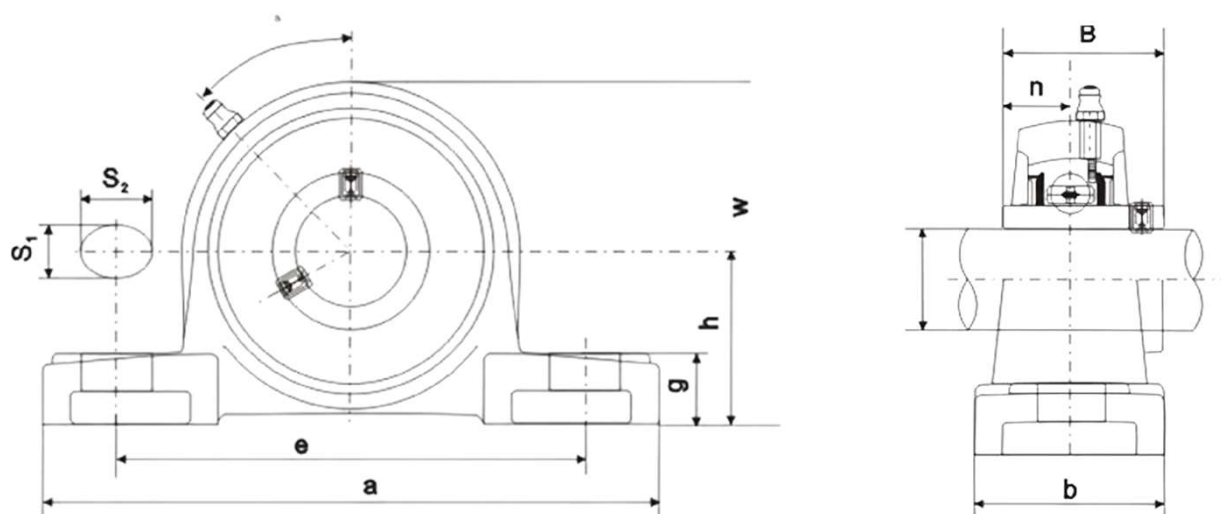

Unità No.	Dimensioni mm											Vite	Cuscinetto	Housing	Peso (Kg)
	d	h	a	e	b	S ₁	S ₂	g	w	B	n				
UCP305	25	45	175	132	45	17	20	15	85	38	38	M14	UC305	P305	1,4
UCP306	30	50	180	140	50	17	20	18	95	43	17	M14	UC306	P306	1,8
UCP307	35	56	210	160	56	17	25	20	106	48	19	M14	UC307	P307	2,8
UCP308	40	60	220	170	60	17	27	22	116	52	19	M14	UC308	P308	3,0
UCP309	45	67	245	190	67	20	30	24	129	57	22	M16	UC309	P309	4,1
UCP310	50	75	275	212	75	20	35	27	143	61	22	M16	UC310	P310	5,8
UCP311	55	80	310	236	80	20	38	30	154	66	25	M16	UC311	P311	7,4
UCP312	60	85	330	250	85	25	38	32	165	71	26	M20	UC312	P312	9,4
UCP313	65	90	340	260	90	25	38	33	176	75	30	M20	UC313	P313	10
UCP314	70	95	360	280	90	27	40	35	187	78	33	M22	UC314	P314	12
UCP315	75	100	380	290	100	27	40	35	198	82	32	M22	UC315	P315	14
UCP316	80	106	400	300	110	27	40	40	210	86	34	M22	UC316	P316	18
UCP317	85	112	420	320	110	33	45	40	220	96	40	M27	UC317	P317	20
UCP318	90	118	430	330	110	33	45	45	235	96	40	M27	UC318	P318	24
UCP319	95	125	470	360	120	36	50	45	250	103	41	M30	UC319	P319	29

UCF 2 – flangia quadra

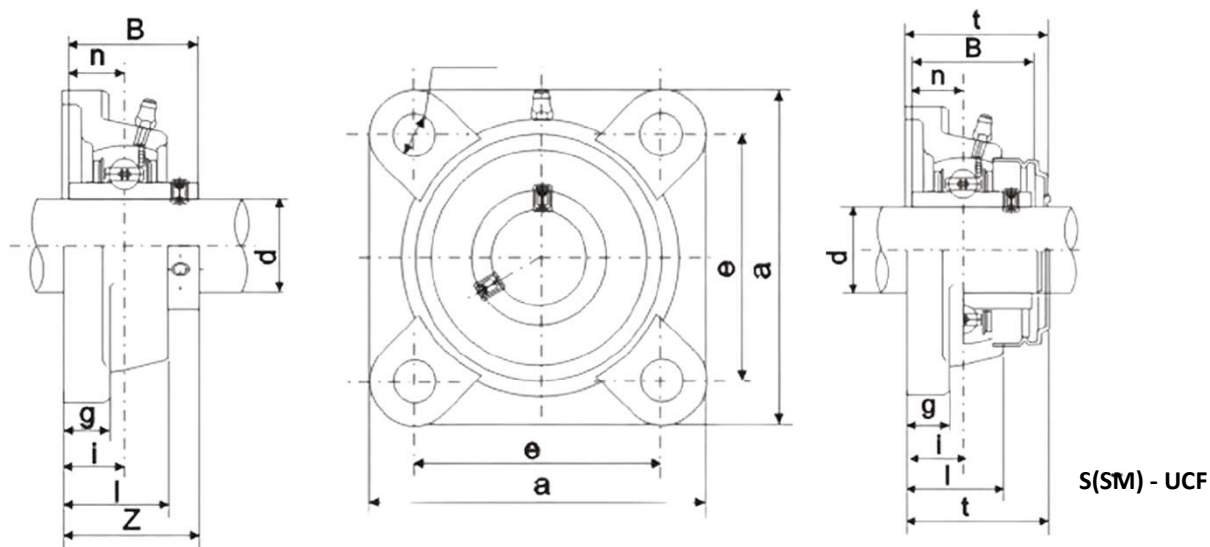

Unità No.	Dimensioni mm											Vite	Cuscinetto	Housing No.	Peso (kg)
	d	a	e	i	g	l	s	z	t	B	n				
UCF201	12	86	64	15	12	25,5	12	33,3	37,5	31	12,7	M10	UC201	F204	0,60
UCF202	15	86	64	15	12	25,5	12	33,3	37,5	31	12,7	M10	UC202	F204	0,59
UCF203	17	86	64	15	12	25,5	12	33,3	37,5	31	12,7	M10	UC203	F204	0,58
UCF204	20	86	64	15	12	25,5	12	33,3	37,5	31	12,7	M10	UC204	F204	0,56
UCF205	25	95	70	16	14	27	12	35,8	40	34,1	14,3	M10	UC205	F205	0,80
UCF206	30	108	83	18	14	31	12	40,2	44,5	38,1	15,9	M10	UC206	F206	1,12
UCF207	35	117	92	19	16	34	14	44,4	48,5	42,9	17,5	M12	UC207	F207	1,46
UCF208	40	130	102	21	16	36	16	51,2	55,5	49,2	19	M14	UC208	F208	1,84
UCF209	45	137	105	22	18	38	16	52,2	56,5	49,2	19	M14	UC209	F209	2,15
UCF210	50	143	111	22	18	40	16	54,6	59,5	51,6	19	M14	UC210	F210	2,42
UCF211	55	162	130	25	20	43	19	58,4	63	55,6	22,2	M16	UC211	F211	3,31
UCF212	60	175	143	29	20	48	19	68,7	73,5	65,1	25,4	M16	UC212	F212	4,28
UCF213	65	187	149	30	22	50	19	69,7	74,5	65,1	25,4	M16	UC213	F213	4,99
UCF214	70	193	152	31	22	54	19	75,4	81,5	74,6	30,2	M16	UC214	F214	5,85
UCF215	75	200	159	34	22	56	19	78,5	83,5	77,8	33,3	M16	UC215	F215	6,91
UCF216	80	208	165	34	22	58	23	83,3	88,5	82,6	33,3	M20	UC216	F216	7,50
UCF217	85	220	175	36	24	63	23	87,6	92,6	85,7	34,1	M20	UC217	F217	9,66
UCF218	90	235	187	40	24	68	23	96,3	101,5	96	39,7	M20	UC218	F218	12,06

UKF 2 – flangia quadra

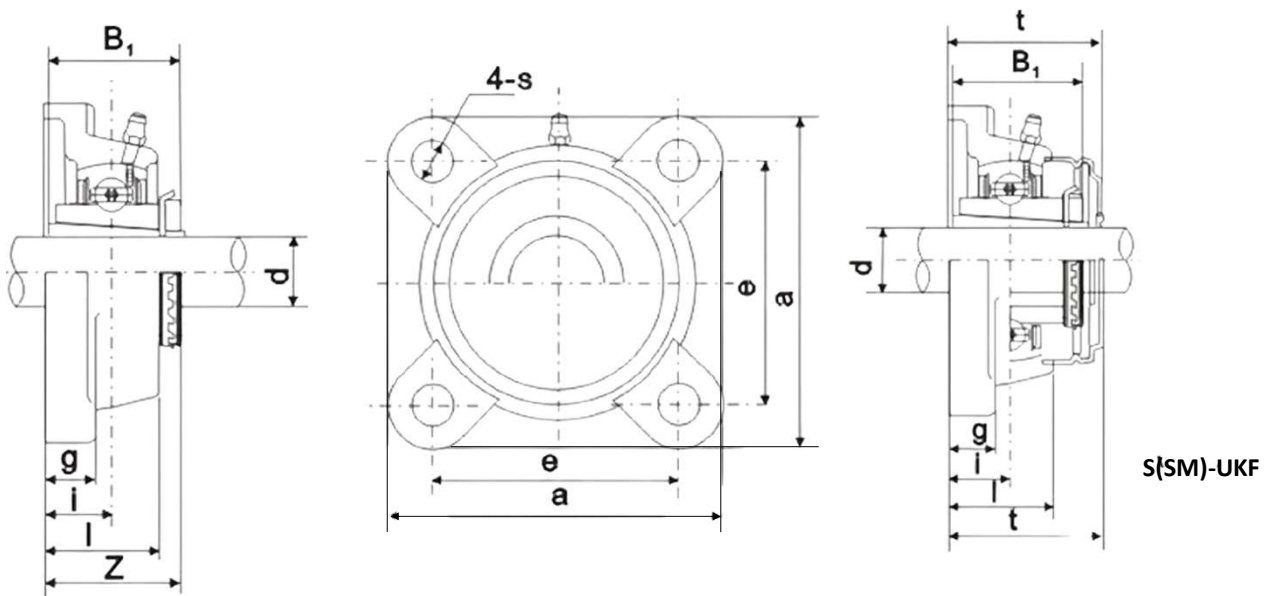

Unità + bussola		Dimensioni (mm)										Vite	Cuscinetto + bussola		Housing No.	Peso (kg)
		d	a	e	i	g	l	s	z	t	B ₁					
UKF205	H2305	20	95	70	16	14	27	12	35,5	40	35	M10	UK205	H2305	F205	0,85
UKF206	H2306	25	108	83	18	14	31	12	39	44,5	38	M10	UK206	H2306	F206	1,16
UKF207	H2307	30	117	92	19	16	34	14	42,5	48,5	43	M12	UK207	H2307	F207	1,55
UKF208	H2308	35	130	102	21	16	36	16	46,5	55,5	46	M14	UK208	H2308	F208	1,94
UKF209	H2309	40	137	105	22	18	38	16	48,5	56,5	50	M14	UK209	H2309	F209	2,30
UKF210	H2310	45	143	111	22	18	40	16	50	59,5	55	M14	UK210	H2310	F210	2,59
UKF211	H2311	50	162	130	25	20	43	19	54,5	63	59	M16	UK211	H2311	F211	3,46
UKF212	H2312	55	175	143	29	20	48	19	61	73,5	62	M16	UK212	H2312	F212	4,33
UKF213	H2313	60	187	149	30	22	50	19	64	74,5	65	M16	UK213	H2313	F213	4,90
UKF215	H2315	65	200	159	34	22	56	19	71	83,5	73	M16	UK215	H2315	F215	7,02
UKF216	H2316	70	208	165	34	22	58	23	73,5	88,5	78	M20	UK216	H2316	F216	7,76
UKF217	H2317	75	220	175	36	24	63	23	77	92,6	82	M20	UK217	H2317	F217	10,08
UKF218	H2318	80	235	187	40	24	68	23	81,5	101,5	86	M20	UK218	H2318	F218	12,44

UCF 3 – flangia quadra

serie pesante

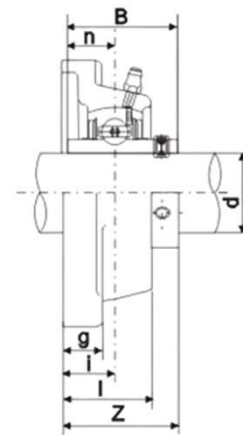
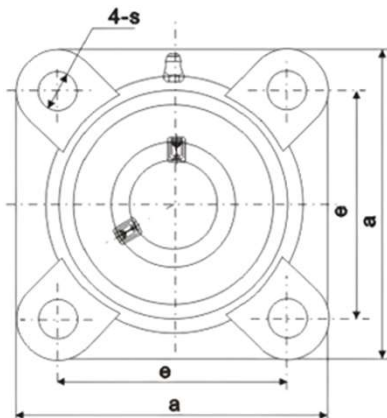

Unità No.	Dimensions mm										Vite	Cuscinetto	Housing No.	Peso (kg)
	d	a	e	i	g	l	s	z	B	n				
UCF305	25	110	80	16	13	29	16	39	38	15	M14	UC305	F305	1,1
UCF306	30	125	95	18	15	32	16	44	43	17	M14	UC306	F306	1,6
UCF307	35	135	100	20	16	36	19	49	48	19	M16	UC307	F307	2
UCF308	40	150	112	23	17	40	19	56	52	19	M16	UC308	F308	2,7
UCF309	45	160	125	25	18	44	19	60	57	22	M16	UC309	F309	3,4
UCF310	50	175	132	28	19	48	23	67	61	22	M20	UC310	F310	4,5
UCF311	55	185	140	30	20	52	23	71	66	25	M20	UC311	F311	5,5
UCF312	60	195	150	33	22	56	23	78	71	26	M20	UC312	F312	6,5
UCF313	65	208	166	33	22	58	23	78	75	30	M20	UC313	F313	7,9
UCF314	70	226	178	36	25	61	25	81	78	33	M22	UC314	F314	9,5
UCF315	75	236	184	39	25	66	25	89	82	32	M22	UC315	F315	12
UCF316	80	250	196	38	27	68	31	90	86	34	M27	UC316	F316	14
UCF317	85	260	204	44	27	74	31	100	96	40	M27	UC317	F317	16
UCF318	90	280	216	44	30	76	35	100	96	40	M30	UC318	F318	19
UCF319	95	290	228	59	30	94	35	121	103	41	M30	UC319	F319	22

UCFL 2 – flangia ovale

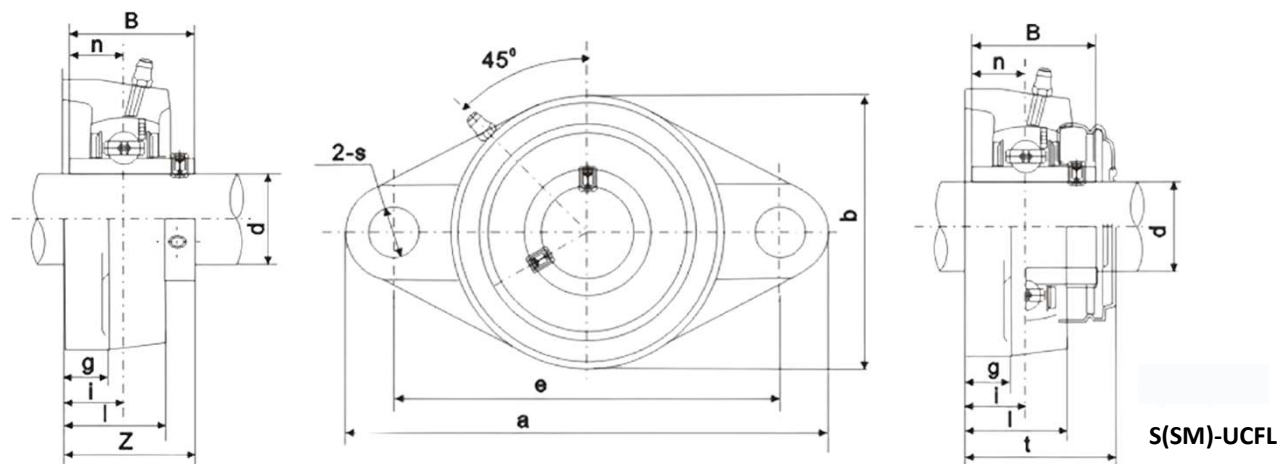

Unità No.	Dimensioni mm												Vite	Cuscinetto	Housing NO.	Peso (kg)
	d	a	e	i	g	l	s	b	z	t	B	n				
UCFL201	12	113	90	15	11	25,5	12	60	33,3	37,5	31	12,7	M10	UC201	FL204	0,45
UCFL202	15	113	90	15	11	25,5	12	60	33,3	37,5	31	12,7	M10	UC202	FL204	0,44
UCFL203	17	113	90	15	11	25,5	12	60	33,3	37,5	31	12,7	M10	UC203	FL204	0,43
UCFL204	20	113	90	15	11	25,5	12	60	33,3	37,5	31	12,7	M10	UC204	FL204	0,41
UCFL205	25	130	99	16	13	27	16	68	35,8	40	34,1	14,3	M14	UC205	FL205	0,58
UCFL206	30	148	117	18	13	31	16	80	40,2	44,5	38,1	15,9	M14	UC206	FL206	0,86
UCFL207	35	161	130	19	14	34	16	90	44,4	48,5	42,9	17,5	M14	UC207	FL207	1,08
UCFL208	40	175	144	21	14	36	16	100	51,2	55,5	49,2	19	M14	UC208	FL208	1,44
UCFL209	45	188	148	22	15	38	19	108	52,2	56,5	49,2	19	M16	UC209	FL209	1,74
UCFL210	50	197	157	22	15	40	19	115	54,6	59,5	51,6	19	M16	UC210	FL210	2,10
UCFL211	55	224	184	25	18	43	19	130	58,4	63	55,6	22,2	M16	UC211	FL211	2,91
UCFL212	60	250	202	29	18	48	23	140	68,7	73,5	65,1	25,4	M20	UC212	FL212	3,74
UCFL213	65	258	210	30	22	50	23	155	69,7	74,5	65,1	25,4	M20	UC213	FL213	4,57
UCFL214	70	265	216	31	22	54	23	160	75,4	-	74,6	30,2	M20	UC214	FL214	5,11
UCFL215	75	275	225	34	22	56	23	165	78,5	-	77,8	33,3	M20	UC215	FL215	5,37
UCFL216	80	290	233	34	22	58	25	180	83,3	-	82,6	33,3	M22	UC216	FL216	7,20
UCFL217	85	305	248	36	24	63	25	190	87,6	-	85,7	34,1	M22	UC217	FL217	8,61
UCFL218	90	320	265	40	24	68	25	205	96,3	-	96	39,7	M22	UC218	FL218	10,51

UKFL 2 – flangia ovale

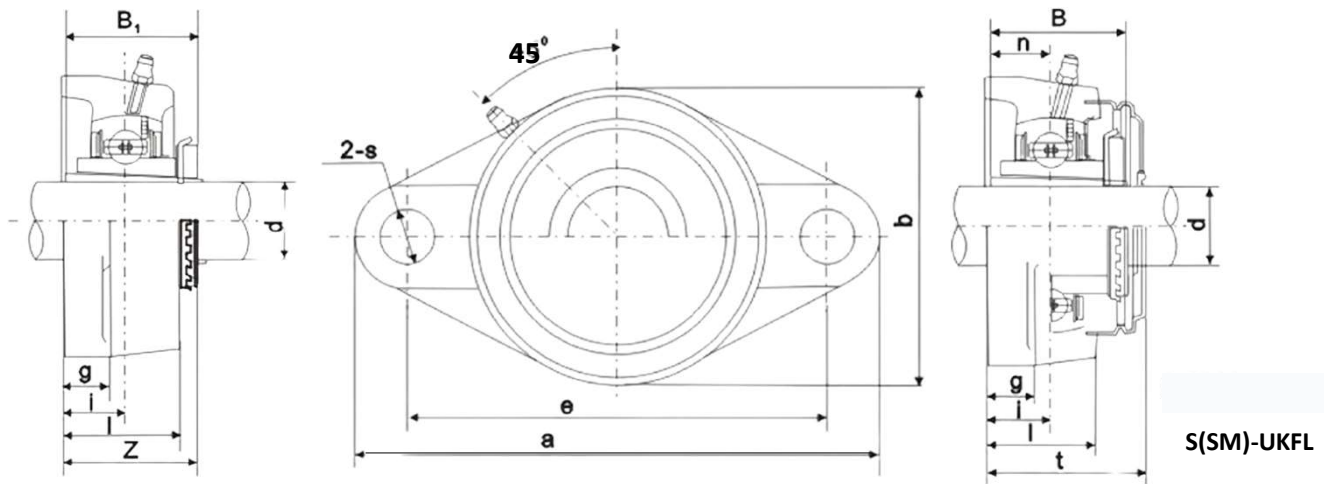

Unità No.		Dimensioni mm											Vite	Cuscinetto + bussola		Housing No.	Peso (kg)
		d	a	e	i	g	l	s	b	z	t	B ₁					
UKFL205	H2305	20	130	99	16	13	27	16	68	35,5	40	35	M14	UK205	H2305	FL205	0,63
UKFL206	H2306	25	148	117	18	13	31	16	80	39	44,5	38	M14	UK206	H2306	FL206	0,90
UKFL207	H2307	30	161	130	19	14	34	16	90	42,5	48,5	43	M14	UK207	H2307	FL207	1,17
UKFL208	H2308	35	175	144	21	14	36	16	100	46,5	55,5	46	M14	UK208	H2308	FL208	1,54
UKFL209	H2309	40	188	148	22	15	38	19	108	48,5	56,5	50	M16	UK209	H2309	FL209	1,89
UKFL210	H2310	45	197	157	22	15	40	19	115	50	59,5	55	M16	UK210	H2310	FL210	2,27
UKFL211	H2311	50	224	184	25	18	43	19	130	54,5	63	59	M16	UK211	H2311	FL211	3,06
UKFL212	H2312	55	250	202	29	18	48	23	140	61	73,5	62	M20	UK212	H2312	FL212	3,79
UKFL213	H2313	60	258	210	30	22	50	23	155	64	74,5	65	M20	UK213	H2313	FL213	4,48
UKFL215	H2315	65	275	225	34	22	56	23	165	71	—	73	M20	UK215	H2315	FL215	5,48
UKFL216	H2316	70	290	233	34	22	58	25	180	73,5	-	78	M22	UK216	H2316	FL216	7,46
UKFL217	H2317	75	305	248	36	24	63	25	190	77	-	82	M22	UK217	H2317	FL217	9,03
UKFL218	H2318	80	320	265	40	24	68	25	205	81,5	—	86	M22	UK218	H2318	FL218	10,89

UCFL 3 – flangia ovale

serie pesante

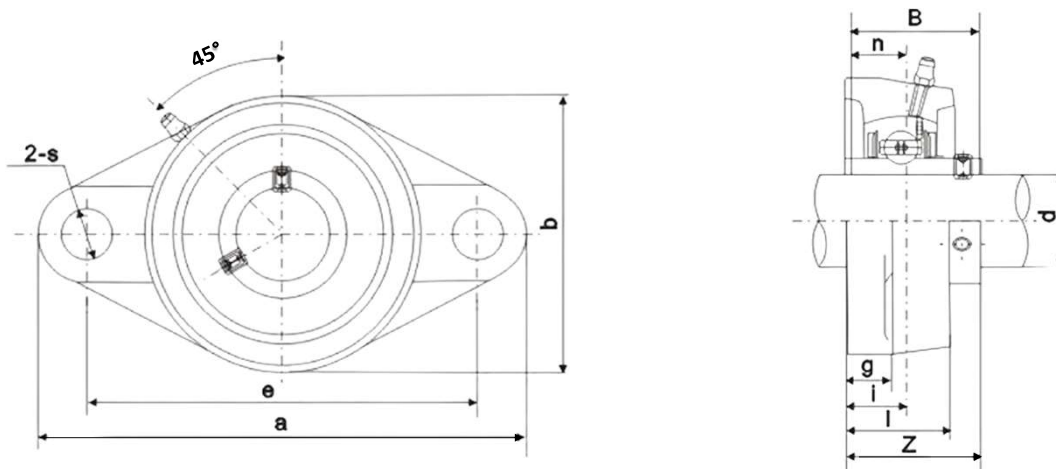

Unità No.	Dimensioni mm											Vite	Cuscinetto	Housing No.	Peso (kg)
	d	a	e	i	g	l	s	b	z	B	n				
UCFL305	25	150	113	16	13	29	19	80	39	38	15	M16	UC305	FL305	1,1
UCFL306	30	180	134	18	15	32	23	90	44	43	17	M20	UC305	FL306	1,5
UCFL307	35	185	141	20	16	36	23	100	49	48	19	M20	UC307	FL307	1,9
UCFL308	40	200	158	23	17	40	23	112	56	52	19	M20	UC308	FL308	2,5
UCFL309	45	230	177	25	18	44	25	125	60	57	22	M22	UC309	FL309	3,4
UCFL310	50	240	187	28	19	48	25	140	67	61	22	M22	UC310	FL310	4,4
UCFL311	55	250	198	30	20	52	25	150	70	66	25	M22	UC311	FL311	5,1
UCFL312	60	270	212	33	22	56	31	160	78	71	26	M27	UC312	FL312	6,1
UCFL313	65	295	240	33	25	58	31	175	78	75	30	M27	UC313	FL313	7,8
UCFL314	70	315	250	36	28	61	35	185	80	78	33	M30	UC314	FL314	9,0
UCFL315	75	320	260	39	30	66	35	195	89	82	32	M30	UC315	FL315	10
UCFL316	80	355	285	38	32	68	38	210	90	86	34	M33	UC316	FL316	13
UCFL317	85	370	300	44	32	74	38	220	100	96	40	M33	UC317	FL317	15
UCFL318	90	385	315	44	36	76	38	235	100	96	40	M33	UC318	FL318	18
UCFL319	95	405	330	59	40	94	41	250	121	103	41	M36	UC319	FL319	22

UCT 2

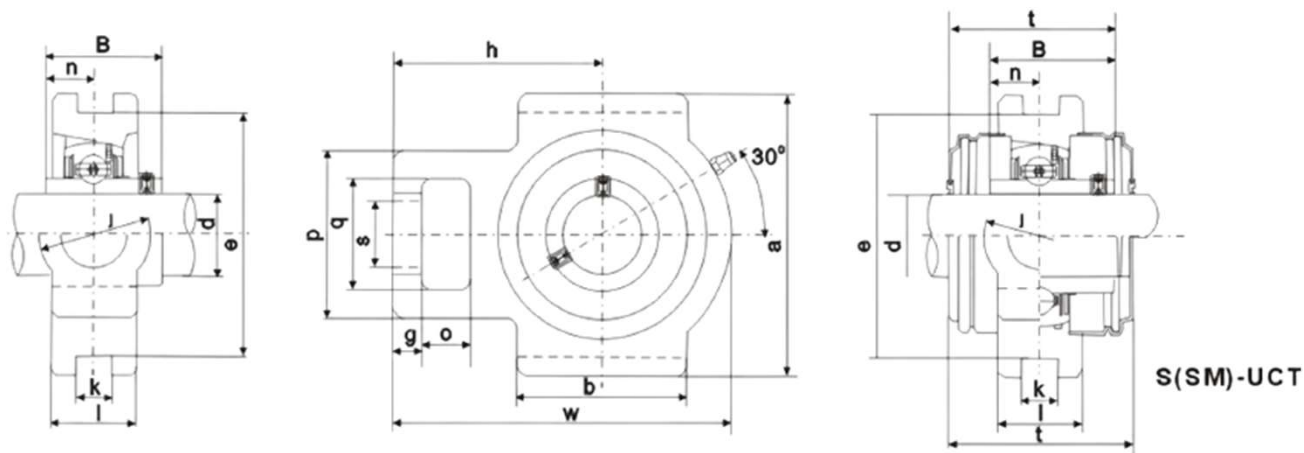

Unità No.	Dimensioni mm																	Bearing No.1)	Housing No.	Weight (kg)
	d	o	g	P	q	s	b	k	e	a	w	j	l	h	t	B	N			
UCT201	12	16	10	51	32	19	51	12	76	89	94	32	21	61	44,5	31	12,7	UC201	T204	0,80
UCT202	15	16	10	51	32	19	51	12	76	89	94	32	21	61	44,5	31	12,7	UC202	T204	0,79
UCT203	17	16	10	51	32	19	51	12	76	89	94	32	21	61	44,5	31	12,7	UC203	T204	0,78
UCT204	20	16	10	51	32	19	51	12	76	89	94	32	21	61	44,5	31	12,7	UC204	T204	0,76
UCT205	25	16	10	51	32	19	51	12	76	89	97	32	24	62	48	34,1	14,3	UC205	T205	0,81
UCT206	30	16	10	56	37	22	57	12	89	102	113	37	28	70	53	38,1	15,9	UC206	T206	1,22
UCT207	35	16	13	64	37	22	64	12	89	102	129	37	30	78	59,5	42,9	17,5	UC207	T207	1,44
UCT208	40	19	16	83	49	29	83	16	102	114	144	49	33	89	69	49,2	19	UC208	T208	2,40
UCT209	45	19	16	83	49	29	83	16	102	117	144	49	35	87	69	49,2	19	UC209	T209	2,36
UCT210	50	19	16	83	49	29	86	16	102	117	149	49	37	90	74,5	51,6	19	UC210	T210	2,43
UCT211	55	25	19	102	64	35	95	22	130	146	171	64	38	106	76	55,6	22,2	UC211	T211	4,11
UCT212	60	32	19	102	64	35	102	22	130	146	194	64	42	119	89	65,1	25,4	UC212	T212	4,97
UCT213	65	32	21	111	70	41	121	26	151	167	224	70	44	137	89	65,1	25,4	UC213	T213	6,65
UCT214	70	32	21	111	70	41	121	26	151	167	224	70	46	137	-	74,6	30,2	UC214	T214	7,05
UCT215	75	32	21	111	70	41	121	26	151	167	232	70	48	140	-	77,8	33,3	UC215	T215	7,41
UCT216	80	32	21	111	70	41	121	26	165	184	235	70	51	140	-	82,6	33,3	UC216	T216	8,30
UCT217	85	38	29	124	73	48	157	30	173	198	260	73	54	162	-	85,7	34,1	UC217	T217	11,00

UCFC 2 – flangia tonda

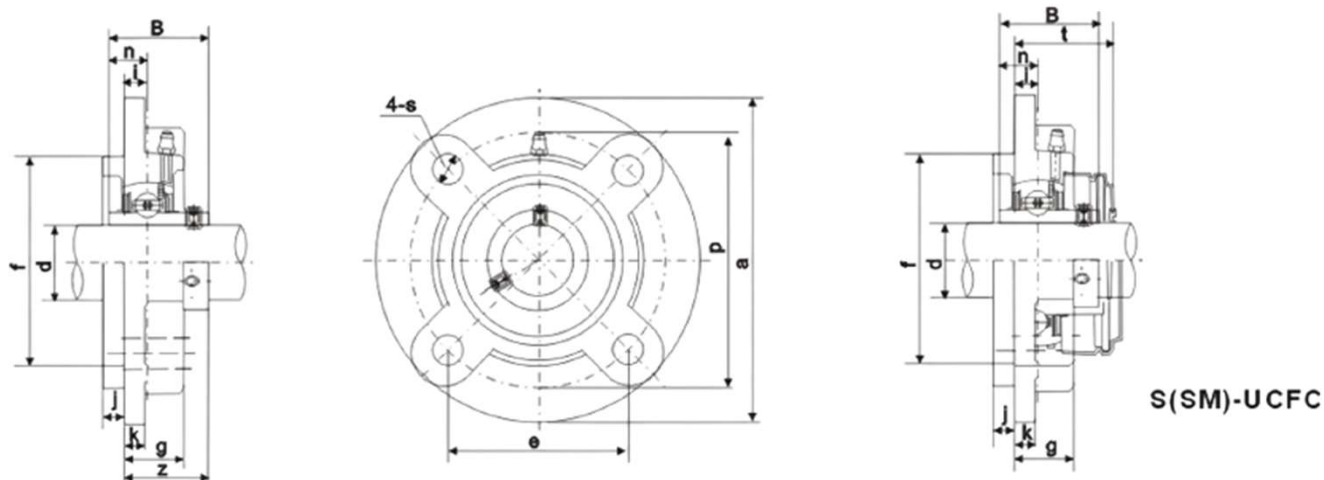

Unità No.	Dimensioni mm														Vite	Cuscinetto	Housing No.	Peso (Kg)
	d	a	P	e	i	s	J	k	g	f	z	t	B	n				
UCFC201	12	100	78	55,1	10	12	5	7	20,5	62	28,3	32,5	31	12,7	M10	UC201	FC204	0,73
UCFC202	15	100	78	55,1	10	12	5	7	20,5	62	28,3	32,5	31	12,7	M10	UC202	FC204	0,72
UCFC203	17	100	78	55,1	10	12	5	7	20,5	62	28,3	32,5	31	12,7	M10	UC203	FC204	0,71
UCFC204	20	100	78	55,1	10	12	5	7	20,5	62	28,3	32,5	31	12,7	M10	UC204	FC204	0,69
UCFC205	25	115	90	63,6	10	12	6	7	21	70	29,8	34	34,1	14,3	M10	UC205	FC205	1,00
UCFC206	30	125	100	70,7	10	12	8	8	23	80	32,2	36,5	38,1	15,9	M10	UC206	FC206	1,30
UCFC207	35	135	110	77,8	11	14	8	9	26	90	36,4	41	42,9	17,5	M12	UC207	FC207	1,81
UCFC208	40	145	120	84,8	11	14	10	9	26	100	41,2	45,5	49,2	19	M12	UC208	FC208	2,14
UCFC209	45	160	132	93,3	10	16	12	14	26	105	40,2	44,5	49,2	19	M14	UC209	FC209	2,68
UCFC210	50	165	138	97,6	10	16	12	14	28	110	42,6	47,5	51,6	19	M14	UC210	FC210	2,90
UCFC211	55	185	150	106,1	13	19	12	15	31	125	46,4	51	55,6	22,2	M16	UC211	FC211	4,01
UCFC212	60	195	160	113,1	17	19	12	15	36	135	56,7	61,5	65,1	25,4	M16	UC212	FC212	4,94
UCFC213	65	205	170	120,2	16	19	14	15	36	145	55,7	60,5	65,1	25,4	M16	UC213	FC213	5,65
UCFC214	70	215	177	125,1	17	19	14	18	40	150	61,4	—	74,6	30,2	M16	UC214	FC214	6,95
UCFC215	75	220	184	130,1	18	19	16	18	40	160	62,5	-	77,8	33,3	M16	UC215	FC215	7,56
UCFC216	80	240	200	141,4	18	23	16	18	42	170	67,3	-	82,6	33,3	M20	UC216	FC216	9,15
UCFC217	85	250	208	147,1	18	23	18	20	45	180	69,6	-	85,7	34,1	M20	UC217	FC217	10,81
UCFC218	90	265	220	155,5	22	23	18	20	50	190	78,3	-	96	39,7	M20	UC218	FC218	12,96

UKFC 2 – flangia tonda

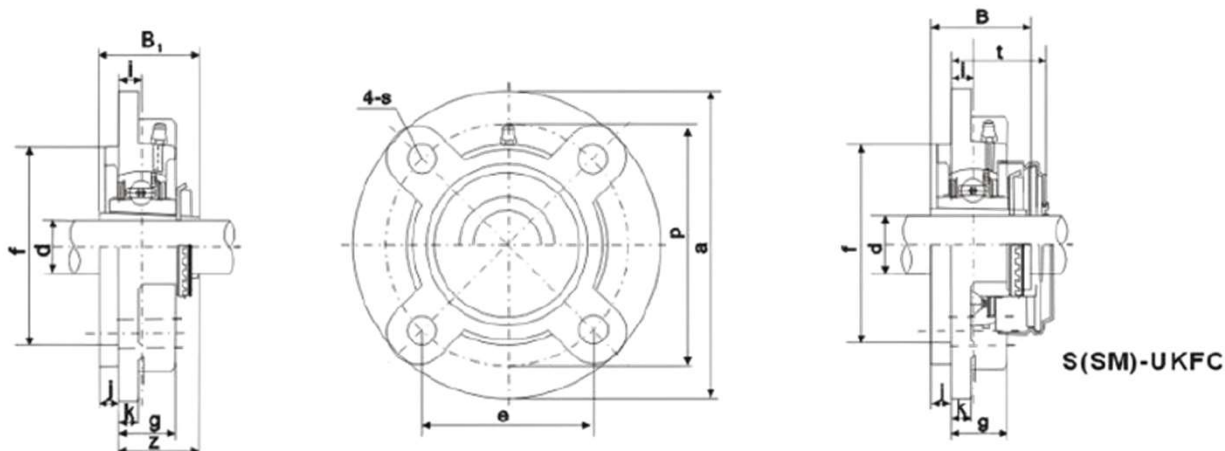

Unità + bussola		Dimensioni mm													Vite	Cuscinetto	Bussola	Housing	Peso (kg)
		d	a	p	e	i	s	j	k	g	f	z	t	B ₁					
UKFC205	H2305	20	115	90	63,6	10	12	6	7	21	70	29,5	34	35	M10	UK205	H2305	FC205	1,05
UKFC206	H2306	25	125	100	70,7	10	12	8	8	23	80	31	36,5	38	M10	UK206	H2306	FC206	1,34
UKFC207	H2307	30	135	110	77,8	11	14	8	9	26	90	33,5	41	43	M12	UK207	H2307	FC207	1,90
UKFC208	H2308	35	145	120	84,8	11	14	10	9	26	100	35,5	45,5	46	M12	UK208	H2308	FC208	2,24
UKFC209	H2309	40	160	132	93,3	10	16	12	14	26	105	36	44,5	50	M14	UK209	H2309	FC209	2,83
UKFC210	H2310	45	165	138	97,6	10	16	12	14	28	110	37,5	47,5	55	M14	UK210	H2310	FC210	3,07
UKFC211	H2311	50	185	150	106,1	13	19	12	15	31	125	41,5	51	59	M16	UK211	H2311	FC211	4,16
UKFC212	H2312	55	195	160	113,1	17	19	12	15	36	135	48	61,5	62	M16	UK212	H2312	FC212	4,99
UKFC213	H2313	60	205	170	120,2	16	19	14	15	36	145	49	60,5	65	M16	UK213	H2313	FC213	5,56
UKFC215	H2315	65	220	184	130,1	18	19	16	18	40	160	53,5	-	73	M16	UK215	H2315	FC215	7,67
UKFC216	H2316	70	240	200	141,4	18	23	16	18	42	170	57	-	78	M20	UK216	H2316	FC216	9,41
UKFC217	H2317	75	250	208	147,1	18	23	18	20	45	180	59	-	82	M20	UK217	H2317	FC217	11,23
UKFC218	H2318	80	265	220	155,5	22	23	18	20	50	190	64,5	-	86	M20	UK218	H2318	FC218	13,34

UKC 2

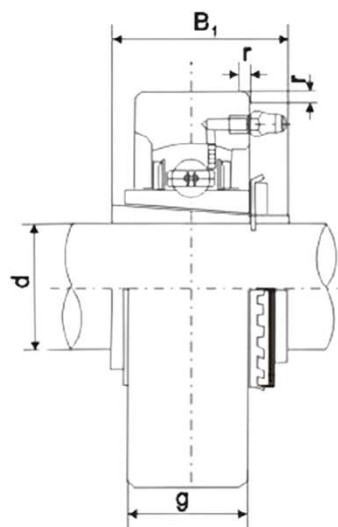
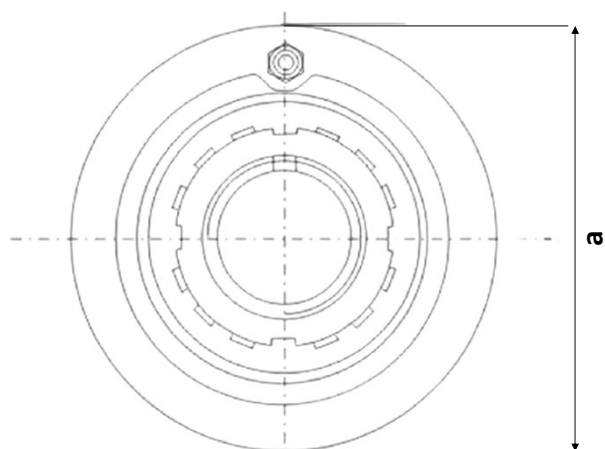

Unità + bussola		Dimensioni mm					Cuscinetto	Bussola	Housing No.	Peso (Kg)
		d	a	g	r	B ₁				
UKC205	H2305	20	80	22	2	35	UK205	H2305	C205	0,68
UKC206	H2306	25	85	27	2	38	UK206	H2306	C206	0,84
UKC207	H2307	30	90	28	2	43	UK207	H2307	C207	1,02
UKC208	H2308	35	100	30	25	46	UK208	H2308	C208	1,32
UKC209	H2309	40	110	31	2.5	50	UK209	H2309	C209	1,64
UKC210	H2310	45	120	33	2.5	55	UK210	H2310	C210	2,07
UKC211	H2311	50	125	35	25	59	UK211	H2311	C211	2,33
UKC212	H2312	55	130	38	25	62	UK212	H2312	C212	2,57
UKC213	H2313	60	140	40	3	65	UK213	H2313	C213	2,89

UCPA 2

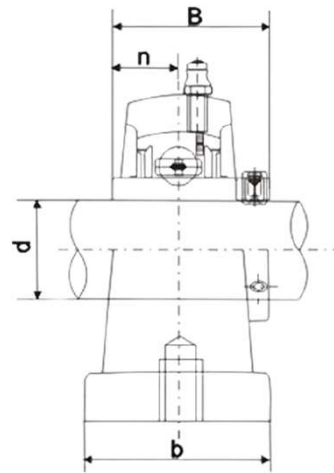
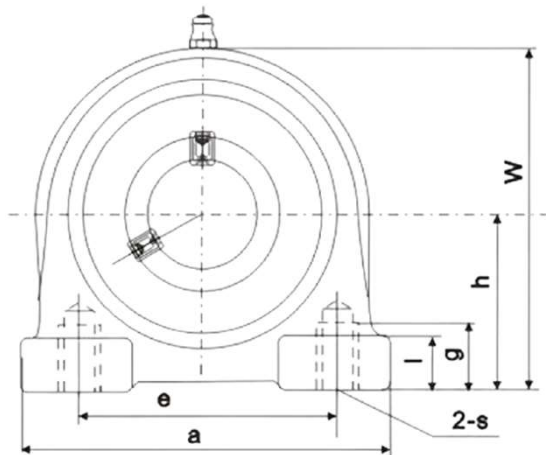

Unità	Dimensioni mm											Cuscinetto	Housing No.	Weight (kg)
	d	h	a	e	b	s	g	l	w	B	n			
UCPA201	12	30.2	76	52	40	M10	15	11	62	31	12,7	UC201	PA204	0,6
UCPA202	15	30.2	76	52	40	M10	15	11	62	31	12,7	UC202	PA204	0,59
UCPA203	17	30.2	76	52	40	M10	15	11	62	31	12,7	UC203	PA204	0,58
UCPA204	20	30.2	76	52	40	M10	15	11	62	31	12,7	UC204	PA204	0,56
UCPA205	25	36.5	84	56	38	M10	15	12	72	34,1	14,3	UC205	PA205	0,83
UCPA206	30	42.9	94	66	50	M14	18	12	84	38,1	15,9	UC206	PA206	1,12
UCPA207	35	47.6	110	80	55	M14	20	13	95	42,9	17,5	UC207	PA207	1,48
UCPA208	40	49.2	116	84	58	M14	20	13	100	49,2	19	UC208	PA208	1,89
UCPA209	45	54.2	120	90	60	M14	25	13	108	49,2	19	UC209	PA209	1,98
UCPA210	50	57.2	130	94	64	M16	25	14	116	51,6	19	UC210	PA210	2,16
UCPA211	55	63.5	140	104	66	M16	25	14	125	55,6	22,2	UC211	PA211	3,26
UCPA212	60	69.9	150	114	68	M16	25	15	138	65,1	25,4	UC212	PA212	4,19
UCPA213	65	76.2	160	124	70	M16	25	15	150	65,1	25,4	UC213	PA213	—

Note: 1. UC201 → 203 hanno lo stesso Ø esterno dell' UC204.

UCPH 2

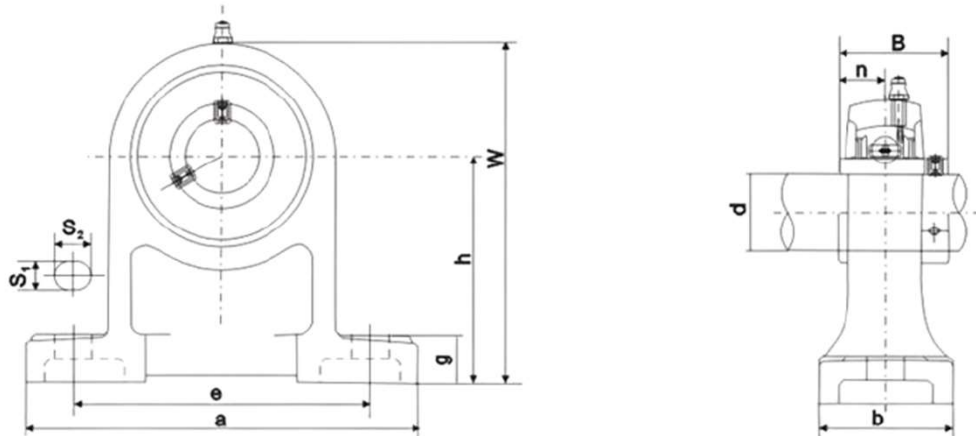

Unità	Dimensioni mm											Vite	Cuscinetto	Housing	Peso (kg)
	d	h	a	e	b	S ₁	S ₂	g	w	B	n				
UCPH201	12	70	127	95	40	13	19	15	101	31	12,7	M10	UC201	PH204	0,18
UCPH202	15	70	127	95	40	13	19	15	101	31	12,7	M10	UC202	PH204	0,80
UCPH203	17	70	127	95	40	13	19	15	101	31	12,7	M10	UC203	PH204	0,79
UCPH204	20	70	127	95	40	13	19	15	101	31	12,7	M10	UC204	PH204	0,77
UCPH205	25	80	140	105	50	13	19	16	114	34,1	14,3	M10	UC205	PH205	1,01
UCPH206	30	90	161	121	50	17	21	17	130	38,1	15,9	M14	UC206	PH206	1,47
UCPH207	35	95	166	127	60	17	21	18	140	42,9	17,5	M14	UC207	PH207	1,91
UCPH208	40	100	178	137	70	17	21	19	150	49,2	19	M14	UC208	PH208	2,52
UCPH209	45	105	189	146	70	17	21	20	158	49,2	19	M16	UC209	PH209	2,72
UCPH210	50	110	205	159	70	20	23	21	165	51,6	19	M16	UC210	PH210	3,10
UCPH211	55	120	219	171	75	20	23	22	181	55,6	22,2	M16	UC211	PH211	-
UCPH212	60	130	241	184	85	20	23	25	197	65,1	25,4	M16	UC212	PH212	-
UCPH213	65	140	265	203	95	25	28	27	212	65,1	25,4	M20	UC213	PH213	-
UCPH214	70	150	266	210	105	25	28	28	225	74,6	30,2	M20	UC214	PH214	-
UCPH215	75	160	275	217	115	25	28	29	238	77,8	33,3	M20	UC215	PH215	-
UCPH216	80	170	292	232	125	25	28	30	253	82,6	33,3	M20	UC216	PH216	-

Note: 1. UC201-->203 hano lo stesso Ø esterno dell' UC204.

UCFA 2

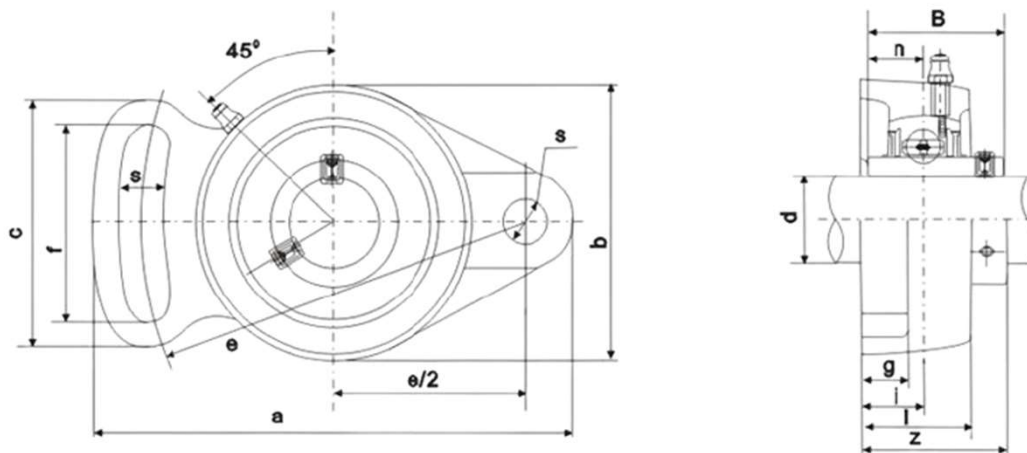

Unità	Dimensioni mm													Vite	Cuscinetto	Housing No.	Peso (kg)
	d	a	e	i	g	l	S	b	Z	f	c	B	n				
UCFA201	12	98	78	15	12	25,5	10	60	33,3	40	50	31	12,7	M8	UC201	FA204	0,50
UCFA202	15	98	78	15	12	25,5	10	60	33,3	40	50	31	12,7	M8	UC202	FA204	0,49
UCFA203	17	98	78	15	12	25,5	10	60	33,3	40	50	31	12,7	M8	UC203	FA204	0,48
UCFA204	20	98	78	15	12	25,5	10	60	33,3	40	50	31	12,7	M8	UC204	FA204	0,46
UCFA205	25	124	98	16	14	27	13	70	35,8	51	65	34,1	14,3	M10	UC205	FA205	0,66
UCFA206	30	141	115	18	14	31	13	83	40,2	58	72	38,1	15,9	M10	UC206	FA206	0,93
UCFA207	35	155	128	19	16	34	15	96	44,4	66	82	42,9	17,5	M12	UC207	FA207	1,46
UCFA208	40	171	142	21	16	38	15	105	51,2	71	87	49,2	19	M12	UC208	FA208	1,78
UCFA209	45	179	146	22	18	40	17	111	52,2	72	90	49,2	19	M14	UC209	FA209	2,03
UCFA210	50	189	155	22	18	40	17	116	54,6	76	94	51,6	19	M14	UC210	FA210	2,23
UCFA211	55	216	182	25	20	44	17	133	58,4	86	104	55,6	22,2	M14	UC211	FA211	-
UCFA212	60	240	202	29	20	48	19	140	68,7	100	118	65,1	25,4	M16	UC212	FA212	-
UCFA213	65	250	210	30	20	50	19	155	69,7	102	122	65,1	25,4	M16	UC213	FB213	-

Note:

- UC201 -> 203 hanno lo stesso Ø esterno dell' UC204.

UCFB 2

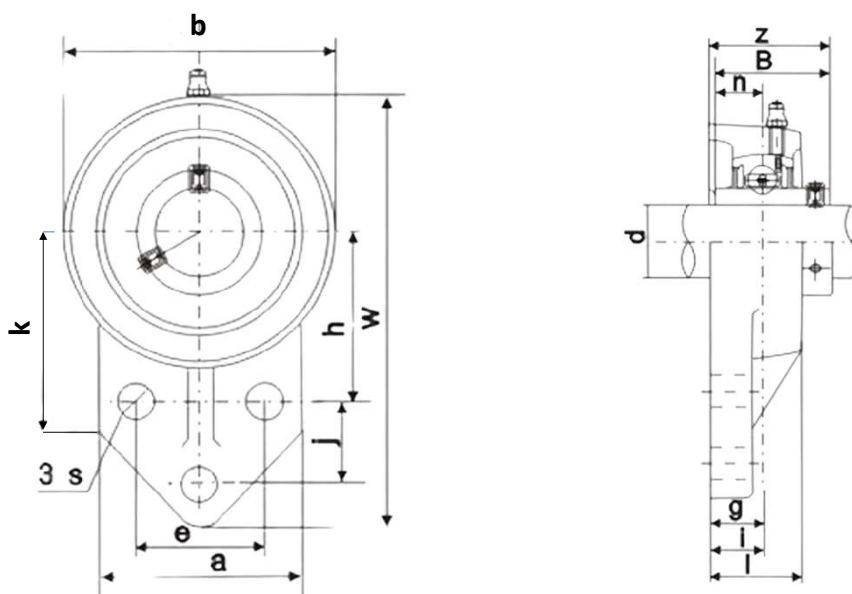

Unità	Dimensioni mm															Vite	Cuscinetto	Housing	Peso (kg)
	d	w	b	k	a	l	s	g	h	J	e	i	z	B	n				
UCFB201	12	110	62	52	52	25,5	10	13	42	27	32	15	33,3	31	12,7	M8	UC201	FB204	0,58
UCFB202	15	110	62	52	52	25,5	10	13	42	27	32	15	33,3	31	12,7	M8	UC202	FB204	0,57
UCFB203	17	110	62	52	52	25,5	10	13	42	27	32	15	33,3	31	12,7	M8	UC203	FB204	0,56
UCFB204	20	110	62	52	52	25,5	10	13	42	27	32	15	33,3	31	12,7	M8	UC204	FB204	0,54
UCFB205	25	116	68	52	56	27	10	13	45	27	34	16	35,8	34,1	14,3	M8	UC205	FB205	0,79
UCFB206	30	130	78	55	65	31	10	13	50	29	40	18	40,2	38,1	15,9	M8	UC206	FB206	0,95
UCFB207	35	144	90	62	70	34	10	15	55	32	46	19	44,4	42,9	17,5	M8	UC207	FB207	1,29
UCFB208	40	164	100	72	78	36	12	16	60	41	50	21	51,2	49,2	19	M10	UC208	FB208	1,78
UCFB209	45	174	106	76	80	38	12	18	65	43	54	22	52,2	49,2	19	M10	UC209	FB209	1,91
UCFB210	50	184	112	82	86	40	12	18	68	46	58	22	54,6	51,6	19	M10	UC210	FB210	2,36
UCFB211	55	207	130	86	90	43	14	18	78	50	62	25	58,4	55,6	22,2	M12	UC211	FB211	3,15
UCFB212	60	223	140	90	94	48	14	18	84	55	66	29	68,7	65,1	25,4	M12	UC212	FB212	3,99
UCFB213	65	244	155	94	100	50	14	20	92	60	70	30	69,7	65,1	25,4	M12	UC213	FB213	-

Note: 1. UC201→203 hanno lo stesso Ø esterno dell' UC204.

UCHA 200

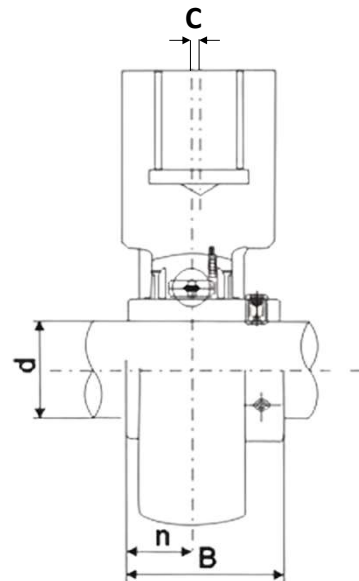
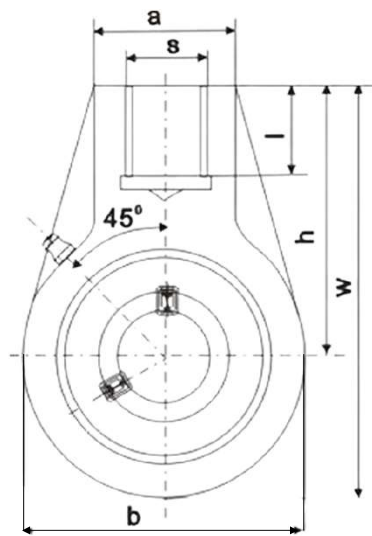

Unità	Dimensioni mm										Cuscinetto	Housing	Peso (kg)
	d	h	w	b	c	a	s	l	B	n			
UCHA201	12	64	96	64	0	40	G3/4	19	31	12,7	UC201	HA204	0,73
UCHA202	15	64	96	64	0	40	G3/4	19	31	12,7	UC202	HA204	0,72
UCHA203	17	64	96	64	0	40	G3/4	19	31	12,7	UC203	HA204	0,71
UCHA204	20	64	96	64	0	40	G3/4	19	31	12,7	UC204	HA204	0,69
UCHA205	25	64	103	78	0	40	G3/4	19	34,1	14,3	UC205	HA205	0,83
UCHA206	30	64	103	78	0	40	G3/4	19	38,1	15,9	UC206	HA206	0,90
UCHA207	35	70	116	92	0	40	G3/4	19	42,9	17,5	UC207	HA207	1,16
UCHA208	40	73	121	96	2	40	G3/4	19	49,2	19	UC208	HA208	1,32
UCHA209	45	82	136	108	5	48	G1	21	49,2	19	UC209	HA209	1,92
UCHA210	50	83	142	118	5	48	G1	21	51,6	19	UC210	HA210	1,90
UCHA211	55	87	150	126	7	60	G1-1/4	25	55,6	22,2	UC211	HA211	2,61
UCHA212	60	102	173	142	9	60	G1-1/4	28	65,1	25,4	UC212	HA212	3,54
UCHA213	65	117	200	166	9,5	70	G1-1/4	32	65,1	25,4	UC213	HA213	5,80

Note: 1. UC201→203 hanno lo stesso Ø esterno dell' UC204.

Supporti lamierino

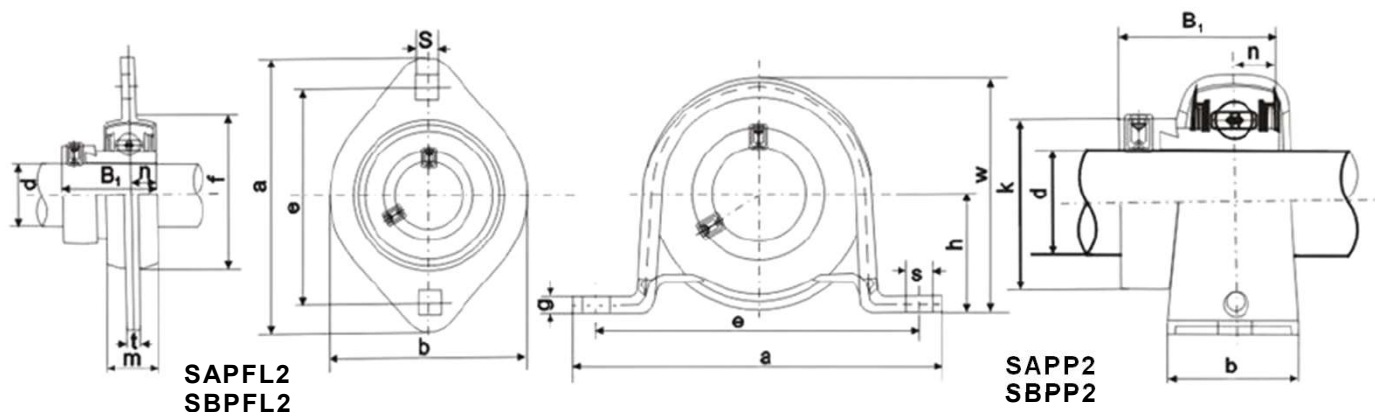

Unità	Dimensioni mm									Vite	SAPF2				SBPF2				Housing
	d	a	e	b	m	S	t	f (min)	B1		n	Cuscinetto	Peso (kg)	B	n	Cuscinetto	Peso (kg)		
SAPFL SBPFL	201	12	81	63,5	59	14	7,1	4	49	M6	28,6	6,5	SA201	0,22	22	6	SB201	0,19	PFL203
SAPFL SBPFL	202	15	81	63,5	59	14	7,1	4	49	M6	28,6	6,5	SA202	0,22	22	6	SB202	0,19	PFL203
SAPFL SBPFL	203	17	81	63,5	59	14	7,1	4	49	M6	28,6	6,5	SA203	0,22	22	6	SB203	0,19	PFL203
SAPFL SBPFL	204	20	90	71,5	67	16	9	4	56	M8	31	7,5	SA204	0,24	25	7	SB204	0,24	PFL204
SAPFL SBPFL	205	25	95	76	71	18	9	4	60	M8	31	7,5	SA205	0,32	27	7,5	SB205	0,28	PFL205
SAPFL SBPFL	206	30	113	90,5	84	18	11	5,2	71	M10	35,7	9	SA206	0,41	30	8	SB206	0,38	PFL206
SAPFL SBPFL	207	35	122	100	94	20	11	5,2	81	M10	38,9	9,5	SA207	0,52	32	8,5	SB207	0,5	PFL207
SAPFL SBPFL	208	40	148	119	100	21	13,5	6,8	91	M12	43,7	11	SA208	0,83	34	9	SB208	0,8	PFL208

Unità	Dimensioni mm									Vite	SAPF2				SBPF2				Housing
	d	h	a	e	b	S	g	w	B1		n	Cuscinetto	Peso (kg)	B	n	Cuscinetto	Peso (kg)		
SAPP SBPP	201	12	22,2	86	68	25	9,5	3,2	43,8	M8	28,6	6,5	SA201	0,19	22	6	SB201	0,16	PP203
SAPP SBPP	202	15	22,2	86	68	25	9,5	3,2	43,8	M8	28,6	6,5	SA202	0,19	22	6	SB202	0,16	PP203
SAPP SBPP	203	17	22,2	86	68	25	9,5	3,2	43,8	M8	28,6	6,5	SA203	0,19	22	6	SB203	0,16	PP203
SAPP SBPP	204	20	25,4	98	76	32	9,5	3,2	50,5	M8	31	7,5	SA204	0,23	25	7	SB204	0,23	PP204
SAPP SBPP	205	25	28,6	108	86	32	11,5	4	56,6	M10	31	7,5	SA205	0,32	27	7,5	SB205	0,28	PP205
SAPP SBPP	206	30	33,3	117	95	38	11,5	4	66,3	M10	35,7	9	SA206	0,5	30	8	SB206	0,47	PP206
SAPP SBPP	207	35	39,7	129	106	42	11,5	4,6	78	M10	38,9	9,5	SA207	0,71	32	8,5	SB207	0,57	PP207

Supporti lamierino

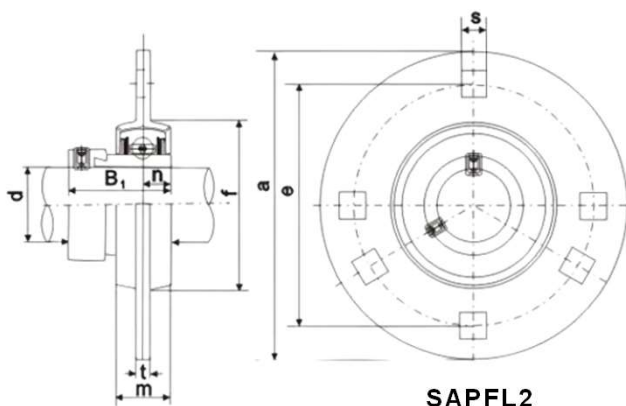

**SAPFL2
SBPFL2**

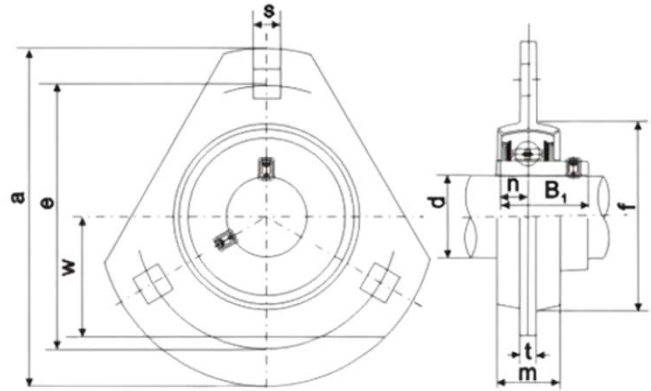

**SAPFT2
SBPFT2**

Unità	Dimensioni mm								Vite	SAPF2				SBPF2				Housing
	d	a	e	m	s	t	f (min)	B1		n	Cuscinetto	Peso (kg)	B	n	Cuscinetto	Peso (kg)		
SAPFL SBPFL	201	12	81	63,5	14	7,1	4	49	M6	28,6	6,5	SA201	0,3	22	6	SB201	0,27	PF203
SAPFL SBPFL	202	15	81	63,5	14	7,1	4	49	M6	28,6	6,5	SA202	0,3	22	6	SB202	0,27	PF203
SAPFL SBPFL	203	17	81	63,5	14	7,1	4	49	M6	28,6	6,5	SA203	0,3	22	6	SB203	0,27	PF203
SAPFL SBPFL	204	20	90	71,5	16	9	4	56	M8	31	7,5	SA204	0,33	25	7	SB204	0,33	PF204
SAPFL SBPFL	205	25	95	76	18	9	4	60	M8	31	7,5	SA205	0,42	27	7,5	SB205	0,38	PF205
SAPFL SBPFL	206	30	113	90,5	18	11	5,2	71	M10	35,7	9	SA206	0,65	30	8	SB206	0,62	PF206
SAPFL SBPFL	207	35	122	100	20	11	5,2	81	M10	38,9	9,5	SA207	0,9	32	8,5	SB207	0,82	PF207
SAPFL SBPFL	208	40	148	119	21	13,5	6,8	91	M12	43,7	11	SA208	1,15	34	9	SB208	1,1	PF208

Unità	Dimensioni mm									Vite	SAPF2				SBPF2				Housing
	d	a	e	w	m	s	t	f (min)	B1		n	Cuscinetto	Peso (kg)	B	n	Cuscinetto	Peso (kg)		
SAPP SBPP	201	12	81	63,5	28,5	14	7,1	4	49	M6	28,6	6,5	SA201	0,26	22	6	SB201	0,23	PFT203
SAPP SBPP	202	15	81	63,5	28,5	14	7,1	4	49	M6	28,6	6,5	SA202	0,26	22	6	SB202	0,23	PFT203
SAPP SBPP	203	17	81	63,5	28,5	14	7,1	4	49	M6	28,6	6,5	SA203	0,26	22	6	SB203	0,23	PFT203
SAPP SBPP	204	20	90	71,5	33	16	9	4	56	M8	31	7,5	SA204	0,28	25	7	SB204	0,28	PFT204
SAPP SBPP	205	25	95	76	35	18	9	4	60	M8	31	7,5	SA205	0,36	27	7,5	SB205	0,36	PFT205
SAPP SBPP	206	30	113	90,5	40	18	11	5,2	71	M10	35,7	9	SA206	0,58	30	8	SB206	0,55	PFT206
SAPP SBPP	207	35	122	100	44,5	20	11	5,2	81	M10	38,9	9,5	SA207	0,82	32	8,5	SB207	0,74	PFT207

P W R

Power & Technology



Via Torino 77/1 – 10040 DRUENTO (TO)

Tel. 011-19775.115



E-mail : info@sidarma.it



www.sidarma.it